

****PLEASE NOTE LOCATION CHANGE****

**ADDENDUM
TO
AGENDA**

CITY COUNCIL MEETING

MONDAY, OCTOBER 2, 2017

7:00 p.m.

*GERALDINE W. JOHNSON SCHOOL - AUDITORIUM
475 LEXINGTON AVENUE
BRIDGEPORT, CONNECTICUT 06604

ADDED:

COMMUNICATIONS TO BE REFERRED TO COMMITTEES:

- 151-16** Communication from City Attorney re: Proposed Approval of Appointment Letter for Fire Chief Richard Thode, referred to Contracts Committee.
- 152-16** Communication from Mayor re: Appointment of Jack O. Banta to the Bridgeport Environmental Task Force, referred to Miscellaneous Matters Committee.
- 153-16** Communication from Mayor re: Appointment of Kathleen Donovan to the Bridgeport Environmental Task Force, referred to Miscellaneous Matters Committee.
- 154-16** Communication from Mayor re: Appointment of Sharon Lewis to the Bridgeport Environmental Task Force, referred to Miscellaneous Matters Committee.
- 155-16** Communication from Mayor re: Appointment of Alma Maya to the Bridgeport Environmental Task Force, referred to Miscellaneous Matters Committee.
- 156-16** Communication from Mayor re: Appointment of Josh Parrow to the Bridgeport Environmental Task Force, referred to Miscellaneous Matters Committee.
- 157-16** Communication from Mayor re: Appointment of Nicholas Roussas to the Bridgeport Environmental Task Force, referred to Miscellaneous Matters Committee.

****PLEASE NOTE LOCATION CHANGE****

AGENDA

CITY COUNCIL MEETING

MONDAY, OCTOBER 2, 2017

7:00 P.M.

****GERALDINE W. JOHNSON SCHOOL - AUDITORIUM** – 475 LEXINGTON AVENUE
BRIDGEPORT, CONNECTICUT 06604**

Prayer

Pledge of Allegiance

Roll Call

Mayoral and City Council Citation(s): Recognizing Mark Marko for his Service on the City's Parks Commission and Exceptional Leadership as its Chairman.

Mayoral and City Council Citation(s): Recognizing "Bridgeport Unidos Por El Mundo" for assisting with the Hurricane Harvey and Puerto Rico Relief Efforts by collecting supplies, donations and shipping them out.

MINUTES FOR APPROVAL:

Approval of City Council Minutes: September 5, 2017

COMMUNICATIONS TO BE REFERRED TO COMMITTEES:

- 145-16** Communication from City Clerk re: Items Pending before City Council Committees Pursuant to City Council Rules Ch. XIII (11), **ACCEPTED AND MADE PART OF THE RECORD.**
- 146-16** Communication from WPCA re: Proposed Amendment to the Municipal Code of Ordinances, Chapter 13.04 – Utilities, Article II. – Water Pollution Control Authority, amend to add New Subsection B to Section 13.04.330 – Allowance for metered water not discharged into the city's sanitary sewer system, referred to Ordinance Committee.
- 148-16** Communication from Central Grants re: Grant Submission: CIRCA Municipal Resilience Grant Program for the Bridgeport Resiliency Project (#18208), referred to Economic and Community Development and Environment Committee.
- 149-16** Communication from Central Grants re: Grant Submission: CIRCA Municipal Resilience Grant Program for the Mirror Lake Coastal Wetland Restoration (#18224), referred to Economic and Community Development and Environment Committee.
- 150-16** Communication from City Attorney re: Proposed Licensing Agreement with the University of Bridgeport for the Use and Improvement of the Baseball Field, Diamond #1 located at Seaside Park, referred to Contracts Committee.

RESOLUTIONS TO BE REFERRED TO BOARDS, COMMISSIONS, ETC.:

- 147-16** Resolution presented by Council Member McBride-Lee re: Request that the Honorary Street Naming of "Reverend William Barber Sr. Way" be designated with appropriate signage to be placed at a portion of Platt Street from Chopsey Hill Road to Ryon Street, referred to Public Safety and Transportation Committee.

MATTERS TO BE ACTED UPON (CONSENT CALENDAR):

- *71-16** Ordinance Committee Report re: Amendments to the Municipal Code of Ordinances, Chapter 2.02 – Administrative Regulations Generally, amend to add new Section 2.02.080 – Residency Reporting of all Municipal Elected Officials and Board and Commission Members.
- *128-16** Ordinance Committee Report re: Amendments to the Municipal Code of Ordinances, Title 3 – Revenue and Finance, Chapter 3.70 – Event Admissions Surcharge, amend to add New Section 3.70.015 – Exemption.
- *131-16** Ordinance Committee Report re: Amendments to the Municipal Code of Ordinances, Title 8 – Health and Safety, amend Chapter 8.88 – Municipal Clinics.
- *100-16** Economic and Community Development and Environment Committee Report re: Disposition of eleven (11) City-Owned Properties within the Seaview Avenue Industrial Park.
- *110-16** Miscellaneous Matters Committee Report re: Settlement of Pending Litigation with Constance L. Taaffe.
- *113-16** Miscellaneous Matters Committee Report re: Refund of Excess Payments – 1700 SPE CT Park LLC.
- *114-16** Miscellaneous Matters Committee Report re: Refund of Excess Payments – Donna Siciliano.
- *138-16** Miscellaneous Matters Committee Report re: Settlement of Pending Litigation with Kyle J. Hampton.
- *139-16** Miscellaneous Matters Committee Report re: Settlement of Pending Litigation with Carlens and Evens Dorvelus.

THE FOLLOWING NAMED PERSON HAS REQUESTED PERMISSION TO ADDRESS THE CITY COUNCIL ON MONDAY, OCTOBER 2, 2017 AT 6:30 P.M., AT GERALDINE W. JOHNSON SCHOOL, AUDITORIUM, 475 LEXINGTON AVENUE, BRIDGEPORT, CT 06604.

NAME

SUBJECT

John Marshall Lee
30 Beacon Street
Bridgeport, CT 06605

Financial Status of City.

Cecil C. Young
99 Carroll Avenue
Bridgeport, CT 06607

Unjust termination cover-up.

****PLEASE NOTE LOCATION CHANGE****

**CITY COUNCIL MEETING
PUBLIC SPEAKING
MONDAY, OCTOBER 2, 2017
6:30 PM**

**Geraldine W. Johnson School, Auditorium
475 Lexington Avenue
Bridgeport, CT 06604**

CALL TO ORDER

Council President McCarthy called the Public Speaking session to order at 6:48 p.m.

ROLL CALL

The Lydia Martinez, City Clerk called the roll.

130th District: Kathryn Bukovsky, Scott Burns
131st District: Jack O. Banta, Denese Taylor-Moye
132nd District: M. Evette Brantley, John Olson
133rd District: Thomas McCarthy, Jeanette Herron
134th District: Michelle Lyons
135th District: Mary McBride-Lee, Richard Salter
136th District: José Casco, Alfredo Castillo
137th District: Aidee Nieves, Milta Feliciano
138th District: Anthony Paoletto
139th District: Eneida Martinez, James Holloway

RECEIVED
CITY CLERKS OFFICE
17 OCT 10 PM 1:51
ATTEST
CITY CLERK

A quorum was present.

THE FOLLOWING NAMED PERSON HAS REQUESTED PERMISSION TO ADDRESS THE CITY COUNCIL ON MONDAY, OCTOBER 2, 2017 AT 6:30 P.M., AT GERALDINE W. JOHNSON SCHOOL, AUDITORIUM, 475 LEXINGTON AVENUE, BRIDGEPORT, CT 06604.

NAME

SUBJECT

John Marshall Lee
30 Beacon Street
Bridgeport, CT 06605

Financial Status of City.

United, blessed, privileged, fearful, white and for too much of history, ignorant:

God Bless America... bountiful and beautiful.....sweet land of liberty...freedom... to assemble, speak and practice religion.....and equal rights (initially white, literate men with property).....and

second chances for those from other lands who would work in the growing capitalist enterprise and hope for chances for an educated second generation?

Perhaps we know our family story and how and when it intersects those of other people with white skin particularly those from Western Europe. But do we know or have we reflected on those others who were initially present when the first Europeans landed and how the settlers dealt with those of color who were present? And the land was so fertile and large that more workers were required to make the land fruitful, especially in the Southern colonies (and States) so Africans captured were brought to the coasts for sale in chains, suffered the Middle Passage across the Atlantic, and about 8% of the 6 Million enslaved blacks were landed in the colonies/US before importation was made illegal in 1807, though slavery continued. By 1861 the number of blacks in the US had grown to about 4 Million people and perhaps 10% served in Northern or Southern armies during the Civil War with about 60,000 casualties.

After the Emancipation Proclamation 1863 and end of Civil War, 1865 plantations whose real wealth were humans indentured and controlled for life. So relations had to change to keep cotton, tobacco, rice, sugar cane crops flowing and segregation, Jim Crow and other measures to keep African Americans in an inferior place became common in the South, and in the North through limited education, housing, and workplace opportunities. Inferiority of blacks became a self-fulfilling eventuality over generations. But notable and exceptional people caused questions to rise among those who used their heart, minds, body and spirits to live life and grow in wisdom as Christians.

Country of opportunity for all....if fair chances and basic lessons are available to all. And God provided talent gifts of certain kinds may appear in athletic, musical, ingenuity, and comedic format, though talent at humor and comedy may be the gift to those who have lived with the absurd too long. Will privilege, if understood as a matter of chance, something unearned, when referenced and put in a rightful place, allow all people to identify how much our privilege has contributed to results in the journey so far, and how much is owed to that which is a gift at birth? Knowing the story of your family and listening to that of others will lead to connections of universal experiences by humans that transcend skin color. Now how do we address this gift or privilege in living out our years? Do we call upon the Spirit daily in prayer for grace and wisdom? Time will tell.

John Marshall Lee 10-2-17

Mr. Lee then read the following poem by Langston Hughes into the record:

BALLAD OF THE LANDLORD
By Langston Hughes
Landlord, Landlord,
My roof has sprung a leak.
Don't you 'member I told you about it
Way last week?
Landlord, Landlord,

City of Bridgeport
City Council
Regular Meeting
October 2, 2017

These steps is broken down.
When you come up yourself
It's a wonder you don't fall down.
Ten Bucks you say I owe you?
Ten Bucks you say is due?
Well, that's Ten Bucks more'n I'll pay you
Till you fix this house up new.
What? You gonna get evic'on orders?
You gonna cut off my heat?
You gonna take my furniture and
Throw it in the street?
Um-huh! You talking high and mighty.
Talk on---till you get through.
You ain't gonna be able to say a word
If I land my fist on you.

Police! Police!
Come and get this man!
He's trying to ruin the government
And overturn the land!

Copper's whistle!
Patrol bell!
Arrest.

Precinct Station.
Iron cell.
Headlines in press:
MAN THREATENS LANDLORD

TENANT HELD NO BAIL

JUDGE GIVES NEGRO 90 DAYS IN COUNTY JAIL.
(LANGSTON HUGHES READER, 1957, P. 101)

Cecil C. Young
99 Carroll Avenue
Bridgeport, CT 06607

Unjust termination cover-up.

Council President McCarthy called Mr. Young forward. There was no response. He repeated the call two more times. There was still no response. Council President McCarthy called Mr. Young a fourth and final time with no response.

Charles Coviello

Mr. Coviello said that he watches Channel 12 and they stated that the IRS is the most powerful collection agency in the world. However, Mr. Coviello disagrees with that statement because he believes it is actually Bridgeport WPCA. He then spoke about how he had almost lost his house. When all is said and done, he has paid over \$15,000 and there are still legal fees and interest being added. Mr. Coviello reminded everyone that during the last council session, a Republican Council member submitted a piece of legislation to curb this financial abuse and still nothing has been done. This needs to be addressed by the Council and the WPCA needs to be curbed.

Dasha Spell

Golden Hill Street
Bridgeport, CT 06604

Ms. Spell spoke about a letter she had received from the Mayor about education. She said that she would like to know how the Council members who had gone to school in Bridgeport and received a good education could let today's students receive such a poor education. She asked if they would be reaching out to the youth to prevent the violence. Some key problems that contribute to violence are poor educations, mental health issues and no support.

Ms. Spell said that she wanted everyone to help her help the Bridgeport students. She wants people to be invested. Next Thursday, she will be holding a meeting about this. It will be important to go into the schools and see what is happening. Some of the buildings are leaking and others have mold in them.

Ernest Newton

190 Read Street
Bridgeport, CT 06607

Mr. Newton came forward and said that he hoped that the City Council would pay attention to the agenda item 146-16, which involves the WPCA. He spoke about a resident who lived in Bridgeport for 30 years and then the WPCA foreclosed on his house. Now they are talking about how the WPCA will be putting an outside meter on the houses so that if the people wash their cars, they will have to pay for it. This is something that needs to have the Council pay serious attention to because it will affect the senior citizens. This is just another way to put people out with foreclosures.

ADJOURNMENT

Council President McCarthy adjourned the public speaking portion of the Council meeting at 6:57 p.m.

Respectfully submitted,

S. L. Soltes
Telesco Secretarial Services

City of Bridgeport
City Council
Regular Meeting
October 2, 2017

**CITY OF BRIDGEPORT
CITY COUNCIL MEETING
MONDAY, OCTOBER 2, 2017
7:00 PM**

**Geraldine W. Johnson School, Auditorium
475 Lexington Avenue
Bridgeport, Connecticut 06604**

CALL TO ORDER

Mayor Ganim called the meeting to order at 7:09 p.m.

PRAYER

Mayor Ganim requested Council Member McBride-Lee lead everyone present in prayer, particularly remembering the victims of the Las Vegas shooting on October 1st. He also requested that following the conclusion of the prayer, there be a moment of silence.

Council Member McBride-Lee prayed for the victims of Hurricane Harvey and Maria in Puerto Rico and for the victims of the largest mass shooting in the history of the United States that happened on October 1, 2017 in Las Vegas.

This was followed by a moment of silence in honor of those who were injured or who died.

PLEDGE OF ALLEGIANCE

Mayor Ganim then requested Council Member Olson to lead those present in reciting the Pledge of Allegiance.

ROLL CALL

City Clerk Martinez called the roll.

130th District: Kathryn Bukovsky, Scott Burns
131st District: Jack O. Banta, Denese Taylor-Moye
132nd District: M. Evette Brantley, John Olson
133rd District: Thomas McCarthy, Jeanette Herron
134th District: Michelle Lyons
135th District: Mary McBride-Lee, Richard Salter
136th District: José Casco, Alfredo Castillo
137th District: Aidee Nieves, Milta Feliciano
138th District: Anthony Paoletto, Nessah Smith
139th District: Eneida Martinez, James Holloway

A quorum was present.

Mayoral and City Council Citation(s): Recognizing Mark Marko for his Service on the City's Parks Commission and Exceptional Leadership as its Chairman.

Council President McCarthy called Mr. Marko forward, along with his family and the Parks Department who were present. One thing that Mr. Marko was well known for asking was "Is it good for the kids?" and then finding a way to make events happen.

Mayor Ganim also spoke about how many things Mr. Marko has done for the City of Bridgeport and presented him with a certificate of recognition.

Mayoral and City Council Citation(s): Recognizing "Bridgeport Unidos Por El Mundo" for assisting with the Hurricane Harvey and Puerto Rico Relief Efforts by collecting supplies, donations and shipping them out.

Council Member Feliciano said that the group was not able to attend the meeting because they were still in New Jersey getting the containers.

Council Member Holloway left the meeting at 7:05 p.m.

MINUTES FOR APPROVAL:

Approval of City Council Minutes: September 5, 2017

**** COUNCIL MEMBER PAOLETTO MOVED THE MINUTES OF SEPTEMBER 5, 2017.**

**** COUNCIL PRESIDENT MCCARTHY SECONDED.**

**** THE MOTION TO APPROVE THE MINUTES OF SEPTEMBER 5, 2017 PASSED UNANIMOUSLY.**

COMMUNICATIONS TO BE REFERRED TO COMMITTEES:

**** COUNCIL PRESIDENT MCCARTHY MOVED TO WITHDRAW AGENDA ITEM 152-16 COMMUNICATION FROM MAYOR RE: APPOINTMENT OF JACK O. BANTA TO THE BRIDGEPORT ENVIRONMENTAL TASK FORCE, REFERRED TO MISCELLANEOUS MATTERS COMMITTEE HAD BEEN WITHDRAWN FOR REFERRAL TO THE MISCELLANEOUS MATTERS COMMITTEE.**

**** COUNCIL MEMBER PAOLETTO SECONDED.**

**** THE MOTION PASSED UNANIMOUSLY.**

**** COUNCIL MEMBER BURNS MOVED THE FOLLOWING ITEMS TO BE REFERRED TO COMMITTEE AND RESOLUTIONS TO BE REFERRED TO BOARDS, COMMISSIONS, ETC. :**

145-16 COMMUNICATION FROM CITY CLERK RE: ITEMS PENDING BEFORE CITY COUNCIL COMMITTEES PURSUANT TO CITY COUNCIL RULES CH. XIII (11), ACCEPTED AND MADE PART OF THE RECORD.

146-16 COMMUNICATION FROM WPCA RE: PROPOSED AMENDMENT TO THE MUNICIPAL CODE OF ORDINANCES, CHAPTER 13.04 – UTILITIES, ARTICLE II. – WATER POLLUTION CONTROL AUTHORITY, AMEND TO ADD NEW SUBSECTION B TO SECTION 13.04.330 – ALLOWANCE FOR METERED WATER NOT DISCHARGED INTO THE CITY’S SANITARY SEWER SYSTEM, REFERRED TO ORDINANCE COMMITTEE.

148-16 COMMUNICATION FROM CENTRAL GRANTS RE: GRANT SUBMISSION: CIRCA MUNICIPAL RESILIENCE GRANT PROGRAM FOR THE BRIDGEPORT RESILIENCY PROJECT (#18208), REFERRED TO ECONOMIC AND COMMUNITY DEVELOPMENT AND ENVIRONMENT COMMITTEE.

149-16 COMMUNICATION FROM CENTRAL GRANTS RE: GRANT SUBMISSION: CIRCA MUNICIPAL RESILIENCE GRANT PROGRAM FOR THE MIRROR LAKE COASTAL WETLAND RESTORATION (#18224), REFERRED TO ECONOMIC AND COMMUNITY DEVELOPMENT AND ENVIRONMENT COMMITTEE.

150-16 COMMUNICATION FROM CITY ATTORNEY RE: PROPOSED LICENSING AGREEMENT WITH THE UNIVERSITY OF BRIDGEPORT FOR THE USE AND IMPROVEMENT OF THE BASEBALL FIELD, DIAMOND #1 LOCATED AT SEASIDE PARK, REFERRED TO CONTRACTS COMMITTEE.

151-16 COMMUNICATION FROM CITY ATTORNEY RE: PROPOSED APPROVAL OF APPOINTMENT LETTER FOR FIRE CHIEF RICHARD THODE, REFERRED TO CONTRACTS COMMITTEE.

153-16 COMMUNICATION FROM MAYOR RE: APPOINTMENT OF KATHLEEN DONOVAN TO THE BRIDGEPORT ENVIRONMENTAL TASK FORCE, REFERRED TO MISCELLANEOUS MATTERS COMMITTEE.

154-16 COMMUNICATION FROM MAYOR RE: APPOINTMENT OF SHARON LEWIS TO THE BRIDGEPORT ENVIRONMENTAL TASK FORCE, REFERRED TO MISCELLANEOUS MATTERS COMMITTEE.

155-16 COMMUNICATION FROM MAYOR RE: APPOINTMENT OF ALMA MAYA TO THE BRIDGEPORT ENVIRONMENTAL TASK FORCE, REFERRED TO MISCELLANEOUS MATTERS COMMITTEE.

156-16 COMMUNICATION FROM MAYOR RE: APPOINTMENT OF JOSH PARROW TO THE BRIDGEPORT ENVIRONMENTAL TASK FORCE, REFERRED TO MISCELLANEOUS MATTERS COMMITTEE.

157-16 COMMUNICATION FROM MAYOR RE: APPOINTMENT OF NICHOLAS ROUSSAS TO THE BRIDGEPORT ENVIRONMENTAL TASK FORCE, REFERRED TO MISCELLANEOUS MATTERS COMMITTEE.

**RESOLUTIONS TO BE REFERRED TO BOARDS,
COMMISSIONS, ETC.:**

147-16 RESOLUTION PRESENTED BY COUNCIL MEMBER MCBRIDE-LEE RE: REQUEST THAT THE HONORARY STREET NAMING OF “REVEREND WILLIAM BARBER SR. WAY” BE DESIGNATED WITH APPROPRIATE SIGNAGE TO BE PLACED AT A PORTION OF PLATT STREET FROM CHOPSEY HILL ROAD TO RYON STREET, REFERRED TO PUBLIC SAFETY AND TRANSPORTATION COMMITTEE.

- ** COUNCIL PRESIDENT MCCARTHY SECONDED.**
- ** THE MOTION PASSED UNANIMOUSLY.**

MATTERS TO BE ACTED UPON (CONSENT CALENDAR):

- *71-16 Ordinance Committee Report re: Amendments to the Municipal Code of Ordinances, Chapter 2.02 – Administrative Regulations Generally, amend to add new Section 2.02.080 – Residency Reporting of all Municipal Elected Officials and Board and Commission Members.**
- *128-16 Ordinance Committee Report re: Amendments to the Municipal Code of Ordinances, Title 3 – Revenue and Finance, Chapter 3.70 – Event Admissions Surcharge, amend to add New Section 3.70.015 – Exemption.**
- *131-16 Ordinance Committee Report re: Amendments to the Municipal Code of Ordinances, Title 8 – Health and Safety, amend Chapter 8.88 – Municipal Clinics.**
- *100-16 Economic and Community Development and Environment Committee Report re: Disposition of eleven (11) City-Owned Properties within the Seaview Avenue Industrial Park.**
- *110-16 Miscellaneous Matters Committee Report re: Settlement of Pending Litigation with Constance L. Taaffe.**
- *113-16 Miscellaneous Matters Committee Report re: Refund of Excess Payments – 1700 SPE CT Park LLC.**
- *114-16 Miscellaneous Matters Committee Report re: Refund of Excess Payments – Donna Siciliano.**
- *138-16 Miscellaneous Matters Committee Report re: Settlement of Pending Litigation with Kyle J. Hampton.**
- *139-16 Miscellaneous Matters Committee Report re: Settlement of Pending Litigation with Carlens and Evens Dorvelus.**

Mayor Ganim asked if there was any Council Member who would like to remove an item from the Consent Calendar. Council Member

Mayor Ganim requested that the City Clerk read the remaining Consent Calendar items into the record. Council Member Martinez requested that Agenda Item 71-16 be removed from the Consent Calendar. Council Member Bukovsky requested that Agenda Item 128-16 be removed from the Consent Calendar.

Mayor Ganim requested that the City Clerk read the remaining Consent Calendar items into the record.

**** COUNCIL MEMBER MARTINEZ MOVED THE FOLLOWING ITEMS AS THE CONSENT CALENDAR:**

***131-16 ORDINANCE COMMITTEE REPORT RE: AMENDMENTS TO THE MUNICIPAL CODE OF ORDINANCES, TITLE 8 – HEALTH AND SAFETY, AMEND CHAPTER 8.88 – MUNICIPAL CLINICS.**

***100-16 ECONOMIC AND COMMUNITY DEVELOPMENT AND ENVIRONMENT COMMITTEE REPORT RE: DISPOSITION OF ELEVEN (11) CITY-OWNED PROPERTIES WITHIN THE SEAVIEW AVENUE INDUSTRIAL PARK.**

***110-16 MISCELLANEOUS MATTERS COMMITTEE REPORT RE: SETTLEMENT OF PENDING LITIGATION WITH CONSTANCE L. TAAFFE.**

***113-16 MISCELLANEOUS MATTERS COMMITTEE REPORT RE: REFUND OF EXCESS PAYMENTS – 1700 SPE CT PARK LLC.**

***114-16 MISCELLANEOUS MATTERS COMMITTEE REPORT RE: REFUND OF EXCESS PAYMENTS – DONNA SICILIANO.**

***138-16 MISCELLANEOUS MATTERS COMMITTEE REPORT RE: SETTLEMENT OF PENDING LITIGATION WITH KYLE J. HAMPTON.**

***139-16 MISCELLANEOUS MATTERS COMMITTEE REPORT RE: SETTLEMENT OF PENDING LITIGATION WITH CARLENS AND EVENS DORVELUS.**

**** COUNCIL PRESIDENT MCCARTHY SECONDED.**

**** THE MOTION PASSED UNANIMOUSLY.**

***128-16 Ordinance Committee Report re: Amendments to the Municipal Code of Ordinances, Title 3 – Revenue and Finance, Chapter 3.70 – Event Admissions Surcharge, amend to add New Section 3.70.015 – Exemption.**

**** COUNCIL MEMBER BUKOVSKY MOVED TO REFER AGENDA ITEM 128-16 BACK TO COMMITTEE.**

**** COUNCIL MEMBER SALTER SECONDED.**

**** THE MOTION PASSED UNANIMOUSLY.**

***71-16 Ordinance Committee Report re: Amendments to the Municipal Code of Ordinances, Chapter 2.02 – Administrative Regulations Generally, amend to add new Section 2.02.080 – Residency Reporting of all Municipal Elected Officials and Board and Commission Members.**

**** COUNCIL MEMBER MARTINEZ MOVED TO REFER AGENDA ITEM 71-16 BACK TO COMMITTEE.**

**** COUNCIL MEMBER FELICIANO SECONDED.**

**** THE MOTION PASSED WITH FIFTEEN (15) IN FAVOR (BURNS, BANTA, TAYLOR-MOYE, BRANTLEY, MCCARTHY, HERRON, MCBRIDE-LEE, SALTER, CASCO, CASTILLO, NIEVES, FELICIANO, PAOLETTO, SMITH, AND MARTINEZ) AND THREE OPPOSED (BUKOVSKY, LYONS AND OLSON).**

**** COUNCIL MEMBER LYONS MOVED TO SUSPEND THE RULES TO ADD AN ITEM TO THE AGENDA REGARDING A REFERRAL TO THE ORDINANCE COMMITTEE.**

**** COUNCIL PRESIDENT MCCARTHY SECONDED.**

**** THE MOTION PASSED UNANIMOUSLY.**

**** COUNCIL MEMBER LYONS MOVED TO REFER AGENDA ITEM TO THE ORDINANCE COMMITTEE REGARDING PROPOSED ORDINANCE CONCERNING HOLDING LANDLORDS ACCOUNTABLE FOR TENANT GENERATED NOISE RESULTING IN COMPLAINTS FILED/WARNING PROCESS AND FINES FOR REPEATED VIOLATIONS.**

**** COUNCIL MEMBER FELICIANO SECONDED.**

**** THE MOTION PASSED UNANIMOUSLY. (ITEM #158-16)**

Council Member Olson commented that he agreed with Mike Dailey's recent column regarding the casinos.

Council Member Martinez said that she was dismayed that the BOE would cut teachers, aides or student services before it would reduce administrator's salaries or positions.

Regarding the City Attorney's Office, she added that she was disappointed that there were two items presented without legal opinions.

Council Member Martinez said that she was also disappointed to see an off-duty detective directing traffic at a recent event before the traffic officers arrived to perform their job.

Council Member McBride-Lee said that she agreed with those who had spoken about the WPCA issues and said that it was wrong for the WPCA to charge people for watering their grass. The WPCA should be fired.

ADJOURNMENT

- ** COUNCIL MEMBER PAOLETTO MOVED TO ADJOURN.**
- ** COUNCIL MEMBER FELICIANO SECONDED.**
- ** THE MOTION PASSED UNANIMOUSLY.**

The meeting adjourned 7:41 p.m.

Respectfully submitted,

S. L. Soltes
Telesco Secretarial Service



City of Bridgeport, Connecticut

OFFICE OF THE CITY CLERK

LEGISLATIVE DEPARTMENT

45 Lyon Terrace • Bridgeport, Connecticut 06604 • Telephone (203) 576-7081 • Fax (203) 332-5608

LYDIA N. MARTINEZ
City Clerk

FRANCES ORTIZ
Assistant City Clerk

COMM. 145-16 Accepted and Made Part of the Record (10-2-17)

September 26, 2017

Honorable City Council Members
City of Bridgeport, Connecticut

Dear Council Members:

Pursuant to City Council Rules Chapter XIII, Subsection 11, attached is a report of all items pending before the City Council Committees.

Please be reminded that any item not acted upon at the final council session to be held on November 6, 2017 will be filed as sine die, and will require resubmission for December if action is still required.

Respectfully submitted,

Lydia N. Martinez
City Clerk

**BUDGET AND APPROPRIATIONS COMMITTEE
PENDING ITEMS
AS OF OCTOBER 2, 2017**

Number	Type	Summary	Submitted by:	Date Referred:
		General discussion regarding the review of the Monthly Financial Report.		
		Budget Update from City Department:		
147-15	Comm.	Proposed Budget Transfer to Fiscal Year 2016-2017 General Fund Budget to Accommodate the FY 2016-2017 Second Chance Initiative Program From: Public Facilities Maintenance (Property Insurance) Account #01310000-53435 (\$40,000) and P.F. Roadway (Public Facilities Services) Account #01320000-56185 (\$10,000) To: Police Department "Other Services" Account #01250000-56180 (\$50,000).	Nestor Nkwo, OPM Director	06/20/2016, Comm. <u>Tabled</u> and Amended by Substitution on: 07/11/2016, Comm. <u>Tabled</u> on: 09/12/2016

**CONTRACTS COMMITTEE
PENDING ITEMS
AS OF OCTOBER 2, 2017
PAGE 1 of 1**

Number	Type	Summary	Submitted by:	Date
90-16	Res.	Proposed Resolution to Terminate the Contract with LAZ Parking LTD., LLC.	Councilmember(s): Jack Banta, Denese Taylor-Moye, D-131 st ; Scott Burns, Milta Feliciano, Jeanette Herron, John Olson, Jose Casco, M. Evette Brantley, James Holloway, Aidee Nieves & Michelle Lyons	06/19/2017 , Ref'd to City Atty's Office on: 06/20/2017 , Tabled by Committee on: 07/11/2017, 08/21/2017
91-16	Res.	Proposed Resolution for a 12-Month Moratorium on Parking Meter Collections & Enforcement.	Councilmember(s): Jack Banta, Denese Taylor-Moye, D-131 st ; Scott Burns, Milta Feliciano, Jeanette Herron, John Olson, Jose Casco, M. Evette Brantley, James Holloway, Aidee Nieves & Michelle Lyons	06/19/2017 , Ref'd to City Atty's Office on: 06/20/2017 , Tabled by Committee on: 07/11/2017, 08/21/2017

**ECONOMIC & COMMUNITY DEVELOPMENT & ENVIRONMENT
COMMITTEE
PENDING ITEMS
As of
October 2, 2017**

Number	Type	Summary	Submitted by:	Date
119-16	Comm.	Grant Submission: re State of Connecticut Department of Education – Youth Services Bureau. (#18532)	Isolina DeJesus, Director, Central Grants Office	Referred to Committee on 08/07/2017 Tabled on 8/22/2017
121-16	Comm.	Grant Submission: State of Connecticut Department of Education – Youth Services Bureau Enhancement. (#18540)	Isolina DeJesus, Director, Central Grants Office	Referred to Committee on 08/07/2017 Tabled by Committee on 8/22/2017
127-16	Comm.	Proposed Resolution authorizing the Disposition of Certain City-Owned Properties (5) by Auction, Sale to Abutter or by Sale to Community Based Housing Development Corporations and Ordering a Public Hearing Relative to the Same.	Max Perez, Director, Business Development	Referred to Committee on 09/05/2017
132-16	Comm.	Grant Submission: re U. S. Conference of Mayors for FY2018 Childhood Obesity Prevention Awards. (#18305)	Isolina Dejesus, Director, Central Grants Office	Referred to Committee on 09/05/2017
133-16	Comm.	Grant Submission: re State of Connecticut Department of Public Health Emergency Preparedness Grant. (#18221)	Isolina Dejesus, Director, Central Grants Office	Referred to Committee on 09/05/2017

**EDUCATION & SOCIAL SERVICES
COMMITTEE
PENDING ITEMS
As of October 2, 2017**

Number	Type	Summary	Submitted by	Date
		No Pending Items in Committee		

MISCELLANEOUS MATTERS COMMITTEE
PENDING ITEMS
As of
October 2, 2017

Number	Type	Summary	Submitted by	Date
07-15	Comm.	Proposed approval of a new job classification with NAGE Local RI-200 of Senior Housing Code Inspector/Enforcement Officer.	David Dunn, Personnel Director, Civil Service	Referred to Committee on 12/7/2015 Tabled by Committee on 1/2/2016 (Special Meeting) Tabled by Committee 1/25/16 Tabled by Committee 2/22 Tabled by Committee on 3/28/16
225-15	Comm.	Appointment of Aaron R. Turner (D) to the Commission on Planning & Zoning.	Joseph P. Ganim, Mayor	Referred to Committee on 11/21/2016 Tabled by Committee on 11/28/16 Tabled by Committee on 3/27/17
12-16	Comm.	Proposed Resolution authorizing the establishment of a formal Sister City relationship with the Palestinian city of Bethlehem.	Joseph P. Ganim, Mayor	Referred to Committee on 12/19/2016 (OFF THE FLOOR) Tabled by Committee 1/30/17

**ORDINANCE COMMITTEE
PENDING ITEMS
AS OF OCTOBER 2, 2017, PAGE 1 of 2**

Number	Type	Summary	Submitted by:	Date
68-15	COMM.	Proposed Amendments to the Municipal Code of Ordinances, Chapter 2.38 – Code of Ethics amend Sections: 2.38.020 – Definitions and 2.38.040C – Commission on ethics.	Mark T. Anastasi, Associate City Attorney	<u>02/29/2016 (Special Meeting)</u> Ref'd to City Attorney's Office on: 03/01/2016, Tabled by Committee on: 03/22/2016, 05/24/2016, 10/25/2016, 11/22/2016, 01/24/2017, 02/28/17, 05/23/2017, 06/27/17, 07/25/17, 09/26/17
69-15	COMM.	Proposed Amendment to the Municipal Code of Ordinances, Title 2 Administration and Personnel, amend to add New Chapter 2.125 – Commission and Office of Governmental Accountability.	Mark T. Anastasi, Associate City Attorney	<u>02/29/2016 (Special Meeting)</u> Ref'd to City Attorney's Office on: 03/01/2016, Tabled by Committee on: 03/22/2016, 05/24/2016, 10/25/2016, 11/22/2016, 01/24/2017, 02/28/17, 05/23/2017, 06/27/17, 07/25/17, 09/26/17
94-15	RES.	Proposed Resolution regarding Off-Campus Student Housing in One, Two, and Three Dwelling Unit Buildings.	Councilmember Michelle A. Lyons, D-134th	<u>04/04/2016 (OFF THE FLOOR)</u> Ref'd to City Attorney's Office on: 04/21/2016, Tabled by Committee on: 10/25/2016, 11/22/2016, 01/24/2017, 02/28/17, 05/23/2017, 06/27/17, 07/25/17, 09/26/17
95-15	RES.	Proposed Resolution regarding the Establishing of a Landlord Checklist for Student Housing Permit and a Separate Student Housing Renewal Packet.	Councilmember Michelle A. Lyons, D-134th	<u>04/04/2016 (OFF THE FLOOR)</u> Ref'd to City Attorney's Office on: 04/21/2016, Tabled by Committee on: 10/25/2016, 11/22/2016, 01/24/2017, 02/28/17, 05/23/2017, 06/27/17, 07/25/17, 09/26/17
128-15	COMM.	Proposed Amendments to the Municipal Code of Ordinances, Chapter 2.38 Code of Ethics, amend to add new Section 2.38.050 Provision concerning subsequent employment.	Mark T. Anastasi, Associate City Attorney	<u>05/16/2016 (Off The Floor)</u> , Tabled by Committee on: 05/24/2016, 10/25/2016, 11/22/2016, 01/24/2017, 02/28/17, 05/23/2017, 06/27/17, 07/25/17, 09/26/17

**ORDINANCE COMMITTEE
PENDING ITEMS
AS OF OCTOBER 2, 2017 PAGE 2 of 2**

Number	Type	Summary	Submitted by:	Date
33-16	RES.	Proposed resolution requesting the City Attorney's Office to create an ordinance that requires the WPCA to implement a Customer Mediation Program for Liens and Foreclosures	Councilmember Eneida Martinez, D-139th	<u>02/06/2017</u> Ref'd to City Attorney's Office on: 02/08/2017 , Tabled by Committee on: 05/23/2017, 06/27/17, 07/25/17, 09/26/17
34-16	RES.	Proposed resolution requesting the City Attorney's Office to create an ordinance that requires the Habitat for Humanity to implement a Customer Mediation Program for Liens and Foreclosures	Councilmember Eneida Martinez, D-139th	<u>02/06/2017</u> Ref'd to City Attorney's Office on: 02/08/2017 , Tabled by Committee on: 05/23/2017, 06/27/17, 07/25/17, 09/26/17
61-16	COMM.	Proposed Amendment to the Municipal Code of Ordinances, amend chapter 2.98 – Historic District Commission.	Lynn M Haig, Director of Planning, OPED	<u>04/17/2017</u> Tabled by Committee on: 06/27/2017, 07/25/17, 09/26/17
141-16	COMM.	Proposed Amendments to the Municipal Code of Ordinances, Chapter 3.20 – Tax Incentive Development Program, amend Section 3.20.060(G) – Miscellaneous Provisions.	Bill Coleman, Deputy Director, OPED	<u>09/18/2017</u> Ref'd to City Attorney's Office on: 09/19/2017 , Tabled by Committee on: 09/26/2017
142-16	COMM.	Proposed Amendments to the Municipal Code of Ordinances, Chapter 3.24 – Affordable Housing Tax Incentive Development Program, amend Section 3.24.040(F) – Miscellaneous.	Bill Coleman, Deputy Director, OPED	<u>09/18/2017</u> Ref'd to City Attorney's Office on: 09/19/2017 , Tabled by Committee on: 09/26/2017
143-16	COMM.	Proposed Resolution Approving Uniform Policies, Procedures and Forms per Municipal Code of Ordinance Section 3.20.020(C) – Program Administration.	Bill Coleman, Deputy Director, OPED	<u>09/18/2017</u> Ref'd to City Attorney's Office on: 09/19/2017 , Tabled by Committee on: 09/26/2017
144-16	COMM.	Proposed Resolution Approving Uniform Policies, Procedures and Forms Per Municipal Code of Ordinance Section 3.24.020(C) – Program Administration.	Bill Coleman, Deputy Director, OPED	<u>09/18/2017</u> Ref'd to City Attorney's Office on: 09/19/2017 , Tabled by Committee on: 09/26/2017

**PUBLIC SAFETY & TRANSPORTATION
COMMITTEE
PENDING ITEMS
As of
October 2, 2017**

Number	Type	Summary	Submitted by:	Date
21-16	Res.	Proposed Resolution concerning a Pilot Alleyway Dumping Enforcement and Revitalization Project for the Seeley Street and Iranistan Avenue Alleyway.	Council members Denese Taylor-Moye Jack O. Banta D-131 st	Referred to Council on 1/17/2017 Tabled by Committed on 3/7/2017 Tabled 4/26/2017 Tabled 7/5/2017 Tabled 9/6/2017
30-16	Res.	Proposed Resolution requesting City of Bridgeport residents who have a criminal history be allowed the opportunity to obtain a copy their criminal record at no cost.	Council members Eneida Martinez D-139 th	Referred to Council on 2/6/2017 Tabled by Committed on 3/7/2017 Tabled 4/26/2017 Tabled 7/5/2017 Tabled 9/6/2017
130-16	Res.	Honorary Naming of Lafayette Street between South Frontage Road and Railroad Avenue as Winifred Timberlake Way".	Council members Denese Taylor-Moye Jack O. Banta D-131 Jeanette Herron D-133 rd	Referred to Council on 09/05/2017
134-16	Comm.	Grant Submission: re State of Connecticut Office of Policy and Management Police and Youth Program for Urban Communities. (#18283)	Autumn Hurst, Grants Writer, Central Grants Office	Referred to Council on 09/05/2017
136-16 (Ref. #217-15)	Comm.	Proposed Sidewalk Repair Pilot Program Cost Estimates.	John Ricci, Director, Public Facilities	Referred to Council on 09/05/2017
137-16	Comm.	Proposed Letter of Commitment regarding FEMA National Flood Insurance Program Community Rating System (CRS).	John Urquidi, City Engineer	Referred to Council on 09/05/2017



WATER POLLUTION CONTROL AUTHORITY
for the City of Bridgeport

695 Seaview Avenue • Bridgeport, Connecticut 06607-1628
Telephone (203) 332-5550 • Fax (203) 576-7005

WILLIAM E. ROBINSON
Acting General Manager

COMM. #146-16 Ref'd to Ordinance Committee on 10/02/2017

MEMORANDUM

ATTEST
CITY CLERK

RECEIVED
CITY CLERKS OFFICE
17 SEP 25 PM 2:40

DATE: September 22, 2017

TO: Frances Ortiz, Assistant City Clerk

FROM: William E. Robinson, Acting General Manager

RE: Consideration of Amendment to Section 13.04.330 of the Bridgeport Code of Ordinances

At the regular meeting of the WPCA Board of Directors held on September 19, 2017, the Board considered a proposed modification to the Code of Ordinances to allow for the inclusion of a Residential Non-Discharge Rate.

At this meeting the Board approved this modification and requested the WPCA staff to transmit the proposed modification to the City Council for its consideration at its October 2, 2017 meeting.

Attached please find a copy of correspondence from the Office of the City Attorney, dated September 19, 2017, detailing the proposed modification.

Please advise if you require further information.

Attach (1)

Pc: Lydia Martinez, City Clerk
File

WER: 2017: 17 0922 memo FOrtiz A/City Clerk re amend Ordinance

CITY OF BRIDGEPORT
OFFICE OF THE CITY ATTORNEY

CITY ATTORNEY
R. Christopher Meyer

999 Broad Street
Bridgeport, Connecticut 06604-4328

DEPUTY CITY ATTORNEY
John P. Bohannon, Jr.

ASSOCIATE CITY ATTORNEYS

Mark T. Anastasi
Richard G. Kascah, Jr.
Bruce L. Levin
John R. Mitola
Lawrence A. Ouellette, Jr.
Tyisha S. Toms
Lisa R. Trachtenburg



ASSISTANT CITY ATTORNEYS

Eroll V. Skyers
Tamara J. Titre

OF COUNSEL

Russell Liskov
Ronald J. Pacacha

Telephone (203) 576-7647
Facsimile (203) 576-8252

September 19, 2017

Board of Directors
WPCA
695 Seaview Avenue
City of Bridgeport
Bridgeport, CT 06607

**Re: WPCA 9/19/17 Meeting Agenda – Item New Business D) Update on Residential
Non-Discharge Rate**

Dear Honorable Board Members:

You will recall that at the July 18, 2017 WPCA Board meeting, the Board:

- discussed the possibility of amending the Non-discharge Adjustment contained in Section 13.04.330 of the Municipal Code of Ordinances to include residential customers as well as the currently permitted commercial, industrial and institutional users; and
- voted to refer the matter to the City Attorney's Office to propose an amendment to the Code of Ordinances to permit the non-discharge adjustment be extended to residential customers.

Pursuant to your request, the City Attorney's Office proposes the following resolution for consideration at the September 19th WPCA Board meeting:

RESOLUTION

Whereas, the Bridgeport Code of Ordinances, does not currently authorize the WPCA to provide for a billing allowance for residential customers for metered water not discharged into the City's sewage system;

Now Therefore Be It Resolved: That the WPCA does hereby refer to the Bridgeport City Council the matter of whether to amend Section 13.04.330 of the Code of Ordinances to provide

authority to the WPCA to provide for a policy / procedure for allowance of residential customers to install a secondary meter for outdoor watering (lawn irrigation).

Be It Further Resolved: That in order to assist the City Council in its deliberations regarding this matter, the WPCA hereby proposes consideration of a new subsection B. to be added to the conclusion of Section 13.04.330 of the Code of Ordinances (set forth below) in the event the City Council determines to act favorably on this matter.

Bridgeport Code of Ordinances, Title 13 – Public Services

13.04.330 - Allowance for metered water not discharged into the city's sanitary sewer system.

A. Any commercial, industrial or institutional customer using a metered supply of water that is not discharged into the sanitary sewer system may petition the general manager for a billing adjustment provided that: such customer undertake, at its own expense, an engineering study to be performed by an engineer licensed in the state of Connecticut, the results of which shall be turned over to the general manager, indicating the volume of metered water consumed that is not returned to the sanitary sewer system. As an alternative to the aforementioned, such customer may install, at its own expense, a submeter, approved by the general manager, to measure flow into the sanitary sewer system. Such submeter shall be subject to periodic inspection by the WPCA to ensure its proper operation.

B. The WPCA is authorized in its discretion to establish procedures and fees to permit residential customers connected to the sewage system to install a secondary meter for outdoor watering (lawn irrigation). The supply of water recorded on such secondary meter that is not discharged into the sanitary sewer system will not be billed as part of a periodic charge per residential dwelling unit based upon water consumption.

(Ord. dated 5/5/14)

Very truly yours,



Mark T. Anastasi
Associate City Attorney

Cc: Joseph P. Ganim, Mayor
Thomas P. McCarthy, City Council President
Bill Robinson, WPCA GM
Stephen Walker, WPCA Dir. of Finance
R. Christopher Meyer, City Attorney
Russell D. Liskov, Esq.



JOSEPH P. GANIM
Mayor

City of Bridgeport, Connecticut
CENTRAL GRANTS OFFICE

999 Broad Street
Bridgeport, Connecticut 06604
Telephone (203) 332-5662
Fax (203) 332-5657

ISOLINA DeJESUS
Administrative Manager
Central Grants

**Comm. #148-16 Ref'd to ECD&E Committee
On 10/02/2017**

September 27, 2017

Office of the City Clerk
City of Bridgeport
45 Lyon Terrace, Room 204
Bridgeport, Connecticut 06604

RECEIVED
CITY CLERKS OFFICE
17 SEP 27 PM 12: 29
ATTEST
CITY CLERK

Re: Resolution – **CIRCA Municipal Resilience Grant Program - Bridgeport Resiliency Project (#18208)**

Attached, please find a Grant Summary and Resolution for the **CIRCA Municipal Resilience Grant Program - Bridgeport Resiliency Project (#18208)** to be referred to the **Committee on Economic and Community Development and Environment** of the City Council.

Grant: City of Bridgeport application to the **CIRCA Municipal Resilience Grant Program - Bridgeport Resiliency Project (#18208)**

If you have any questions or require any additional information please contact me at 203-332-5664 or autumn.hurst@bridgeportct.gov.

Thank you,

Autumn Hurst
Central Grants Office



GRANT SUMMARY

PROJECT TITLE: **CIRCA Municipal Resilience Grant Program - Bridgeport Resiliency Project (#18208)**

NEW RENEWAL CONTINUING

DEPARTMENT SUBMITTING INFORMATION: **Central Grants Office**

CONTACT NAME: **Autumn Hurst**

PHONE NUMBER: **203-332-5664**

PROJECT SUMMARY/DESCRIPTION: The City of Bridgeport's Office of Emergency Management and Homeland Security seeks funding from the Connecticut Institute for Resilience and Climate Adaptation (CIRCA) to support its Bridgeport Resiliency Project. The Project will utilize assessment and resource development and identification tools to enhance local long-term disaster recovery across the city resulting in:

- The creation of a long-term recovery framework that identifies responsibilities and resources of City Departments, businesses, and non-governmental organizations and addresses vulnerabilities;
- A resource recovery booklet/resource manual that includes a directory of city-wide recovery resources to be distributed to local organizations and community members both pre- and post-disaster; and
- A technology component that will include the creation of an interactive evacuation route planning website and City of Bridgeport Emergency Management smartphone application that the community can utilize for emergency education, planning, and communication.

CONTRACT PERIOD: January 2018 – December 2018 (expected)

FUNDING SOURCES

Federal	\$0	
State	\$0	
City	\$0	
Other	\$50,000	CIRCA
Total	\$50,000	

GRANT FUNDS REQUESTED

Travel	\$5,000	OEMHS staff attendance at preparedness/resiliency conferences
Consultants	\$45,000	Creation of recovery framework, resource manual, and technology component
Total	\$50,000	

A Resolution by the Bridgeport City Council

Regarding the

CIRCA Municipal Resilience Grant Program

Bridgeport Resiliency Project (#18208)

WHEREAS, the Connecticut Institute for Resilience and Climate Adaptation (CIRCA) is authorized to extend financial assistance to municipalities in the form of grants; and

WHEREAS, this funding has been made possible through the Municipal Resilience Grant Program; and

WHEREAS, funds under this grant will be used to support efforts to improve city-wide disaster resiliency and recovery; and

WHEREAS, it is desirable and in the public interest that the City of Bridgeport submits an application to CIRCA to support the Bridgeport Resiliency Project.

NOW THEREFORE, BE IT HEREBY RESOLVED BY THE CITY COUNCIL:

1. That it is cognizant of the City's grant application to and contract with **CIRCA** for the purpose of its **Municipal Resilience Grant Program**; and
2. That it hereby authorizes, directs and empowers the Mayor or his designee, the **Central Grants Director**, to execute and file such application with **CIRCA** and to provide such additional information and to execute such other contracts, amendments, and documents as may be necessary to administer this program.



City of Bridgeport, Connecticut
CENTRAL GRANTS OFFICE

999 Broad Street
Bridgeport, Connecticut 06604
Telephone (203) 332-5662
Fax (203) 332-5657

ISOLINA DeJESUS
Administrative Manager
Central Grants

JOSEPH P. GANIM
Mayor

**Comm. #149-16 Ref'd to ECD&E Committee
On 10/02/2017**

RECEIVED
CITY CLERKS OFFICE
17 SEP 27 PM 12:29
ATTEST
CITY CLERK

September 27, 2017

Office of the City Clerk
City of Bridgeport
45 Lyon Terrace, Room 204
Bridgeport, Connecticut 06604

Re: Resolution – CIRCA Municipal Resilience Grant Program – Mirror Lake Coastal Wetland Restoration (#18224)

Attached, please find a Grant Summary and Resolution for the CIRCA Municipal Resilience Grant Program - Mirror Lake Coastal Wetland Restoration (#18224) to be referred to the Committee on Economic and Community Development and Environment of the City Council.

Grant: City of Bridgeport application to the CIRCA Municipal Resilience Grant Program - Mirror Lake Coastal Wetland Restoration (#18224)

If you have any questions or require any additional information please contact me at 203-332-5664 or autumn.hurst@bridgeportct.gov.

Thank you,

Autumn Hurst
Central Grants Office



GRANT SUMMARY

PROJECT TITLE: **CIRCA Municipal Resilience Grant Program - Mirror Lake Coastal Wetland Restoration (#18224)**

NEW RENEWAL CONTINUING

DEPARTMENT SUBMITTING INFORMATION: **Central Grants Office**

CONTACT NAME: **Autumn Hurst**

PHONE NUMBER: **203-332-5664**

PROJECT SUMMARY/DESCRIPTION: The City of Bridgeport’s Parks Department seeks funding from the Connecticut Institute for Resilience and Climate Adaptation (CIRCA) to support its Mirror Lake Coastal Wetland Restoration Project. The project will result in a conceptual design for the renovation of the manmade Mirror Lake area within Seaside Park (currently cut off from Long Island Sound by the berm beneath Soundview Drive) back into an historic coastal wetland and public park connected to the Sound. The project will ultimately improve Seaside Park’s ability to protect the South End neighborhood from storm surge and inundation following incidents of sea level rise.

CONTRACT PERIOD: November 2017 – November 2018 (expected)

FUNDING SOURCES

Federal	\$0	
State	\$0	
City	\$2,000	In-Kind Parks & Public Facilities staff support
Other	\$35,000	CIRCA
	\$32,500	In-Kind leverage from project partners
Total	\$50,000	

GRANT FUNDS REQUESTED

Consultants	\$35,000	Project management and design coordination and completion
Other	\$0	
Total	\$35,000	

A Resolution by the Bridgeport City Council

Regarding the

CIRCA Municipal Resilience Grant Program

Mirror Lake Coastal Wetland Restoration (#18224)

WHEREAS, the **Connecticut Institute for Resilience and Climate Adaptation (CIRCA)** is authorized to extend financial assistance to municipalities in the form of grants; and

WHEREAS, this funding has been made possible through the **Municipal Resilience Grant Program**; and

WHEREAS, funds under this grant will be used to support efforts to create conceptual design for the renovation of the Mirror Lake area within Seaside Park; and

WHEREAS, it is desirable and in the public interest that the City of Bridgeport submits an application to **CIRCA** to support the Mirror Lake Coastal Wetland Restoration project.

NOW THEREFORE, BE IT HEREBY RESOLVED BY THE CITY COUNCIL:

1. That it is cognizant of the City's grant application to and contract with **CIRCA** for the purpose of its **Municipal Resilience Grant Program**; and
2. That it hereby authorizes, directs and empowers the Mayor or his designee, the **Central Grants Director**, to execute and file such application with **CIRCA** and to provide such additional information and to execute such other contracts, amendments, and documents as may be necessary to administer this program.

**CITY OF BRIDGEPORT
OFFICE OF THE CITY ATTORNEY**

**CITY ATTORNEY
R. Christopher Meyer**

**DEPUTY CITY ATTORNEY
John P. Bohannon, Jr.**

ASSOCIATE CITY ATTORNEYS

**Mark T. Anastasi
Richard G. Kascak, Jr.
Bruce L. Levin
John R. Mitola
Lawrence A. Ouellette, Jr.
Tyisha S. Toms
Lisa R. Trachtenburg**

**999 Broad Street
Bridgeport, CT 06604-4328**



ASSISTANT CITY ATTORNEYS

**Eroll V. Skyers
Tamara J. Titre**

**OF COUNSEL
Russell D. Liskov
Ronald J. Pacacha**

**Telephone (203) 576-7647
Facsimile (203) 576-8252**

COMM. #150-16 Ref'd to Contracts Committee on 10/02/2017.

September 27, 2017

City Council
c/o City Clerk's Office
45 Lyon Terrace
Bridgeport, CT 06604

**Re: University of Bridgeport License to Use and Improve Diamond
No. 1 at Seaside Park**

Dear Madam Clerk:

The attached item is for referral to the Contracts Committee. Public Facilities and the City's Attorney's Office will be available to discuss with the Committee. Thank you.

Kind regards,

Tyisha S. Toms
Associate City Attorney

RECEIVED
CITY CLERKS OFFICE
17 SEP 28 AM 9:57
ATTEST
CITY CLERK

**SEASIDE PARK DIAMOND #1
LICENSING AGREEMENT RESOLUTION**

WHEREAS, the University of Bridgeport (“UB”) desires to improve and use Diamond #1 at Seaside Park for its baseball team; and

WHEREAS, the City of Bridgeport (“City”) agrees to allow UB to use Diamond #1 as desired pursuant to the Agreement attached hereto as Exhibit A; and

WHEREAS, the Parties agree to share the cost of making Diamond #1 NCAA compliant as UB will match the City’s expenditure on a 2:1 basis up to a total of \$600,000 on UB’s part with a maximum contribution in the amount of \$300,000 from the City; and

WHEREAS, in consideration for the aforementioned expenditures, the City will grant UB a license to use Diamond #1 for baseball practices and games from February 1 through May 1 (or longer in the case that the Team qualifies for the NCAA playoffs); and

WHEREAS, the Agreement shall commence when executed and continue for a period of 15 years unless otherwise terminated with the option to extend for an additional 15 years; and

WHEREAS, the effectiveness of this Agreement is contingent upon the availability of funding; and

WHEREAS, the conceptual site plan for the reconstruction of Diamond #1 was unanimously approved by the Parks Board on July 11, 2017.

NOW THEREFORE, BE IT HEREBY RESOLVED, BY THE City Council:

1. That it is cognizant of the City’s plans to allow UB to use and improve Diamond #1 at Seaside Park.
2. That it hereby authorizes, directs and empowers the Mayor or his designee, the Director of Public Facilities, to execute such Licensing Agreement and other documents as may be necessary to facilitate the use and improvement of Diamond #1 to a NCAA compliant baseball field.

LICENSING AGREEMENT
BETWEEN
UNIVERSITY OF BRIDGEPORT
AND
CITY OF BRIDGEPORT
AND ITS
BOARD OF PARKS COMMISSIONERS

This agreement (“Agreement”) is entered into between the City of Bridgeport, the Board of Park Commissioners, acting through the Department of Public Facilities of the City of Bridgeport, having an address at Margaret E. Morton Government Center, 999 Broad Street, 2nd Floor, Bridgeport, CT 06604 (“City”) and the University of Bridgeport, a private university organized under the laws of the State of Connecticut, having an address at 126 Park Avenue, Bridgeport, CT 06605 (“UB”) with respect to making physical improvements to the baseball field at Seaside Park shown on Exhibit 1 attached hereto (the field, together with the surrounding area, hereafter described as “Diamond #1”) to install an NCAA-compliant baseball field which UB will utilize for the limited number of months each year for practices/games for its NCAA men’s baseball team (“Team”) while allowing unrestricted use to the City at all other times.

NOW THEREFORE, for good and valuable consideration, each received by the other, the parties hereby agree as follows:

1. License to Use the Diamond. In consideration for expenditures (as defined below) toward agreed improvements to Diamond #1, as reflected in Exhibit 1, together with annual pre-season maintenance and in-season grooming as set forth below, the City grants a license to UB to use Diamond #1 for Team baseball practices and games from February 1 through May 1 (or longer in the case that the Team qualifies for NCAA playoffs) and during the Fall semester (collectively hereafter referred to as the “Season”) of each year during the Term (defined below).

2. Term. This Agreement shall commence upon signing and continue for a period of fifteen (15) years (“Term”), unless sooner terminated by either party as set forth herein.

a. Extension Option. Either Party shall have the right to renew the Term for an additional fifteen (15) years upon providing the other Party with notice of its intent to renew within three hundred sixty five (365) days of the expiration of the Term.

3. Improvements. (a.) Both parties agree to contribute monetary payments and/or material or services of value (hereafter “expenditures”) to accomplish the agreed upon improvements reflected in Exhibit 1 to Diamond #1 in a accordance with a mutually agreed upon Budget and schedule. UB will match the City’s expenditures on a 2:1 basis up to a total expenditure of \$600,000 on UB’s part. (b.) The improvements shall be NCAA compliant. (c.) UB shall supervise the improvements in collaboration with City. (d.) As funding permits, UB will continue to improve Diamond #1 and it agrees to obtain prior written approval from the City for any and all improvements beyond those specified in Exhibit 1.

4. Maintenance.

(a.) UB agrees to maintain all playing surfaces year-round, secure the fence and UB campus security will patrol the area while in use by UB.

(b.) City agrees to maintain the areas around the playing field and to remove litter and leaves.

(c.) City shall retain general responsibility for safety inspection, off-season care and maintenance of Diamond #1, including providing appropriate security. For the purposes of this provision, security shall include securing the fence around the field during UB's off-season and providing the same level and manner of security generally provided by the City in all parks.

(d.) Capital Reserve Account means a jointly-owned bank account established for the deposit of funds to be used for repair and maintenance expenses in excess of \$5,000 that are not covered by insurance. No expenditure shall be made out of the Capital Reserve Account without the expressed written consent of both Parties.

(i) The Capital Reserve Account Contribution(s) means the initial contribution of \$ 5,000 by each party in the Capital Reserve Account, to be deposited into the joint bank account for the first five (5) years during the Term up to a maximum of \$ 50,000, after which the Parties shall make equal annual contributions to maintain the account at such funding levels. At the termination and/or expiration of this Agreement the Parties shall evenly split the funds remaining in the Capital Reserve Account.

5. Scheduling. In order to facilitate and coordinate scheduling events at the Diamond #1, the parties agree to meet in August or September of each year during the Term. UB shall have priority during the Season and City may schedule events during other times of the year when UB is not using Diamond #1.

6. Liability and Insurance. (a.) UB shall be responsible for any and all claims arising out of or relating to its use of Diamond #1 and shall indemnify and hold the City harmless from any such claims. (b.) City shall be responsible for any and all claims arising out of or relating to Diamond #1 except when UB is using the facility and shall indemnify and hold the UB harmless from any such claims. (c.) Both parties shall arrange reasonable general liability insurance coverage or shall provide evidence of self-insurance. Specifically, UB shall insure the improvements to Diamond #1, name the City as an additional insured by certificate and policy endorsement and provide proof thereof.

7. Disputes. All disputes, if they cannot be resolved amicably at a staff level, shall be resolved by a meeting, called by a party on fifteen (15) days prior written notice, among the City's Mayor, the Chairman of the Board of Parks Commissioners, and the President of UB, or their respective designees. If the parties cannot come to agreement within thirty (30) days after such meeting is called, whether or not the meeting is held, any controversy or claim arising out of or relating to this agreement, or the breach thereof, shall be resolved in a court of competent jurisdiction over the parties located in Fairfield County.

8. Termination. Either party may terminate this Agreement without cause upon a minimum of 365 days written notice to the other party, provided that if the City elects to terminate the Agreement without cause during the Term it shall first reimburse UB for the unamortized portion of UB expenditures paid pursuant to this Agreement based upon the unexpired portion of the Term as of the Termination Date.

9. Notice. Any notice desired or required to be given hereunder shall be given in writing and shall be either hand-delivered, delivered by overnight courier service, or shall be mailed in a post-paid envelope addressed to the other party and deposited in a mailbox operated by the United States Postal Service to the following addresses:

If to the City:

At the address first set forth above, Attention: Mayor.

With a copy to:

City Attorney
Margaret E. Morton Government Center
999 Broad Street, 2nd Floor
Bridgeport, CT 06604

If to UB:

At the address first set forth above, Attention: University President.

With a copy to:

Carolyn Linsey, General Counsel, at the address set forth above.

10. Non-discrimination.

(a.) UB shall not discriminate or permit discrimination against any person or group of persons on the grounds of race, color, religious creed, age, sexual orientation, marital status, national origin, sex, mental retardation or physical disability, including, but not limited to blindness, in the use of Diamond #1 or any improvements to be erected thereon, and shall not effect or execute any agreement, lease, conveyance, or other instrument whereby Diamond #1 or any part thereof is restricted on the basis of race, color, religious creed, age, sexual orientation, marital status, national origin, sex, mental retardation or physical disability, including, but not limited to blindness, in the use thereof. UB shall comply with all state, and local laws, in effect from time to time, prohibiting discrimination or segregation by reason of race, color, religious creed, age, sexual orientation, marital status, national origin, sex, mental retardation or physical disability, including, but not limited to, blindness, in the use of Diamond #1.

This agreement requires the approval of the Board of Parks Commissioners and the Bridgeport City Council and shall become effective upon delivery of a fully-executed original to UB.

IN WITNESS WHEREOF, the parties have set forth their hands and seals on this ____ day of _____, 2017.

CITY OF BRIDGEPORT

By: _____
Name:
Title:

UNIVERSITY OF BRIDGEPORT

By: _____
Name:
Title:

BOARD OF PARKS COMMISSIONERS

By: _____
Name:
Title:

Exhibit 1

Description of Diamond and Improvements

SOIL TEST DATA
 REPORTED BY: M & M
 DATE: 08/20/17

HOWE DRIVE

TEST PT. NO.	DEPTH	SOIL DESCRIPTION
P1	0'-15"	LOOSE TOPSOIL
	0'-18"	LOOSE BROWN/GRAY FINE SAND, LITTLE TO SOME SILT
	2'-3"	MEDIUM DENSE, BROWN/GRAY FINE SAND, LITTLE TO SOME SILT
	3'-0"	MEDIUM DENSE, LIGHT BROWN FINE TO COARSE SAND, SOME FINE TO COARSE GRAVEL
	3'-6"	MEDIUM DENSE, DARK BROWN FINE TO MEDIUM SAND, SOME SILT, LITTLE FINE GRAVEL
P2	0'-15"	LOOSE TOPSOIL
	0'-18"	LOOSE BROWN/GRAY FINE SAND, LITTLE TO SOME SILT
	2'-3"	MEDIUM DENSE, BROWN/GRAY FINE SAND, LITTLE TO SOME SILT
	3'-0"	MEDIUM DENSE, LIGHT BROWN FINE TO COARSE SAND, LITTLE TO MEDIUM GRAVEL, TRACE SILT
	3'-6"	LOOSE LIGHT BROWN FINE TO COARSE SAND, LITTLE TO MEDIUM GRAVEL, TRACE SILT
P3	0'-15"	LOOSE TOPSOIL
	0'-18"	LOOSE BROWN/GRAY FINE SAND, LITTLE TO SOME SILT
	2'-3"	MEDIUM DENSE, BROWN/GRAY FINE SAND, LITTLE TO SOME SILT
	3'-0"	MEDIUM DENSE, LIGHT BROWN FINE TO COARSE SAND, LITTLE TO MEDIUM GRAVEL, TRACE SILT
	3'-6"	MEDIUM DENSE, DARK BROWN FINE TO MEDIUM SAND, SOME SILT, LITTLE FINE GRAVEL
P4	0'-15"	LOOSE TOPSOIL
	0'-18"	LOOSE BROWN/GRAY FINE SAND, LITTLE TO SOME SILT
	2'-3"	MEDIUM DENSE, BROWN/GRAY FINE SAND, LITTLE TO SOME SILT
	3'-0"	MEDIUM DENSE, LIGHT BROWN FINE TO COARSE SAND, LITTLE TO MEDIUM GRAVEL, TRACE SILT
	3'-6"	MEDIUM DENSE, DARK BROWN FINE TO MEDIUM SAND, SOME SILT, LITTLE FINE GRAVEL

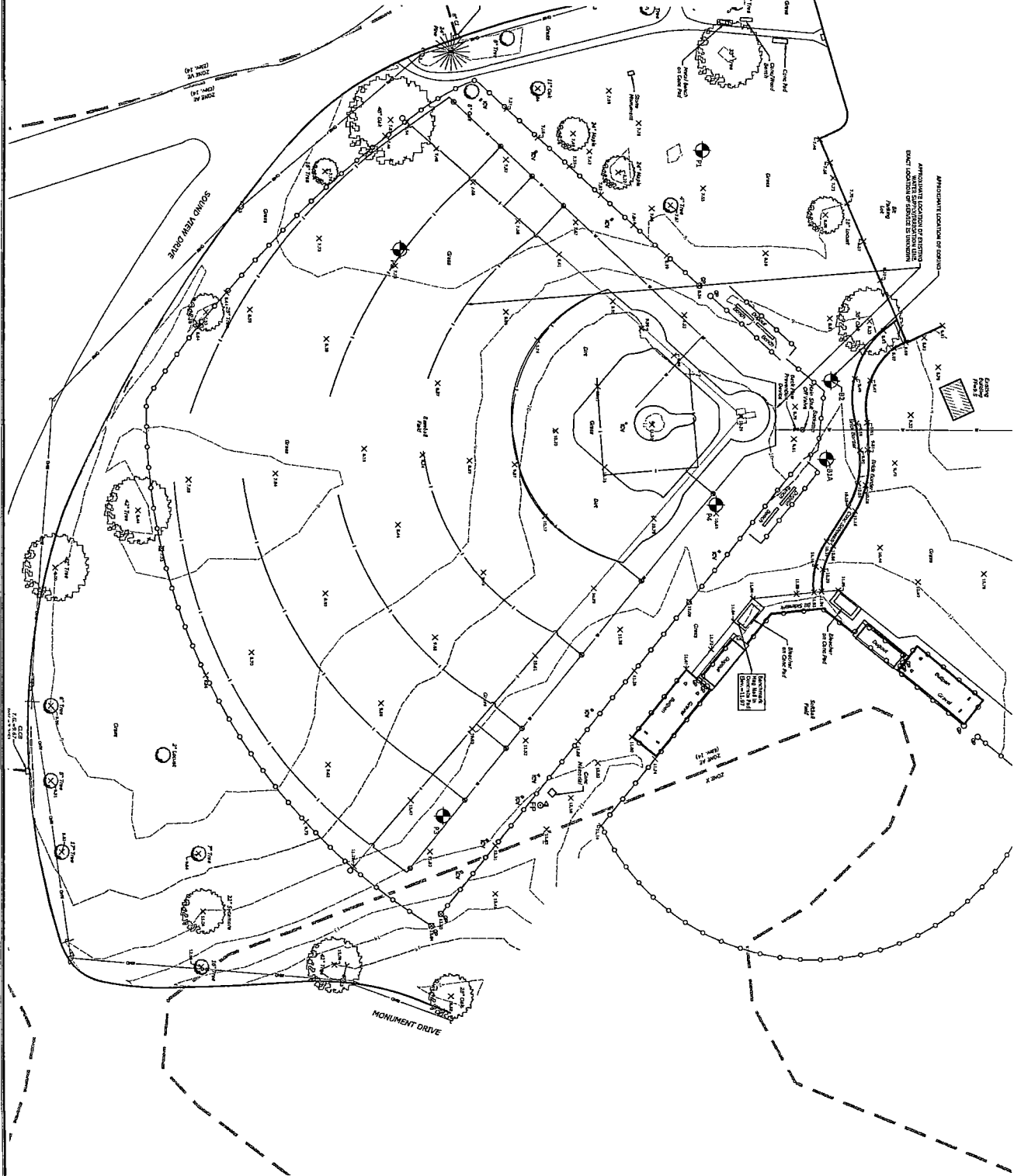

EXISTING CONDITIONS
 UNIVERSITY OF BRIDGEPORT
 BASEBALL FIELD IMPROVEMENTS
 SOUND VIEW DRIVE
 BRIDGEPORT, CONNECTICUT

DESCRIPTION	DATE	BY

MILONE & MACBROOM[®]
 99 Reedy Drive
 Cheshire, Connecticut 06410
 (203) 271-1773 Fax (203) 272-9723
 www.miloneandmacbroom.com

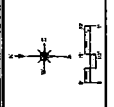

MILONE & MACBROOM
 99 Realty Drive
 Cheshire, Connecticut 06018
 (860) 271-1728 Fax: (860) 271-9733
 www.miloneandmacbroom.com

DESCRIPTION	DATE	BY

SITE PLAN - GRADING AND SEDIMENT AND EROSION CONTROLS
UNIVERSITY OF BRIDGEPORT
BASEBALL FIELD IMPROVEMENTS
 BRIDGEPORT, CONNECTICUT

DATE	DESCRIPTION	BY
1/20/07		
AUGUST 29, 2017		
2018-02		

GR

SOIL EROSION AND SEDIMENT CONTROL WARRANTIVE
 The proposed construction project shall be a completed and fully installed erosion and sediment control system. The contractor shall be responsible for the design, construction, and maintenance of the system. The system shall be designed to prevent erosion and sediment from leaving the site during construction. The system shall be installed in accordance with the following specifications:
 1. EROSION CONTROL SYSTEM SHALL BE DESIGNED TO PREVENT EROSION AND SEDIMENT FROM LEAVING THE SITE DURING CONSTRUCTION.
 2. THE SYSTEM SHALL BE INSTALLED IN ACCORDANCE WITH THE FOLLOWING SPECIFICATIONS:
 a) EROSION CONTROL SYSTEM SHALL BE DESIGNED TO PREVENT EROSION AND SEDIMENT FROM LEAVING THE SITE DURING CONSTRUCTION.
 b) THE SYSTEM SHALL BE INSTALLED IN ACCORDANCE WITH THE FOLLOWING SPECIFICATIONS:
 c) THE SYSTEM SHALL BE MAINTAINED THROUGHOUT THE CONSTRUCTION PERIOD AND SHALL BE RESTORED TO ORIGINAL OR BETTER CONDITION AT THE END OF CONSTRUCTION.
 3. THE SYSTEM SHALL BE MAINTAINED THROUGHOUT THE CONSTRUCTION PERIOD AND SHALL BE RESTORED TO ORIGINAL OR BETTER CONDITION AT THE END OF CONSTRUCTION.
 4. THE SYSTEM SHALL BE MAINTAINED THROUGHOUT THE CONSTRUCTION PERIOD AND SHALL BE RESTORED TO ORIGINAL OR BETTER CONDITION AT THE END OF CONSTRUCTION.
 5. THE SYSTEM SHALL BE MAINTAINED THROUGHOUT THE CONSTRUCTION PERIOD AND SHALL BE RESTORED TO ORIGINAL OR BETTER CONDITION AT THE END OF CONSTRUCTION.
 6. THE SYSTEM SHALL BE MAINTAINED THROUGHOUT THE CONSTRUCTION PERIOD AND SHALL BE RESTORED TO ORIGINAL OR BETTER CONDITION AT THE END OF CONSTRUCTION.
 7. THE SYSTEM SHALL BE MAINTAINED THROUGHOUT THE CONSTRUCTION PERIOD AND SHALL BE RESTORED TO ORIGINAL OR BETTER CONDITION AT THE END OF CONSTRUCTION.
 8. THE SYSTEM SHALL BE MAINTAINED THROUGHOUT THE CONSTRUCTION PERIOD AND SHALL BE RESTORED TO ORIGINAL OR BETTER CONDITION AT THE END OF CONSTRUCTION.
 9. THE SYSTEM SHALL BE MAINTAINED THROUGHOUT THE CONSTRUCTION PERIOD AND SHALL BE RESTORED TO ORIGINAL OR BETTER CONDITION AT THE END OF CONSTRUCTION.
 10. THE SYSTEM SHALL BE MAINTAINED THROUGHOUT THE CONSTRUCTION PERIOD AND SHALL BE RESTORED TO ORIGINAL OR BETTER CONDITION AT THE END OF CONSTRUCTION.

- EROSION CONTROL LEGEND**
- CONSTRUCTION ENTRANCE
 - SEDIMENT FILTER FENCE
 - STORMWATER DETENTION BASIN
 - SOIL STABILIZATION AREA
 - SOIL PROTECTION
 - CONSTRUCTION ENTRANCE
 - SEDIMENT FILTER FENCE
 - STORMWATER DETENTION BASIN
 - SOIL STABILIZATION AREA
 - SOIL PROTECTION
- GRADING AND DRAINAGE LEGEND**
- PERMANENT COLLECTION PIPE
 - 1% SLOPE
 - 2% SLOPE
 - 3% SLOPE
 - 4% SLOPE
 - 5% SLOPE
 - 6% SLOPE
 - 7% SLOPE
 - 8% SLOPE
 - 9% SLOPE
 - 10% SLOPE
 - 11% SLOPE
 - 12% SLOPE
 - 13% SLOPE
 - 14% SLOPE
 - 15% SLOPE
 - 16% SLOPE
 - 17% SLOPE
 - 18% SLOPE
 - 19% SLOPE
 - 20% SLOPE
 - 21% SLOPE
 - 22% SLOPE
 - 23% SLOPE
 - 24% SLOPE
 - 25% SLOPE
 - 26% SLOPE
 - 27% SLOPE
 - 28% SLOPE
 - 29% SLOPE
 - 30% SLOPE
 - 31% SLOPE
 - 32% SLOPE
 - 33% SLOPE
 - 34% SLOPE
 - 35% SLOPE
 - 36% SLOPE
 - 37% SLOPE
 - 38% SLOPE
 - 39% SLOPE
 - 40% SLOPE
 - 41% SLOPE
 - 42% SLOPE
 - 43% SLOPE
 - 44% SLOPE
 - 45% SLOPE
 - 46% SLOPE
 - 47% SLOPE
 - 48% SLOPE
 - 49% SLOPE
 - 50% SLOPE
 - 51% SLOPE
 - 52% SLOPE
 - 53% SLOPE
 - 54% SLOPE
 - 55% SLOPE
 - 56% SLOPE
 - 57% SLOPE
 - 58% SLOPE
 - 59% SLOPE
 - 60% SLOPE
 - 61% SLOPE
 - 62% SLOPE
 - 63% SLOPE
 - 64% SLOPE
 - 65% SLOPE
 - 66% SLOPE
 - 67% SLOPE
 - 68% SLOPE
 - 69% SLOPE
 - 70% SLOPE
 - 71% SLOPE
 - 72% SLOPE
 - 73% SLOPE
 - 74% SLOPE
 - 75% SLOPE
 - 76% SLOPE
 - 77% SLOPE
 - 78% SLOPE
 - 79% SLOPE
 - 80% SLOPE
 - 81% SLOPE
 - 82% SLOPE
 - 83% SLOPE
 - 84% SLOPE
 - 85% SLOPE
 - 86% SLOPE
 - 87% SLOPE
 - 88% SLOPE
 - 89% SLOPE
 - 90% SLOPE
 - 91% SLOPE
 - 92% SLOPE
 - 93% SLOPE
 - 94% SLOPE
 - 95% SLOPE
 - 96% SLOPE
 - 97% SLOPE
 - 98% SLOPE
 - 99% SLOPE
 - 100% SLOPE

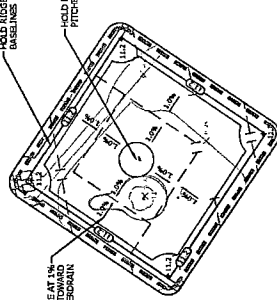
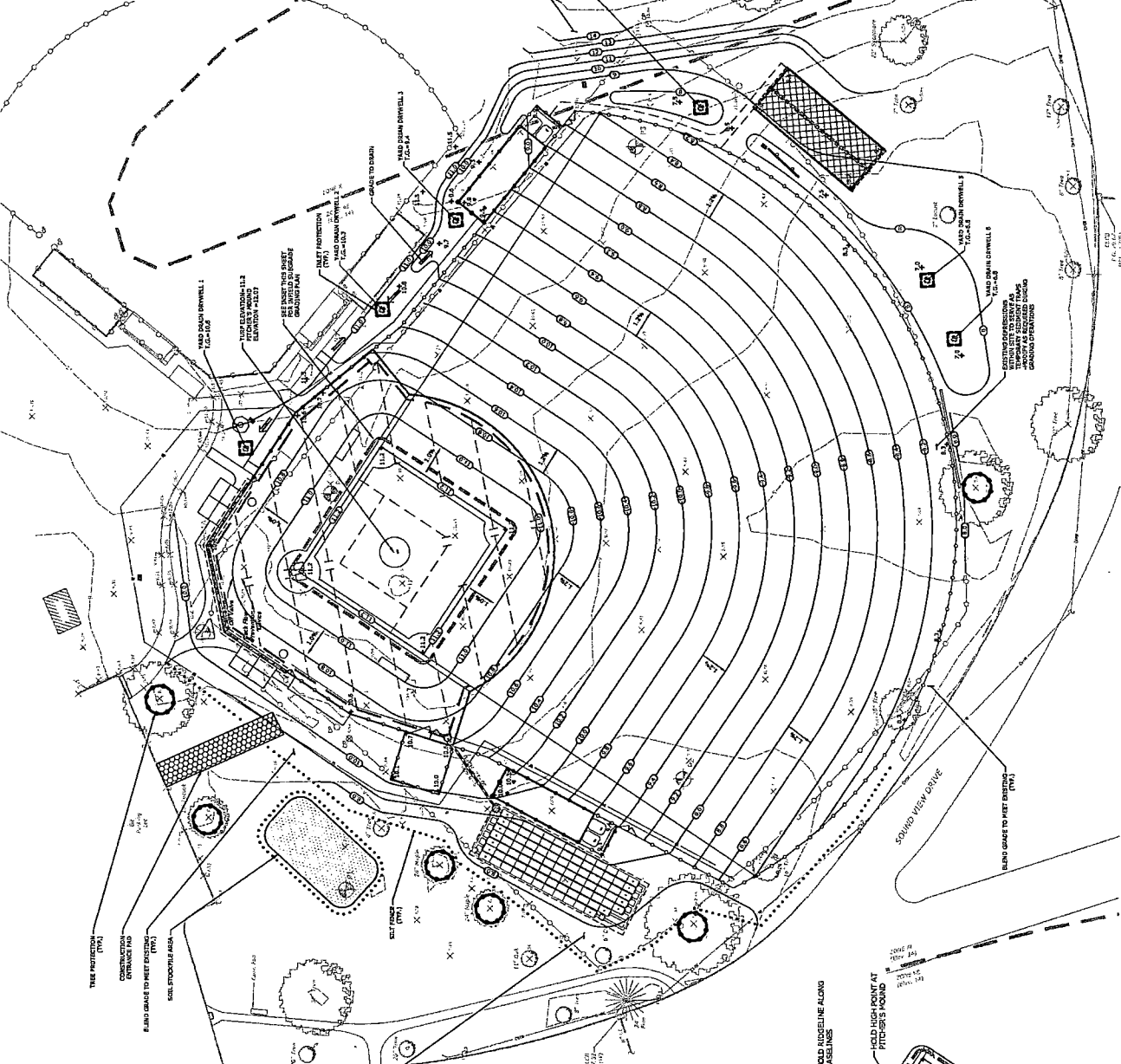

INSET
INFIELD GRADING PLAN
 SCALE: 1/4" = 1'-0"

1. ALL DIMENSIONS ARE IN FEET AND DECIMALS THEREOF.
 2. ALL ELEVATIONS ARE IN FEET ABOVE MEAN SEA LEVEL UNLESS OTHERWISE NOTED.
 3. ALL SLOPES ARE PERCENT UNLESS OTHERWISE NOTED.
 4. ALL DISTANCES ARE IN FEET AND DECIMALS THEREOF UNLESS OTHERWISE NOTED.
 5. ALL ANGLES ARE IN DEGREES AND DECIMALS THEREOF UNLESS OTHERWISE NOTED.
 6. ALL CURVES ARE CIRCULAR UNLESS OTHERWISE NOTED.
 7. ALL UTILITIES SHOWN ARE AS LOCATED BY FIELD SURVEY UNLESS OTHERWISE NOTED.
 8. ALL UTILITIES NOT SHOWN ARE AS SHOWN ON RECORD PLANS.
 9. ALL UTILITIES NOT SHOWN ARE AS SHOWN ON RECORD PLANS.
 10. ALL UTILITIES NOT SHOWN ARE AS SHOWN ON RECORD PLANS.

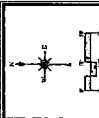

MILONE & MACBROOM
 99 Rocky Drive
 Cheshire, Connecticut 06610
 (203) 271-1773 Fax: (203) 273-7733
 www.miloneandmacbroom.com

DESCRIPTION	DATE BY

SITE PLAN - UTILITIES
 UNIVERSITY OF BRIDGEPORT
 BASEBALL FIELD IMPROVEMENTS
 SOUND VIEW DRIVE
 BRIDGEPORT, CONNECTICUT

CBR	WAR	DJK
DATE	PROJECT	SCALE
AUGUST 29, 2017	UNIVERSITY OF BRIDGEPORT BASEBALL FIELD IMPROVEMENTS	1"=50'-0"
DRAWN BY	CHECKED BY	DATE

UT

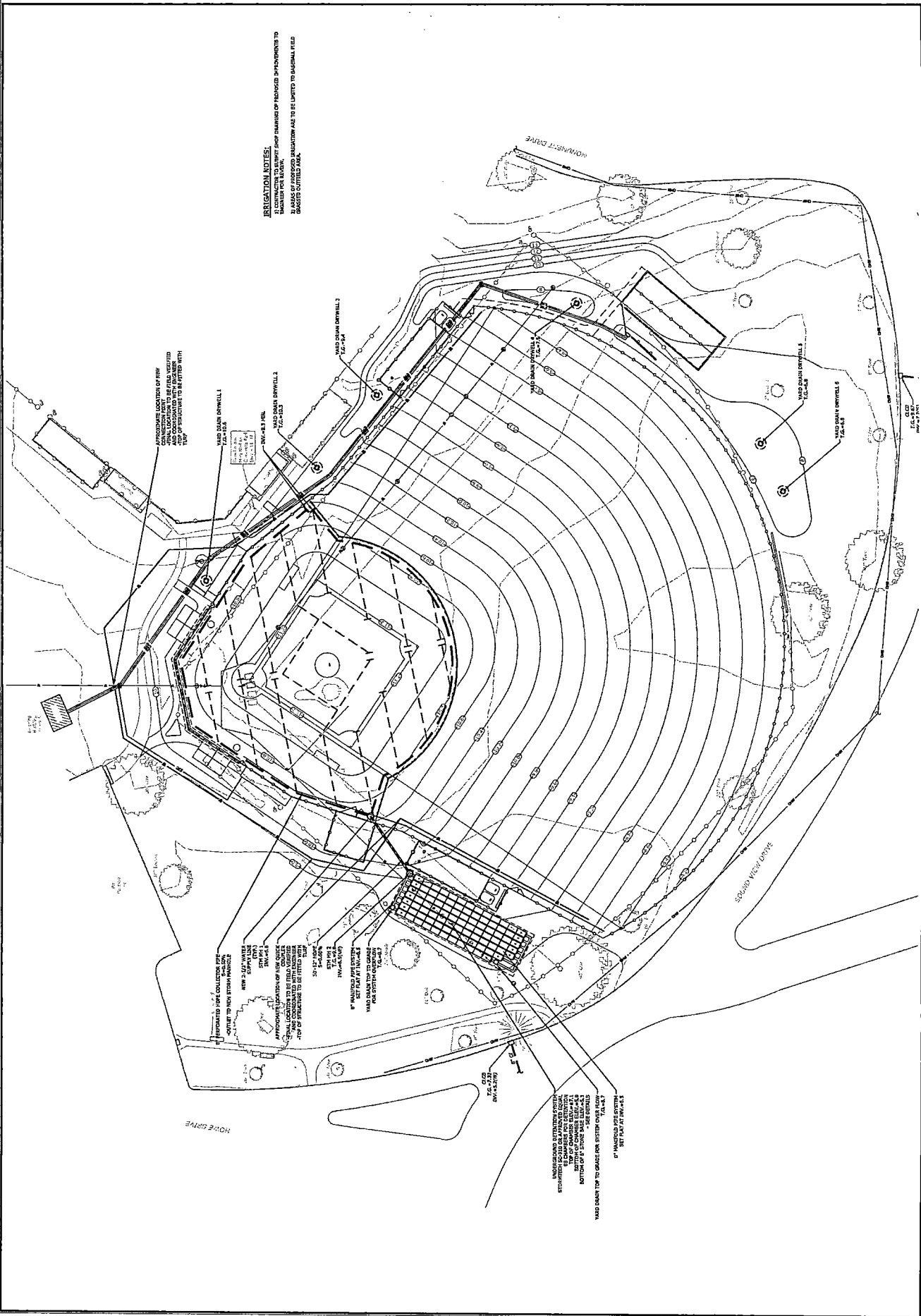

IRIGATION NOTES:
 1. APPROXIMATE LOCATION OF NEW IRRIGATION SYSTEM SHOWN BY DASHED IMPROVEMENTS TO EXISTING IRRIGATION SYSTEM.
 2. AREAS OF PROPOSED IRRIGATION ARE TO BE LIMITED TO BASEBALL FIELD AND ADJACENT AREAS.

APPROXIMATE LOCATION OF NEW IRRIGATION SYSTEM SHOWN BY DASHED IMPROVEMENTS TO EXISTING IRRIGATION SYSTEM.
 AREAS OF PROPOSED IRRIGATION ARE TO BE LIMITED TO BASEBALL FIELD AND ADJACENT AREAS.

APPROXIMATE LOCATION OF NEW IRRIGATION SYSTEM SHOWN BY DASHED IMPROVEMENTS TO EXISTING IRRIGATION SYSTEM.
 AREAS OF PROPOSED IRRIGATION ARE TO BE LIMITED TO BASEBALL FIELD AND ADJACENT AREAS.

APPROXIMATE LOCATION OF NEW IRRIGATION SYSTEM SHOWN BY DASHED IMPROVEMENTS TO EXISTING IRRIGATION SYSTEM.
 AREAS OF PROPOSED IRRIGATION ARE TO BE LIMITED TO BASEBALL FIELD AND ADJACENT AREAS.

APPROXIMATE LOCATION OF NEW IRRIGATION SYSTEM SHOWN BY DASHED IMPROVEMENTS TO EXISTING IRRIGATION SYSTEM.
 AREAS OF PROPOSED IRRIGATION ARE TO BE LIMITED TO BASEBALL FIELD AND ADJACENT AREAS.

APPROXIMATE LOCATION OF NEW IRRIGATION SYSTEM SHOWN BY DASHED IMPROVEMENTS TO EXISTING IRRIGATION SYSTEM.
 AREAS OF PROPOSED IRRIGATION ARE TO BE LIMITED TO BASEBALL FIELD AND ADJACENT AREAS.

APPROXIMATE LOCATION OF NEW IRRIGATION SYSTEM SHOWN BY DASHED IMPROVEMENTS TO EXISTING IRRIGATION SYSTEM.
 AREAS OF PROPOSED IRRIGATION ARE TO BE LIMITED TO BASEBALL FIELD AND ADJACENT AREAS.

APPROXIMATE LOCATION OF NEW IRRIGATION SYSTEM SHOWN BY DASHED IMPROVEMENTS TO EXISTING IRRIGATION SYSTEM.
 AREAS OF PROPOSED IRRIGATION ARE TO BE LIMITED TO BASEBALL FIELD AND ADJACENT AREAS.

APPROXIMATE LOCATION OF NEW IRRIGATION SYSTEM SHOWN BY DASHED IMPROVEMENTS TO EXISTING IRRIGATION SYSTEM.
 AREAS OF PROPOSED IRRIGATION ARE TO BE LIMITED TO BASEBALL FIELD AND ADJACENT AREAS.

APPROXIMATE LOCATION OF NEW IRRIGATION SYSTEM SHOWN BY DASHED IMPROVEMENTS TO EXISTING IRRIGATION SYSTEM.
 AREAS OF PROPOSED IRRIGATION ARE TO BE LIMITED TO BASEBALL FIELD AND ADJACENT AREAS.

APPROXIMATE LOCATION OF NEW IRRIGATION SYSTEM SHOWN BY DASHED IMPROVEMENTS TO EXISTING IRRIGATION SYSTEM.
 AREAS OF PROPOSED IRRIGATION ARE TO BE LIMITED TO BASEBALL FIELD AND ADJACENT AREAS.

APPROXIMATE LOCATION OF NEW IRRIGATION SYSTEM SHOWN BY DASHED IMPROVEMENTS TO EXISTING IRRIGATION SYSTEM.
 AREAS OF PROPOSED IRRIGATION ARE TO BE LIMITED TO BASEBALL FIELD AND ADJACENT AREAS.

APPROXIMATE LOCATION OF NEW IRRIGATION SYSTEM SHOWN BY DASHED IMPROVEMENTS TO EXISTING IRRIGATION SYSTEM.
 AREAS OF PROPOSED IRRIGATION ARE TO BE LIMITED TO BASEBALL FIELD AND ADJACENT AREAS.

APPROXIMATE LOCATION OF NEW IRRIGATION SYSTEM SHOWN BY DASHED IMPROVEMENTS TO EXISTING IRRIGATION SYSTEM.
 AREAS OF PROPOSED IRRIGATION ARE TO BE LIMITED TO BASEBALL FIELD AND ADJACENT AREAS.

APPROXIMATE LOCATION OF NEW IRRIGATION SYSTEM SHOWN BY DASHED IMPROVEMENTS TO EXISTING IRRIGATION SYSTEM.
 AREAS OF PROPOSED IRRIGATION ARE TO BE LIMITED TO BASEBALL FIELD AND ADJACENT AREAS.

NOT TO SCALE

GENERAL NOTES AND SPECIFICATIONS
 IF ANY CONDITIONS ARISE DURING CONSTRUCTION THAT PRECLUDE COMPLIANCE WITH THE DETAILS SHOWN ON THESE DRAWINGS, THE WORK IN THE AFFECTED AREAS SHALL CEASE AND THE ENGINEER SHALL BE NOTIFIED IMMEDIATELY.

CONCRETE AND REINFORCING NOTES
 ALL CONCRETE SHALL HAVE A MINIMUM 28 DAY COMPRESSIVE STRENGTH OF 4,000 PSI AND SHALL BE NORMAL WEIGHT. CONCRETE MIX SHALL HAVE 6% - 8% ENTRAINED AIR.
 ANY PROPOSED CONSTRUCTION JOINT LOCATIONS SHALL BE APPROVED BY THE ENGINEER.
 PREFORMED EXPANSION JOINT FILLER TO BE USED AT ALL EXPANSION JOINTS. JOINT SEALER SHALL BE APPLIED ALONG THE FRONT FACE OF WALL UNLESS OTHERWISE NOTED. COLOR OF SEALER TO BE DETERMINED BY OWNER.
 REINFORCING SHALL CONFORM TO ASTM A618, GRADE 60 AND WELDED WIRE FABRIC SHALL CONFORM TO ASTM A186.
 THE BOTTOM OF ALL FOOTINGS SHALL BE A MINIMUM OF 3'-4" BELOW FINISHED GRADE. FOOTINGS SHALL BEAR ON COMPACTED GRANULAR FILL.
 ALL TIES TO BE CAST INTO THE CONCRETE SUCH AS REINFORCING, SLEEVES, DOWELS, WALL MOUNTED POSTS, ETC. SHALL BE SECURELY POSITIONED IN THE FORMS ACCORDING TO ACI 301, LATEST EDITION BEFORE PLACING CONCRETE REINFORCING COVER: 2" AT BOTTOM OF FOOTINGS; 2" ELSEWHERE UNLESS NOTED OTHERWISE.

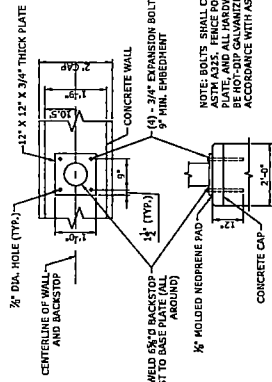

BACKSTOP POST ANCHORAGE
 SCALE: 3/4" = 1'-0"

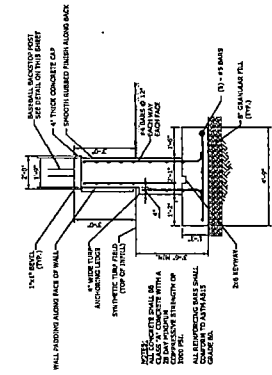

TYPICAL SECTION - RAISED WALL W/ BACKSTOP
 SCALE: 3/4" = 1'-0"

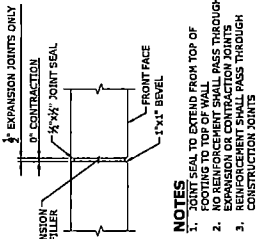

EXPANSION AND CONTRACTION JOINT DETAIL
 NOT TO SCALE

- NOTES**
1. JOINT SEAL TO EXTEND FROM TOP OF FOOTING TO TOP OF WALL.
 2. EXPANSION JOINT DETAIL SHALL BE IDENTICAL TO THE DETAIL SHOWN ON THIS DRAWING.
 3. REINFORCEMENT SHALL PASS THROUGH CONSTRUCTION JOINTS.

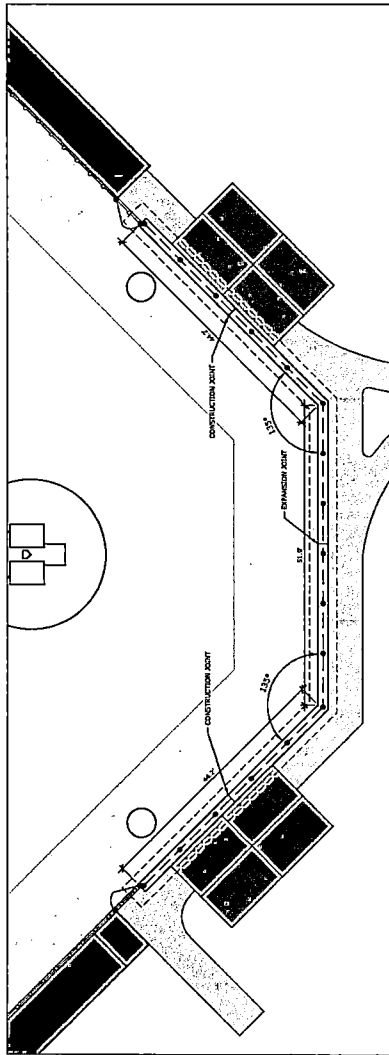

PLAN - WALL AT BASEBALL FIELD WITH CHAIN LINK BACKSTOP
 SCALE: 1" = 10'

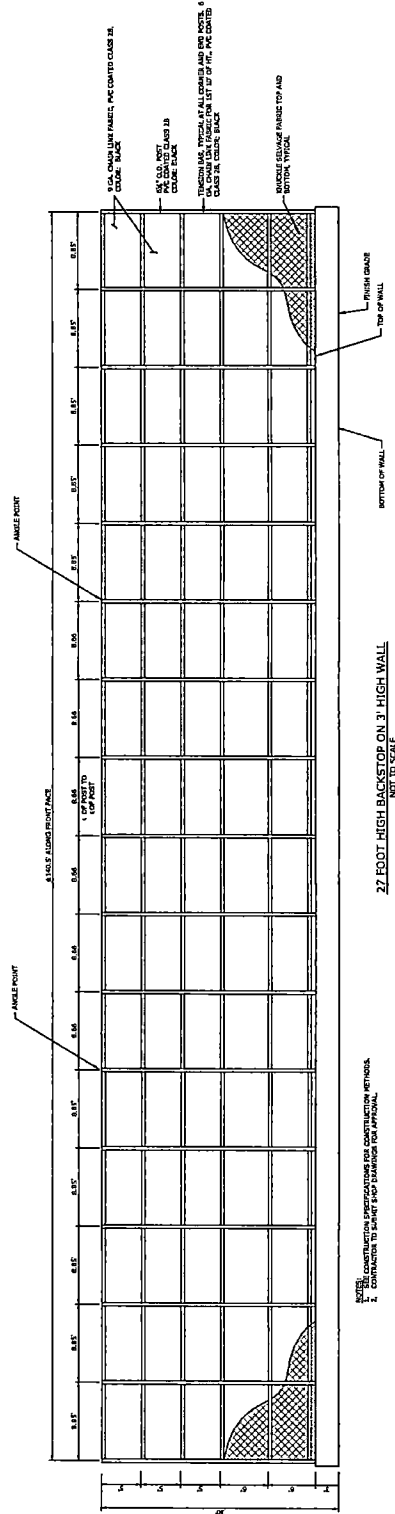

- NOTES**
1. CONSTRUCTION TO MAINTAIN AND INSURE PROPER ALIGNMENT NETWORK.

**27 FOOT HIGH BACKSTOP ON 3\"/>
 NOT TO SCALE**

CEP	DATE	DESCRIPTION

SITE DETAILS
 UNIVERSITY OF IMPROVEMENTS
 BASEBALL FIELD IMPROVEMENTS
 SOUND VIEW DRIVE
 BRIDGEPORT, CONNECTICUT

SD-4

DATE: AUGUST 16, 2017

PROJECT NO: 2016-02

AS NOTED

UNIVERSITY OF IMPROVEMENTS

MILONE & MACBROOM
 99 Ruddy Drive
 Chelsea, Connecticut 06019
 (203) 712-1234 FAX (203) 712-2733
 www.miloneandmacbroom.com

DATE	DESCRIPTION

SITE DETAILS
 UNIVERSITY OF BRIDGPORT
 BASERAL FIELD IMPROVEMENTS
 SOUND VIEW DRIVE
 BRIDGPORT, CONNECTICUT

CER: MUR
 DATE: 08/20/2017
 SCALE: AS NOTED
 DRAWING NO.: 2103-02

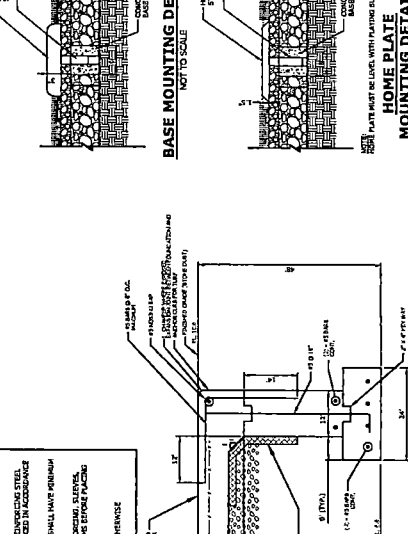
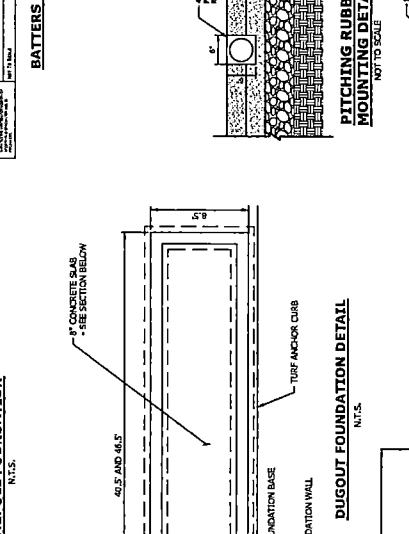
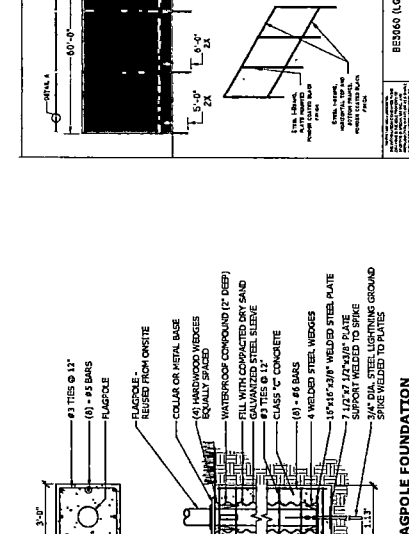
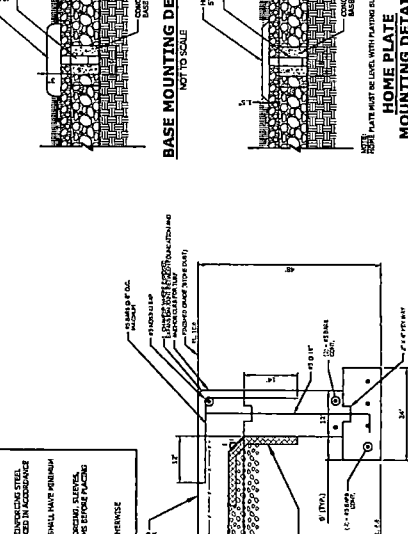
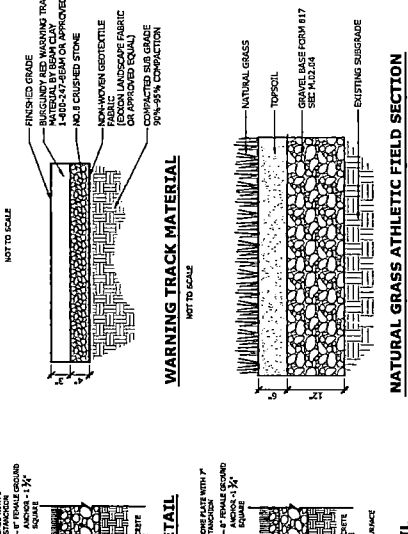
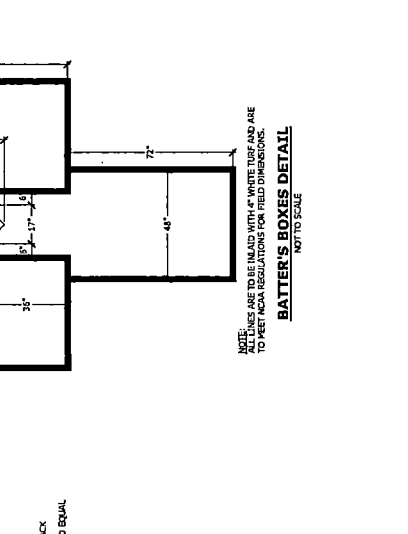
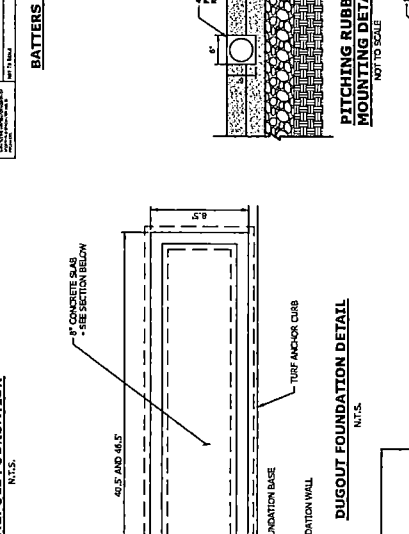
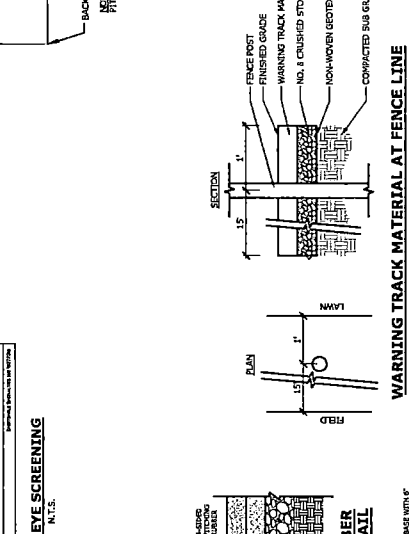
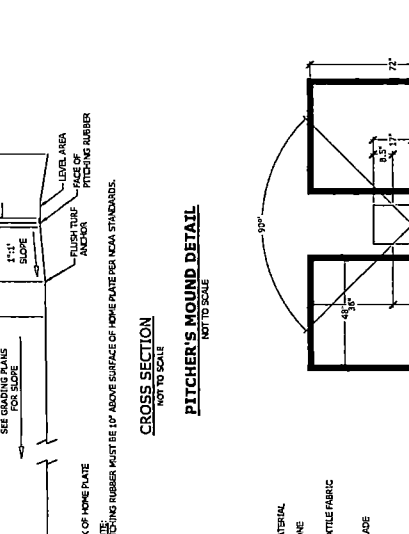
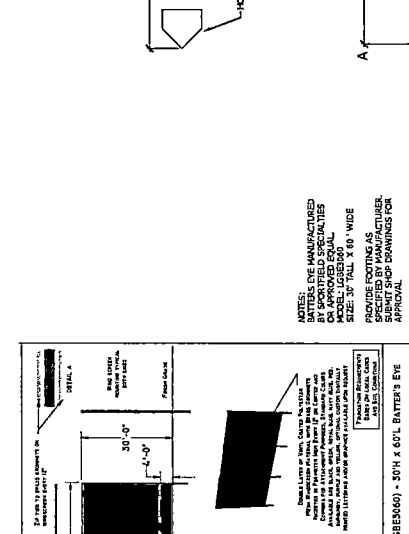
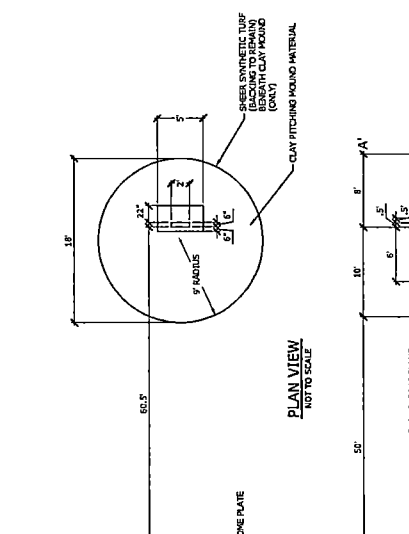

REINFORCED CONCRETE NOTES
 CLASS 'C' CONCRETE FOR ALL WALLS AND FOOTINGS
 ALL WALLS AND FOOTINGS SHALL BE CONFINED AND SHALL BE REINFORCED IN ACCORDANCE WITH ACI 318, LATEST EDITION.
 ALL TIES TO BE CAST INTO THE CONCRETE SUCH AS SCHEDULED, SUPPLY, CONCRETE, ETC. SHALL BE SECURELY POSITIONED IN THE FORMS BEFORE PLACING REINFORCING CONCRETE.
 1\"/>

UNIVERSITY OF BRIDGPORT
 BASERAL FIELD IMPROVEMENTS
 SOUND VIEW DRIVE
 BRIDGPORT, CONNECTICUT

CER: MUR
 DATE: 08/20/2017
 SCALE: AS NOTED
 DRAWING NO.: 2103-02

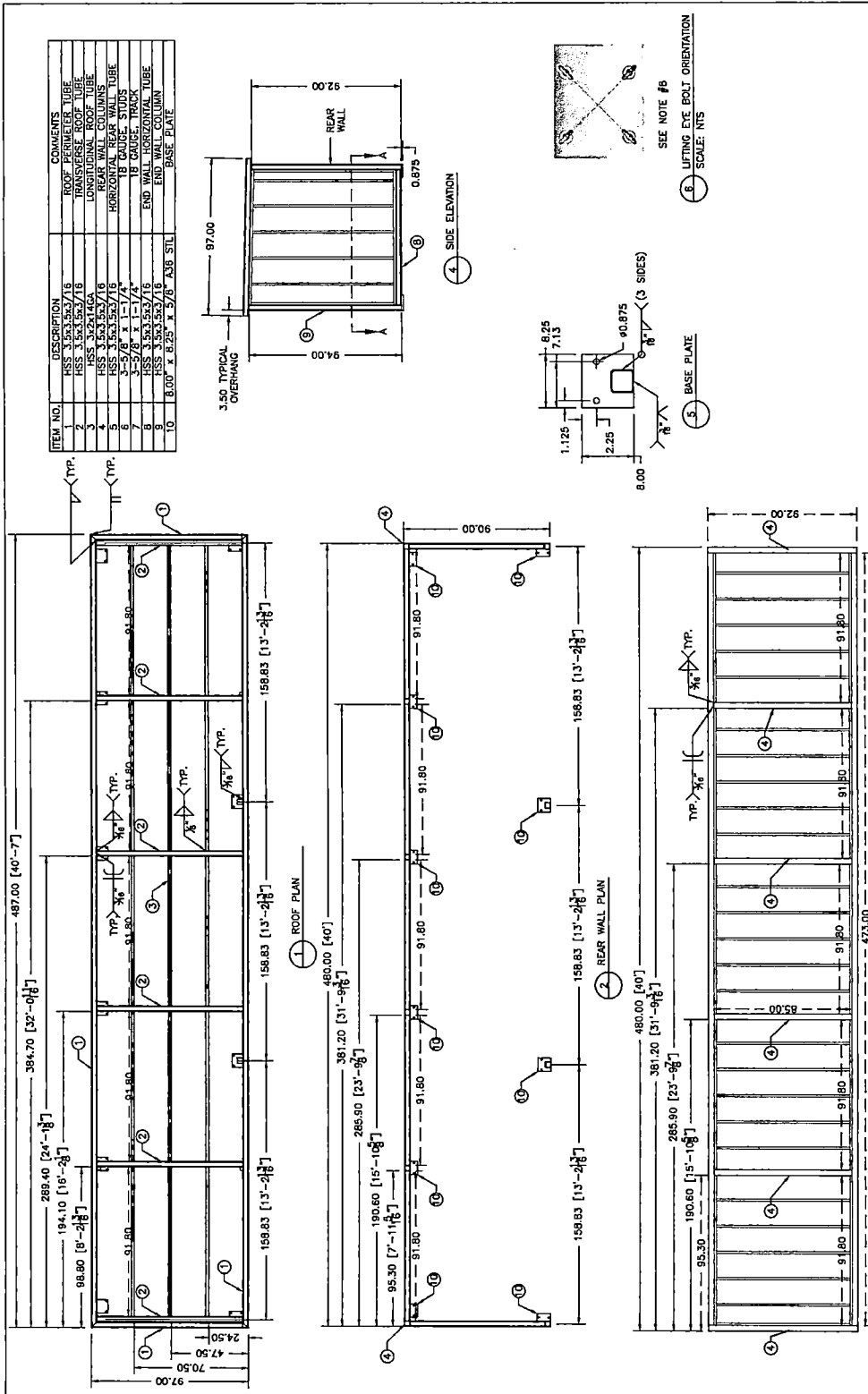

ITEM NO.	DESCRIPTION	QUANTITY	COMMENTS
1	HSS 3.5x3.5x3/16	18	ROOF PERIMETER TUBE
2	HSS 3.5x3.5x3/16	18	TRANSVERSE ROOF TUBE
3	HSS 3.5x3.5x3/16	18	LONGITUDINAL ROOF TUBE
4	HSS 3.5x3.5x3/16	18	REAR WALL COLUMNS
5	HSS 3.5x3.5x3/16	18	ROOF STUDS
6	HSS 3.5x3.5x3/16	18	ROOF GAUGE STUDS
7	HSS 3.5x3.5x3/16	18	ROOF TRACK
8	HSS 3.5x3.5x3/16	18	END WALL HORIZONTAL TUBE
9	HSS 3.5x3.5x3/16	18	END WALL COLUMN
10	8.00 x 6.25 x 3/8 A36 STL	18	BASE PLATE

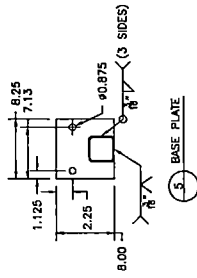
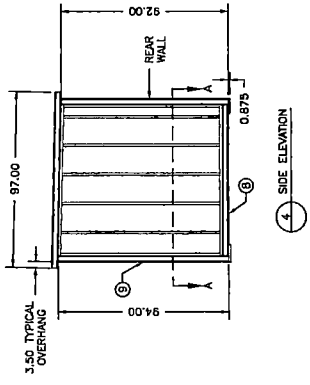

DIMENSIONS ARE IN INCHES		NAME	DATE
TOLERANCES	FRACTIONAL ±	CS	9/16/17
TWO PLACE DECIMAL ±	THREE PLACE DECIMAL ±	CS	
MATERIAL	FINISH	CS	
NEXT ASSTY USED IN	APPLICATION	CS	
<p>THE INFORMATION CONTAINED IN THIS DRAWING IS THE PROPERTY OF SPORTSFIELD SPECIALTIES, INC. ANY REPRODUCTION IN PART OR AS A WHOLE WITHOUT THE WRITTEN PERMISSION OF SPORTSFIELD SPECIALTIES, INC. IS PROHIBITED.</p>		CS	
<p>NOTES:</p> <ol style="list-style-type: none"> THE 20 GA CLASSIC RIB ROOF DECKING IS NOT SHOWN FOR CLARITY. THE ROOF SLOPES DOWN 2" FROM FRONT COLUMN TO REAR WALL. ALL COLUMNS, L.I.N.G., SHALL BE WELDED ALL AROUND WITH 3/8" FILLET AND FLARE BEVEL WELDS TO THE ROOF AND BASE TUBES. SCREWS @ 16" O.C. TO BEAM STUD FASTENED TO TRACK WITH #7 x 7/16" SELF DRILLING PAN HEAD SCREWS USE (2) #5/8" HILTI HAS ROPS (PER BASE PLATE) WITH HILTI HIT-HY 200 ADHESIVE. MAINTAIN 7-1/2" EMBEDMENT AND AT LEAST 10" EDGE DISTANCE. 		CS	
<p>SPORTSFIELD SPECIALTIES, INC.</p>		CS	
<p>8x40 EDO NO CLOSET</p>		CS	
<p>Submittal</p>		CS	
<p>CONSTRUCTION</p>		CS	
SIZE (PG. NO.)	DATE	REV.	
B	9/16/17		

CITY OF BRIDGEPORT
OFFICE OF THE CITY ATTORNEY

CITY ATTORNEY
R. Christopher Meyer

999 Broad Street
Bridgeport, Connecticut 06604-4328

DEPUTY CITY ATTORNEY
John P. Bohannon, Jr.

ASSISTANT CITY ATTORNEYS
Eroll V. Skyers
Tamara J. Titre

ASSOCIATE CITY ATTORNEYS

Mark T. Anastasi
Richard G. Kascak, Jr.
Bruce L. Levin
John R. Mitola
Lawrence A. Ouellette, Jr.
Tyisha S. Toms
Lisa R. Trachtenburg



OF COUNSEL
Russell Liskov
Ronald J. Pacacha

Telephone (203) 576-7647
Facsimile (203) 576- 8252

The City Council
of the City of Bridgeport
c/o Lydia Martinez, City Clerk
45 Lyon Terrace
Bridgeport, CT 06604

September 26, 2017

Re: Appointment Letter for Fire Chief Richard Thode

Dear City Clerk Martinez:

Kindly place the above-referenced matter on the agenda for the Monday, October 2, 2017 meeting for Referral to the Contracts Committee.

Attached is a DRAFT of the proposed Appointment Letter, which is being submitted to the City Council, for its approval specifically as regards the provision set forth in the final sentence of the fourth from last paragraph (relating to the City's annual contribution to the ICMA Retirement System Plan) on behalf of Chief Thode.

While the granting of this pension benefit requires City Council approval, it should be noted that this provision is wholly consistent with those benefits granted to prior Bridgeport fire and police chiefs. Labor Relations Director Janene Hawkins and I will attend the Contracts Committee meeting on Wednesday, October 11th to present this proposed document for the Administration.

Thank you very much for your assistance in this matter.

Very truly yours,



Mark T. Anastasi
Assoc. City Atty.

Cc: Mayor Joseph P. Ganim
Frances Ortiz, Asst. City Clerk
Richard Thode, Fire Chief
R. Christopher Meyer, City Attorney
Daniel Shamas, Chief of Staff
Kimberly Staley, CAO
Janene Hawkins, Labor Relations Dir.

RECEIVED
CITY CLERKS OFFICE
17 SEP 29 AM 9:29
ATTEST
CITY CLERK

DRAFT

October 20, 2017

Richard Thode, Fire Chief
Bridgeport Fire Department
30 Congress Street
Bridgeport, CT 06604

RE: Appointment to the Position of Fire Chief

Dear Chief Thode:

I am writing to memorialize that on Friday, February 24, 2017 in my capacity as Mayor and pursuant to the authority vested in me under Bridgeport City Charter, Chapter 17, 4 (b) (7), I appointed you as Fire Chief for the City of Bridgeport, Connecticut ("City") to serve a five (5) year term commencing that same date.

The position of Fire Chief is not affiliated with any collective bargaining unit; and in accordance with Bridgeport Code of Ordinances § 2.36.010 *Officers' Salaries* your initial annual salary for this appointment was set initially at \$135,000; to be increased to the top of the ordinance salary range for the position; that is, one-hundred forty-five thousand, four-hundred and twenty-eight dollars (\$145,428) effective as of July 1, 2017. In addition, during the term of your appointment you are entitled to all increases for cost of living as provided for in Ordinance § 2.36.010. Fire Chief is a bona fide executive position. Therefore, you are exempt from entitlement to any overtime pay and are not eligible for compensatory time either to be used for leave or to be accumulated and paid out upon separation from service.

As Fire Chief, you are subject to and shall abide by, all pertinent state and federal statutes and regulations, as well as City charter and code of ordinances and City and departmental official policies, procedures, rules and regulations. As a twenty (20) plus hour per week employee, you are entitled to receive the standard employee benefits granted to the City's unaffiliated class. Included in this benefits package are the following:

- longevity pay at the rate of \$75 per years of service (to be calculated based upon your initial hiring date with the City's Fire Department);
- vacation, sick, personal, holiday and bereavement leave time in accordance with those provided to other unaffiliated employees of the City;

- health benefits insurance coverage and a term life insurance policy in accordance with those provided to other unaffiliated employees of the City and their spouses and dependents; and short-term/long-term disability insurance in accordance with the City's Policy on Unaffiliated Employee Sick Leave.

It is my understanding you will be continuing as a contributing member of the CT Municipal Employees Retirement Fund ("CMERS"), with both you and the City continuing to make their respective required contributions. In addition, you will continue to be eligible to participate in the City's 457 Deferred Compensation Plan in the same manner as other City employees. Finally, the City will contribute ten percent (10%) of your annual salary to the ICMA Retirement System Plan; and you will be eligible to make additional contributions to the ICMA Plan as consistent with the plan rules and applicable law.

You will be provided with an appropriate take-home motor vehicle in accordance with the City Owned Vehicle Policy; as well as fire-fighting and foul weather gear; and shall receive nine-hundred and twenty-five dollars (\$925) annually as a uniform allowance.

My administration looks forward to continuing to work with you and the outstanding Fire Fighters under your command in building upon the past success of the Bridgeport Fire Department. With your experience, qualifications and proven leadership, I am confident that together we will further improve operational efficiency and enhance public safety, with the goal of providing optimal twenty-first century fire safety services to our entire community.

I pledge my Administration's continued full support and cooperation in partnering with you and the brave and dedicated Fire Fighters under your command. Congratulations and Best Wishes!

Sincerely,

Joseph P. Ganim, Mayor

cc: Honorable Bridgeport City Council
Lydia Martinez, City Clerk
Board of Fire Commissioners
R. Christopher Meyer, City Attorney
Daniel Shamas, Chief of Staff
Kimberly Staley, CAO
Janene Hawkins, Labor Relations Dir.
David Dunn, Civil Service Personnel Dir.
Mark T. Anastasi, Assoc. City Atty.



JOSEPH P. GANIM
Mayor

OFFICE OF THE MAYOR
CITY OF BRIDGEPORT, CONNECTICUT
999 BROAD STREET
BRIDGEPORT, CONNECTICUT 06604
TELEPHONE (203) 576-7201
FAX (203) 576-3913

**Comm. #152-16 Ref'd to Miscellaneous Matters Committee
On 10/02/2017**

MEMORANDUM

TO: Lydia Martinez, City Clerk

FROM: Joseph P. Ganim, Mayor

DATE: September 29, 2017

SUBJECT: BOARDS AND COMMISSIONS

Please place the following names listed below on the October 2, 2017 City Council Agenda for referral to the Miscellaneous Matters Committee for the purpose of appointment to the Bridgeport Environmental Task Force, as in accordance with Section 2.124.030 of the Bridgeport Code of Ordinances.

- Jack O. Banta
- Kathleen Donovan
- Sharon Lewis
- Alma Maya
- Josh Parrow
- Nicholas Roussas

Thanks.

JPG/mr

RECEIVED
CITY CLERKS OFFICE
17 SEP 29 PM 2:40
ATTEST
CITY CLERK

MEETING DATE: October 2, 2017 NO. 152-16

COMMITTEE: Miscellaneous Matters Committee REFERRED TO COMM.:

SUBJECT: Appointment of Jack O. Banta to the Bridgeport Environmental Task Force.

MOTION BY: T McCarthy 2ND BY: A. Paoletto

APPROVED _____ DENIED _____ TABLED _____ REF. TO COMM. _____

REMARKS:

Request to Withdrawl item for referral

	YES	NO
Kathryn M. Bukovsky		
Scott Burns		
Jack O. Banta		
Denese Taylor-Moye		
M. Evette Brantley		
John W. Olson		
Thomas C. McCarthy		
Jeanette Herron		
Michelle A. Lyons		
AmyMarie Vizzo-Paniccia		
Mary A. McBride-Lee		
Richard D. Salter, Sr.		
Jose Casco		
Alfredo Castillo		
Aidee Nieves		
Milta I. Feliciano		
Anthony R. Paoletto		
Nessah J. Smith		
Eneida L. Martinez		
James Holloway		

ATTEST
CITY CLERK
17 OCT -3 AM 10:14
RECEIVED
CITY CLERKS OFFICE



JOSEPH P. GANIM
Mayor

OFFICE OF THE MAYOR
CITY OF BRIDGEPORT, CONNECTICUT
999 BROAD STREET
BRIDGEPORT, CONNECTICUT 06604
TELEPHONE (203) 576-7204
FAX (203) 576-3913

**Comm. #153-16 Ref'd to Miscellaneous Matters Committee
On 10/02/2017**

MEMORANDUM

TO: Lydia Martinez, City Clerk

FROM: Joseph P. Ganim, Mayor

DATE: September 29, 2017

SUBJECT: BOARDS AND COMMISSIONS

Please place the following names listed below on the October 2, 2017 City Council Agenda for referral to the Miscellaneous Matters Committee for the purpose of appointment to the Bridgeport Environmental Task Force, as in accordance with Section 2.124.030 of the Bridgeport Code of Ordinances.

- Jack O. Banta
- Kathleen Donovan
- Sharon Lewis
- Alma Maya
- Josh Parrow
- Nicholas Roussas

Thanks.

JPG/mr

RECEIVED
CITY CLERKS OFFICE
17 SEP 29 PM 2:40
ATTEST
CITY CLERK



JOSEPH P. GANIM
Mayor

OFFICE OF THE MAYOR
CITY OF BRIDGEPORT, CONNECTICUT
999 BROAD STREET
BRIDGEPORT, CONNECTICUT 06604
TELEPHONE (203) 576-7201
FAX (203) 576-3913

**Comm. #154-16 Ref'd to Miscellaneous Matters Committee
On 10/02/2017**

MEMORANDUM

TO: Lydia Martinez, City Clerk

FROM: Joseph P. Ganim, Mayor

DATE: September 29, 2017

SUBJECT: BOARDS AND COMMISSIONS

Please place the following names listed below on the October 2, 2017 City Council Agenda for referral to the Miscellaneous Matters Committee for the purpose of appointment to the Bridgeport Environmental Task Force, as in accordance with Section 2.124.030 of the Bridgeport Code of Ordinances.

- Jack O. Banta
- Kathleen Donovan
- Sharon Lewis
- Alma Maya
- Josh Parrow
- Nicholas Roussas

Thanks.

JPG/mr

ATTEST
CITY CLERK _____

RECEIVED
CITY CLERKS OFFICE
17 SEP 29 PM 2:40



JOSEPH P. GANIM
Mayor

OFFICE OF THE MAYOR
CITY OF BRIDGEPORT, CONNECTICUT
999 BROAD STREET
BRIDGEPORT, CONNECTICUT 06601
TELEPHONE (203) 576-7201
FAX (203) 576-3913

**Comm. #155-16 Ref'd to Miscellaneous Matters Committee
On 10/02/2017**

MEMORANDUM

TO: Lydia Martinez, City Clerk

FROM: Joseph P. Ganim, Mayor

DATE: September 29, 2017

SUBJECT: BOARDS AND COMMISSIONS

Please place the following names listed below on the October 2, 2017 City Council Agenda for referral to the Miscellaneous Matters Committee for the purpose of appointment to the Bridgeport Environmental Task Force, as in accordance with Section 2.124.030 of the Bridgeport Code of Ordinances.

- Jack O. Banta
- Kathleen Donovan
- Sharon Lewis
- Alma Maya
- Josh Parrow
- Nicholas Roussas

Thanks.

JPG/mr

ATTEST
CITY CLERK
RECEIVED
CITY CLERKS OFFICE
17 SEP 29 PM 2:40



JOSEPH P. GANIM
Mayor

OFFICE OF THE MAYOR
CITY OF BRIDGEPORT, CONNECTICUT
999 BROAD STREET
BRIDGEPORT, CONNECTICUT 06604
TELEPHONE (203) 576-7201
FAX (203) 576-3913

**Comm. #156-16 Ref'd to Miscellaneous Matters Committee
On 10/02/2017**

MEMORANDUM

TO: Lydia Martinez, City Clerk

FROM: Joseph P. Ganim, Mayor

DATE: September 29, 2017

SUBJECT: BOARDS AND COMMISSIONS

Please place the following names listed below on the October 2, 2017 City Council Agenda for referral to the Miscellaneous Matters Committee for the purpose of appointment to the Bridgeport Environmental Task Force, as in accordance with Section 2.124.030 of the Bridgeport Code of Ordinances.

- Jack O. Banta
- Kathleen Donovan
- Sharon Lewis
- Alma Maya
- Josh Parrow
- Nicholas Roussas

Thanks.

JPG/mr

RECEIVED
CITY CLERKS OFFICE
17 SEP 29 PM 2:40
ATTEST
CITY CLERK



JOSEPH P. GANIM
Mayor

OFFICE OF THE MAYOR
CITY OF BRIDGEPORT, CONNECTICUT
999 BROAD STREET
BRIDGEPORT, CONNECTICUT 06604
TELEPHONE (203) 576-7201
FAX (203) 576-3913

**Comm. #157-16 Ref'd to Miscellaneous Matters Committee
On 10/02/2017**

MEMORANDUM

TO: Lydia Martinez, City Clerk

FROM: Joseph P. Ganim, Mayor

DATE: September 29, 2017

SUBJECT: BOARDS AND COMMISSIONS

Please place the following names listed below on the October 2, 2017 City Council Agenda for referral to the Miscellaneous Matters Committee for the purpose of appointment to the Bridgeport Environmental Task Force, as in accordance with Section 2.124.030 of the Bridgeport Code of Ordinances.

- Jack O. Banta
- Kathleen Donovan
- Sharon Lewis
- Alma Maya
- Josh Parrow
- Nicholas Roussas

Thanks.

JPG/mr

ATTEST
CITY CLERK
RECEIVED
CITY CLERKS OFFICE
17 SEP 29 PM 2:40

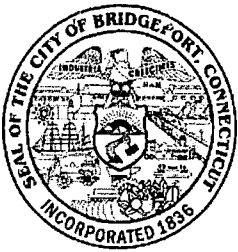

OFFICE OF THE CITY CLERK RESOLUTION FORM

ATTEST
CITY CLERK
17 SEP 2017
PM 2:16
RECEIVED
CITY CLERK'S OFFICE

SECTION I CITY COUNCIL SUBMISSION INFORMATION

Log ID/Item Number:	147-16
Submitted by Councilmember(s):	Mary A. McBride-Lee
Co-Sponsors(s):	Choose an item. Choose an item. Choose an item. Choose an item.
District:	135TH
Subject:	Honorary Street Naming portion of Platt Street for Rev. William Barber Sr.
Referred to:	Public Safety and Transportation Committee
City Council Date:	October 2, 2017

SECTION II RESOLUTION (PLEASE TYPE BELOW)

WHEREAS, Reverend William Barber Sr. was a man who dedicated and consecrated his life to God and the founder of the "Mother Church" Mt. Sinai Baptist Church located at 500 Platt Street; and

WHEREAS, the Mt. Sinai Baptist Church sits at the corner of Platt Street and Platt Place, along a relatively straight portion of Platt Street that runs from Chopsey Hill Road to Ryon Street; and

WHEREAS, it was because of Reverend Barber Sr.'s work, commitment, support and love for the people in the community that the church was first founded in April of 1949 on Valley Avenue; and

WHEREAS, later a neighbor on Platt Street gave Reverend Barber Sr. a parcel of land at 500 Platt Street for one dollar to build an edifice that is now the celebrated Mt. Sinai Baptist Church; and

WHEREAS, historically the Mt. Sinai Baptist Church has the distinction of being the first and only African American Church in the City of Bridgeport, Connecticut to be built mortgage free; and

WHEREAS, it is because of Reverend William Barber Sr.'s vision and ministry that the "Mother Church" Mt. Sinai Baptist Church at 500 Platt Street has become the icon that it is today; and

WHEREAS, it would be befitting to a man that made an enormous impact on the lives of his family, parishioners, and this community be honored by the City Council as a builder, one that fed the hungry, helped the poor and imparted good news of the gospel of Jesus Christ to all mankind; and

NOW THEREFORE, BE IT RESOLVED to honor the memory of Reverend William Barber Sr. we come together and designate Platt Street, from Chopsey Hill Road to Ryon Street, as "**Reverend William Barber Sr. Way**" with street signs bearing that designation being placed on the current corner street signs at the intersection of Platt Street with Chopsey Hill Road, Platt Place and Ryon Street.

(Attachments)

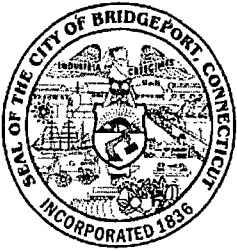

OFFICE OF THE CITY CLERK RESOLUTION FORM

SECTION III SUBSEQUENT REFERRALS/REPLIES AND DATE SENT/RECEIVED

DEPARTMENT	Referral date sent	Response Received	Date reply received
Choose an item.		<input type="checkbox"/> Yes <input type="checkbox"/> No	
Choose an item.		<input type="checkbox"/> Yes <input type="checkbox"/> No	
Choose an item.		<input type="checkbox"/> Yes <input type="checkbox"/> No	
Choose an item.		<input type="checkbox"/> Yes <input type="checkbox"/> No	
Choose an item.		<input type="checkbox"/> Yes <input type="checkbox"/> No	
Choose an item.		<input type="checkbox"/> Yes <input type="checkbox"/> No	
Choose an item.		<input type="checkbox"/> Yes <input type="checkbox"/> No	
Choose an item.		<input type="checkbox"/> Yes <input type="checkbox"/> No	

SECTION IV PUBLIC HEARING INFORMATION

Public Hearing Required	Details	Date
<input type="checkbox"/> Yes <input type="checkbox"/> No	Public Hearing Ordered on:	
	CT Post Publication Date(s):	
	Public Hearing Held on:	

SECTION V AMENDMENTS/EXHIBITS

Choose an item.	<input type="checkbox"/> Yes <input type="checkbox"/> No	Date:
-----------------	--	-------

SECTION VI COMMITTEE ACTION/APPROVAL INFORMATION

Choose an item.	<input type="checkbox"/> Yes <input type="checkbox"/> No	Date:
Choose an item.	<input type="checkbox"/> Yes <input type="checkbox"/> No	Date:
Choose an item.	<input type="checkbox"/> Yes <input type="checkbox"/> No	Date:

SECTION VII WITHDRAWN/SINE DIE INFORMATION

Choose an item.	<input type="checkbox"/> Yes <input type="checkbox"/> No	Date:
-----------------	--	-------

SECTION VIII DATE OF APPROVAL/DENIAL FROM CITY COUNCIL

City Council Approval Date: _____

SECTION IX COMMENTS (if any)



Google

Paul's Fish & Chips



File Edit View Favorites Tools Help

MSN.com - Hotmail Out... Home - Team Site (2) Home - Team Site IT Security Threats Syma... Risks - Symantec Corp

500 Platt St. Google Maps

Page Safety Tools

100%

Imagens ©2017 DigitalGlobe, New York GIS, USDA, Farm Service Agency, Map data ©2017 Google, United States, 3D Earth view: it not available, Terrain, Street View, ©1998-2017

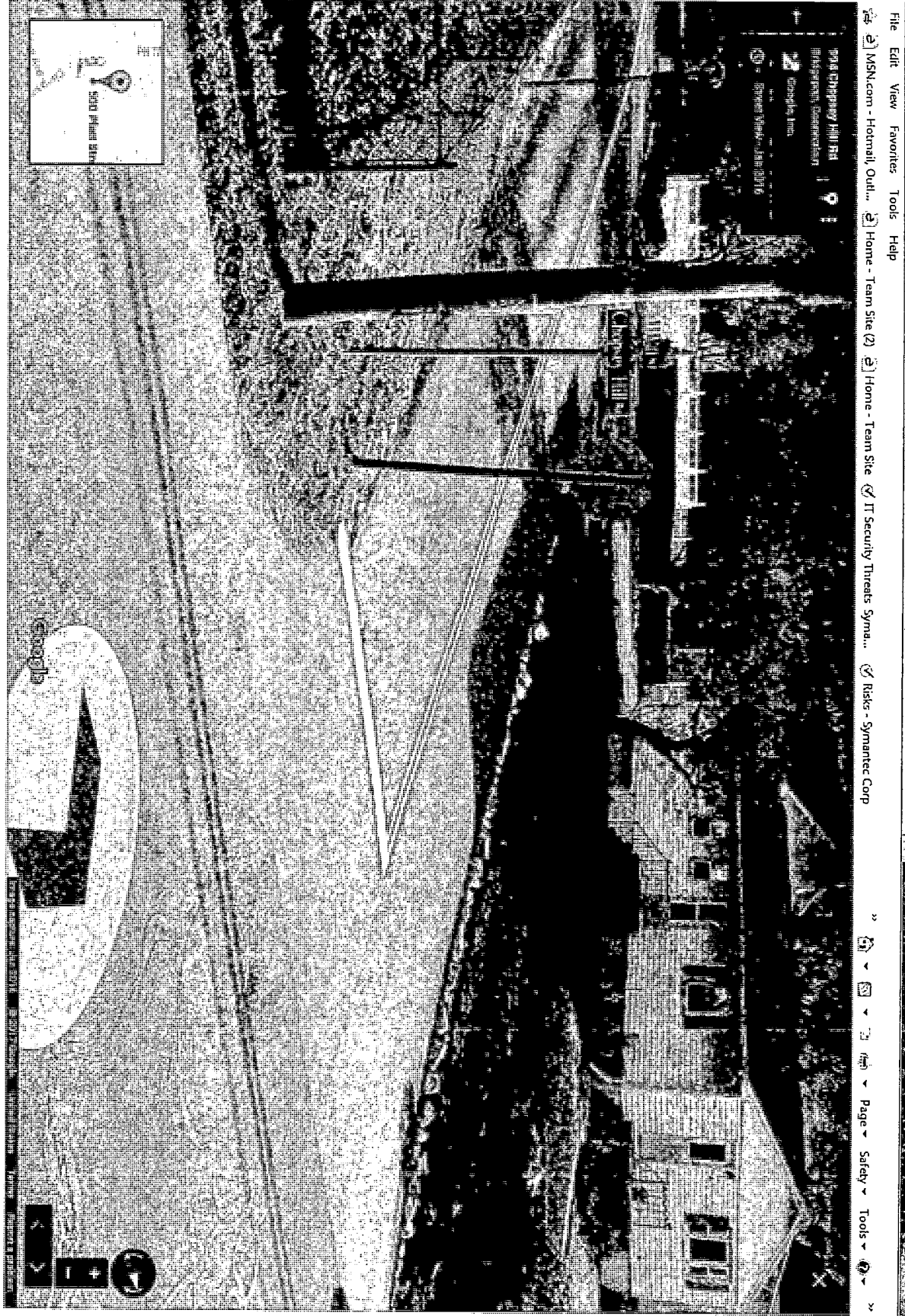

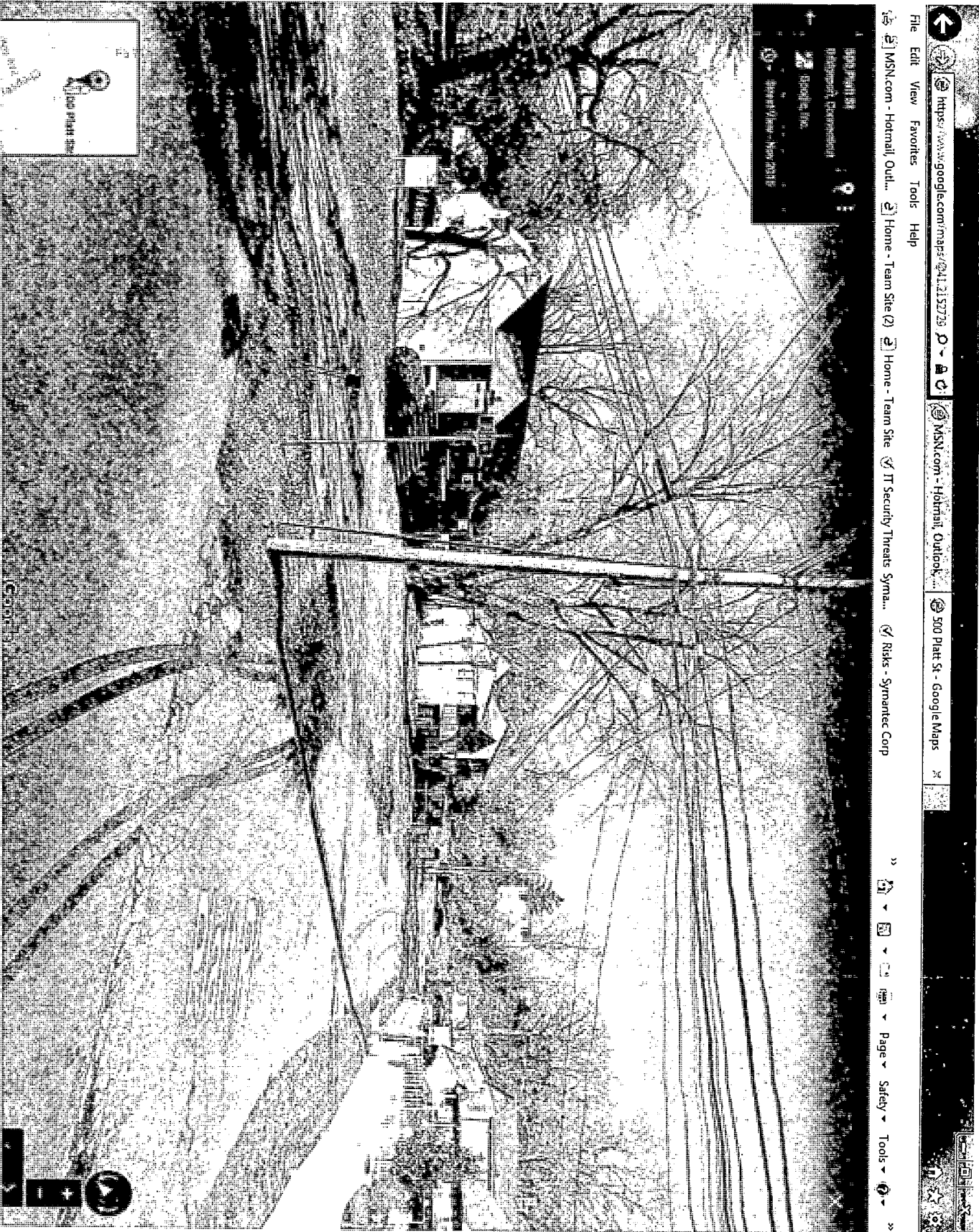

File Edit View Favorites Tools Help
https://www.google.com/maps/@41.2152729, 500 Platt St - Google Maps
MSN.com - Hotmail, Outlook, IT Security Threats Syma...
Risks - Symantec Corp

Home - Team Site (2) Home - Team Site IT Security Threats Syma...
Risks - Symantec Corp
Page Safety Tools

Navigation and search controls including a search bar with the text 'Where do you want to go?' and a search button.

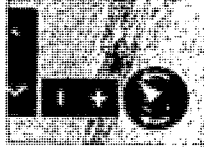
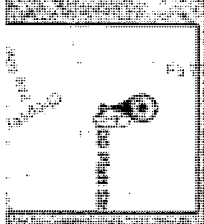

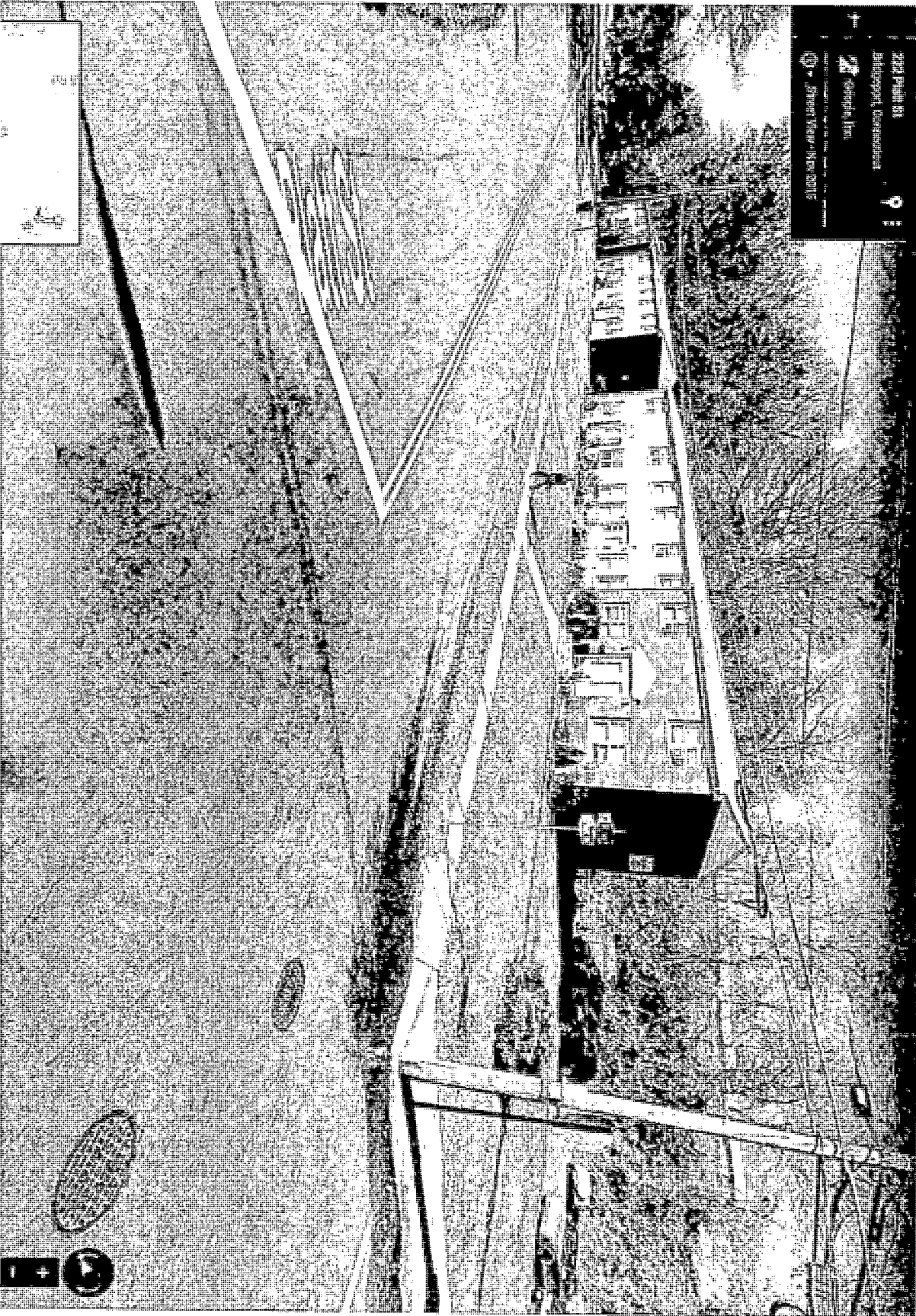

https://www.google.com/maps/@41.2165327, 89.0111111, 15z

MSN.com - Hotmail, Outlook

222 Platt St - Google Maps



File Edit View Favorites Tools Help

MSN.com - Hotmail, Outlook Home - Team Site (2) Home - Team Site IT Security Threats Syma... Risks - Symantec Corp

» Page Safety Tools

222 Platt St

Philadelphia, Pennsylvania

Philadelphia, Pa.

Street View - MSN 2015

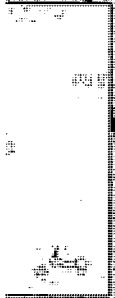



City of Bridgeport, Connecticut

Office of the City Clerk

To the City Council of the City of Bridgeport:

The Committee on Ordinances begs leave to report; and recommends for adoption the following resolution:

Item No. *71-16 Consent Calendar

WHEREAS, the City Charter of the City of Bridgeport, Chapter 2 – Officers and Elections, requires that all officers of the city, elected or appointed under the provisions of the charter, shall be residents and registered voters of the City of Bridgeport; and

WHEREAS, there have been allegations raised as to the residency of elected officials in the city in the immediate past; and

WHEREAS, there has been a lapse in the re-appointment of board and/or commission members in recent years, with no re-verification of residency; and

WHEREAS, it is important to city residents to trust that each elected or appointed officer of the city resides in the city or appropriate district during their entire term of office or service; and

WHEREAS, such information is regularly provided to the public by comparable Connecticut municipalities; Now Therefore,

BE IT ORDAINED: By the City Council of the City of Bridgeport that the Bridgeport Municipal Code of Ordinances, Chapter 2.02 – Administrative Regulations Generally, is hereby amended to add new Section 2.02.080 – Residency reporting of all municipal elected officials, board and commission members as follows:

(NEW)

2.02.080 Residency reporting of all municipal elected officials, board and commission members.

All municipal elected officers, as well as board and commission members (mayoral-appointed or otherwise), are required to provide their current residence street address of record to the town clerk's office by January 31st of each year of service. Any change of residence address during service as an elected officer or board member must be reported to the town clerk's office within 30 days of such residency change.

Failure to abide by section 2.02.080 by an elected official may result in the filing of a formal complaint by the town clerk to the Connecticut State Elections Enforcement Commission.



City of Bridgeport, Connecticut Office of the City Clerk

Report of Committee on Ordinances
Item No. *71-16 Consent Calendar

-2-

Failure to abide by section 2.02.080 by a board or commission member (mayoral-appointed or otherwise) may result in referral to the Mayor and City Council for removal pursuant to the Charter of the City of Bridgeport, Section 17. – Removal of Certain Officers.

Exceptions to this section may be made at the discretion of the City Attorney's Office when public disclosure of the current residence street address of record of an elected official or a board or commission member (mayoral-appointed or otherwise) poses a proven risk of significant danger to the elected official, board or commission member.

RESPECTFULLY SUBMITTED,
THE COMMITTEE ON
ORDINANCES

City Council Date: ~~June 5, 2017~~, Tabled by Full Council and Ref'd back to Committee on: June 5, 2017 Resubmitted on: ~~October 2, 2017~~, Tabled by Full Council and Ref'd back to Committee on: October 2, 2017



City of Bridgeport, Connecticut

Office of the City Clerk

To the City Council of the City of Bridgeport.

The Committee on Ordinances begs leave to report; and recommends for adoption the following resolution:

Item No. *128-16 Consent Calendar

BE IT ORDAINED: By the City Council of the City of Bridgeport that the Bridgeport Municipal Code of Ordinances, Chapter 3.70 – Event Admissions Surcharge, is hereby amended to add new Section 3.70.015 – Exemption, as follows:

Sections:

3.70.010 - Imposition of surcharge.

There is hereby imposed a surcharge of five percent of the admission charge to any place of amusement, entertainment or recreation within the City of Bridgeport, as defined in subsection (3) of Section 12-540 of the Connecticut General Statutes, except when the admissions charge is not more than ten dollars (\$10.00). The amount of any such surcharge shall be in addition to any tax otherwise applicable to such admission charge, except that no surcharge shall be imposed on a facility if (1) there is imposed a surcharge on such facility pursuant to Connecticut General Statutes Section 12-579, or (2) all of the proceeds from the event inure exclusively to an entity which is exempt from federal income tax under the Internal Revenue Code, provided such entity actively engages in and assumes the financial risk associated with the presentation of such event.

The surcharge shall be imposed on the facility at which such event takes place, and reimbursement for the surcharge shall be collected from the purchaser upon payment of the admission charge. The surcharge, when added to the admission charge, shall be a debt from the purchaser to the facility and shall be recoverable at law. The facility shall remit the total amount of all surcharges imposed pursuant to this section to the Tax Collector in accordance with Connecticut General Statutes Section 12-581. Any surcharge imposed shall be subject to the provisions of Connecticut General Statutes Chapter 226a in the same manner as a tax imposed pursuant to said chapter.

(Ord. dated 11/7/16)



City of Bridgeport, Connecticut

Office of the City Clerk

Report of Committee on Ordinances
Item No. *128-16 Consent Calendar

-2-

(NEW)

3.70.015 - Exemption.

Notwithstanding the forgoing, the Klein Auditorium (910 Fairfield Avenue) and Downtown Cabaret (263 Golden Hill Street) are hereby expressly exempt from such surcharge on the basis on their status as 501-c-3 non-profit organizations.

3.70.020 - Enforcement.

This chapter shall be administered by the tax collector of the city of Bridgeport. All forms necessary or convenient for the enforcement of this chapter shall be prescribed, printed, and furnished by the tax collector. The tax collector shall enforce all rules and regulations adopted by the state tax commissioner relating to the administration and enforcement of this chapter.

(Ord. dated 11/7/16)

3.70.030 - Filing return.

Each person subject to a surcharge imposed under this section shall file a return on or before the twentieth of each month setting forth the amount of surcharge due for the preceding month and such additional information as the tax collector may require. Payment of such surcharge shall accompany each return. Any person subject to such surcharge failing to file a return and pay the surcharge when due is liable for a penalty of ten dollars (\$10.00), or ten percent of the surcharge due, whichever is greater. In addition, there shall be added interest at the rate of one and one-half percent per month from the date of the return until date of payment. The tax collector, if satisfied that the failure to comply with any provision of this section was due to reasonable cause, may abate or remit the whole or part of any penalty.

(Ord. dated 11/7/16)

3.70.040 - Appeals.

Any taxpayer aggrieved because of any order, decision, determination or disallowance of the tax collector under the provisions of this chapter may, within one month after service upon the taxpayer of notice of such order, decision, determination or disallowance, take an appeal there from to the superior court for the judicial district in which such municipality is located, which shall be accompanied by a citation to such tax collector to appear before such court. Such citation shall be signed by the same authority, and such appeal shall be returnable at the same time and served and



City of Bridgeport, Connecticut

Office of the City Clerk

Report of Committee on Ordinances
Item No. *128-16 Consent Calendar

-3-

returned in the same manner as is required in case of summons in a civil action. Such appeals shall be preferred cases to be heard, unless, cause appears to the contrary, at the first session by the court or by a committee appointed by it. The court may grant such relief as may be equitable and, if such tax has been paid prior to the granting of such relief, may order the city to pay the amount of such relief, with interest at the rate of six percent per annum, to the aggrieved taxpayer. If the appeal has been taken without probable cause, the court may tax double or triple costs, as the case demands; and, upon all such appeals which may be denied, costs may be taxed against the appellant at the discretion of the court, but no costs shall be taxed against the city.

(Ord. dated 11/7/16)

3.70.050 - State law adopted.

The provisions of Public Act No. 16-3, Sec. 186, as may be amended from time to time, are incorporated in this chapter and made a part hereof.

(Ord. dated 11/7/16)

3.70.060 - Effective date.

The provisions of this ordinance shall take effect starting on January 1, 2017.

(Ord. dated 11/7/16)



City of Bridgeport, Connecticut Office of the City Clerk

Report of Committee on Ordinances
Item No. *128-16 Consent Calendar

-4-

RESPECTFULLY SUBMITTED,
THE COMMITTEE ON
ORDINANCES

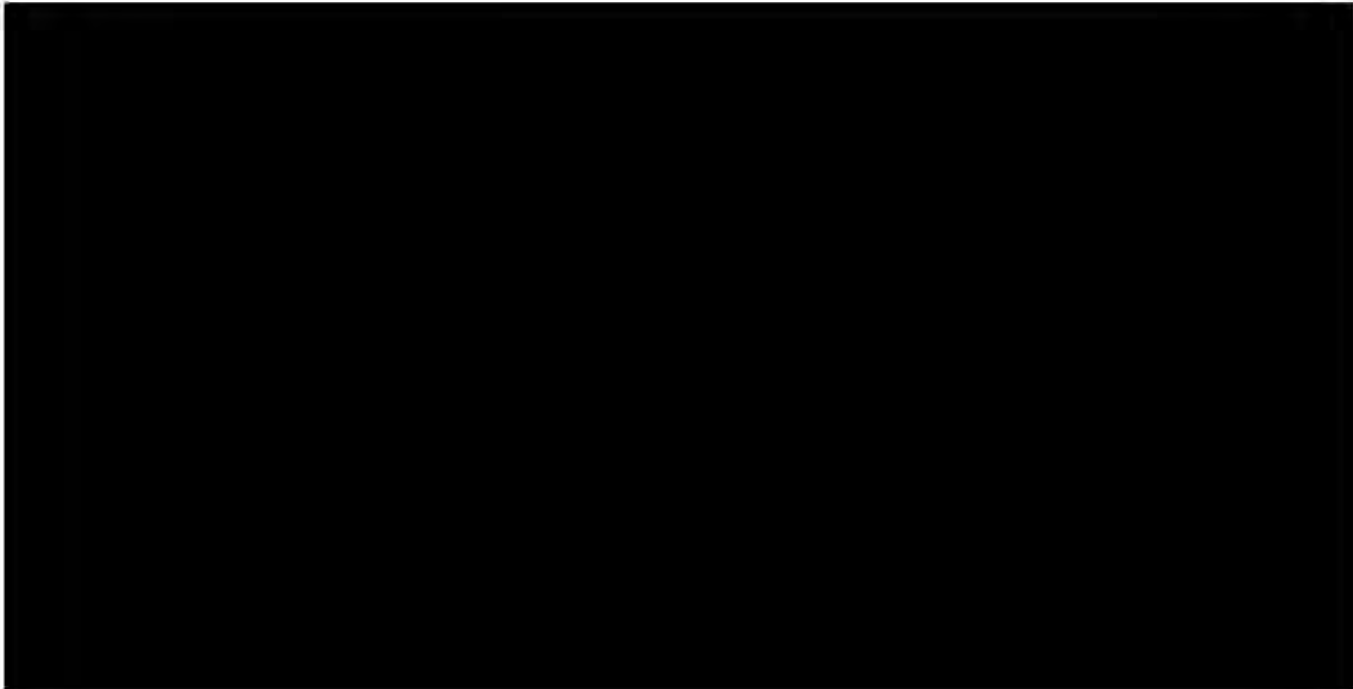

*City Council Date: ~~October 2, 2017~~, Tabled by Full Council and Ref'd back to Committee on:
October 2, 2017*

Item# *131-16 Consent Calendar

Amendments to the Municipal Code of Ordinances,
Title 8 – Health and Safety, amend Chapter 8.88 –
Municipal Clinics.



Report
of
Committee
on

Ordinances

City Council Meeting Date: October 2, 2017

Attest: *Lydia N. Martinez*
Lydia N. Martinez, City Clerk

Approved by: *Joseph P. Canim*
Joseph P. Canim, Mayor

Date Signed: *10/19/17*

RECEIVED
CITY CLERKS OFFICE
17 OCT 20 AM 11:52
ATTEST
CITY CLERK



City of Bridgeport, Connecticut

Office of the City Clerk

To the City Council of the City of Bridgeport:

The Committee on Ordinances begs leave to report; and recommends for adoption the following resolution:

Item No. *131-16 Consent Calendar

WHEREAS, the City of Bridgeport's current Chapter 8.88 of the Bridgeport Municipal Code of Ordinances has been in effect and unamended since 1992; and

WHEREAS, the City has decided to clarify and simplify the Chapter on Municipal Clinics to better comport with certain state requirements; Now, Therefore,

BE IT HEREBY ORDAINED: By the City Council of the City of Bridgeport that the current Chapter 8.88 of the Bridgeport Municipal Code be amended as per the new Chapter 8.88 as attached hereto, and be effective upon publication:

Chapter 8.88 - MUNICIPAL CLINICS

Sections: 8.88.010 - Board of governors – Composition – Terms.

There shall continue to be a public dispensary known as the municipal clinics of the city, which shall be under the management, direction and control of a board of governors of ~~eight~~ **five** members, ~~at least six of whom shall be physicians~~ **medical professionals** ~~who have engaged in the actual practice of their profession in the city for a period of at least three years.~~ The members of such board shall occupy their office during good behavior, ~~and such board shall fill any vacancy which shall occur in their membership by death, resignation or removal.~~ **All appointments shall be made by the mayor subject to the approval of the city council. Members shall be electors of the city holding no salaried municipal office.** ~~The director of health and social services and the superintendent of the department of public welfare shall be ex officio members of such board.~~ **The members of the board shall have the right to vote, with the exception of the director of health and social services, who shall serve ex officio. The director of public health and social services may designate a person to serve in his or her absence.**

Members of the board of governors shall be appointed for terms of three years, except that of those first appointed, one shall be appointed for a term ending December 31, 2017, two for a term ending December 31, 2018 and two for a term ending December 31, 2019. Vacancies shall be filled for the unexpired term in the same manner as the original appointment.

(Ord. dated 12/21/92 § 75(h); prior code § 14-49)



City of Bridgeport, Connecticut

Office of the City Clerk

Report of Committee on Ordinances
Item No. *131-16 Consent Calendar

-2-

8.88.020 - Board of governors - Officers.

The board of governors of the municipal clinics shall annually elect from its members a president and a secretary. It shall be the duty of the secretary to keep an accurate record of the proceedings of the board.

(Prior code § 14-50)

8.88.030 - Board of governors, Clinic Administrator - Duties.

~~The board of governors of the municipal clinics shall maintain and conduct the emergency hospital and such outpatient clinics as it may determine and in accordance with state laws and regulations governing licensed outpatient clinics operated by municipalities. The activities of the board, except as to emergency work, shall be confined to the dependent and semidependent classes of the city and shall include the assumption of the duties imposed upon selectment by statute relative to the medical treatment of paupers insofar as such treatment may be provided within such clinics. Such board shall cooperate with the department of health and social services in the physical and mental examination of such other persons as may be agreed upon by such boards.~~

The board of governors, as a minimum, shall: (1) Adoption of bylaws or their equivalent, rules and regulations or their equivalent, including medical staff bylaws, or both; (2) annual appointment of the medical staff with annual designation of medical director; and (3) appointment of a clinic administrator, qualified on the basis of training and experience approved by the commissioner of public health.

The clinic administrator, or the equivalent, shall be responsible to the governing board for the management and operation of the clinic and for the employment of personnel. The administrator shall attend meetings of the governing board and meetings of the professional staff.

Personnel shall be employed in sufficient numbers and of adequate qualifications so that the function of the clinic may be performed efficiently.

(Ord. dated 12/21/92 § 75(g); prior code § 14-51)



City of Bridgeport, Connecticut

Office of the City Clerk

Report of Committee on Ordinances
Item No. *131-16 Consent Calendar

-3-

~~8.88.040—Board of governors—Assistance by board of public welfare.~~

~~The board of public welfare shall lend all assistance to the board of governors of the municipal clinics when possible and shall provide such material relief in food, diets, fuel and rent as may be necessary in the judgment of the board of governors to supplement its medical and social treatment to the end that practical benefit to patients may be effected; provided, however, that nothing in this section shall obligate the board of public welfare to furnish aid to any individual not legally entitled thereto.~~

REPEAL

(Prior code § 14-52)

8.88.040 – Professional Staff.

There shall be an organized professional staff of not fewer than three members of the major profession or professions providing care in the clinic. The professional staff shall adopt written rules and regulations governing its own activities, subject to approval of the governing board of the clinic. As a minimum these shall include:

- (1) methods of control of privileges granted to members of the medical staff and the responsibilities of the medical director;**
- (2) method of professional supervision of clinical work;**
- (3) provision for regular staff meetings;**
- (4) preparation of adequate case records; and**
- (5) procedure for recommending appointment to the staff and for hearing complaints regarding the conduct of members, referring the same, with recommendations, to the governing board.**

8.88.050 - Construction of chapter.

Nothing in this chapter shall be construed so as to conflict with the powers and duties of the department of health and social services or the board of public welfare as defined by the statutes of the state and the charter of the city, and the board of governors of the municipal clinics shall strictly comply with the authorized rules and regulations of the department of health and services.

(Ord. dated 12/21/92 § 75(g); prior code § 14-53)



City of Bridgeport, Connecticut

Office of the City Clerk

Report of Committee on Ordinances
Item No. *131-16 Consent Calendar

-4-

~~8.88.060—H. Philip Dinan Evaluation Center.~~

~~The authority for the administration of the services of the H. Philip Dinan Evaluation Center shall be transferred from the department of health and social services to the board of education.~~

~~(Ord. dated 12/21/92 § 75(g); prior code § 14-54)~~

~~[Effective Upon Publication]~~

RESPECTFULLY SUBMITTED,
THE COMMITTEE ON
ORDINANCES

Eneida L. Martinez, D-139th, Co-Chair

Jose R. Casco, D-136th, Co-Chair

Michelle A. Lyons, D-134th

Mary McBride-Lee, D-135th

Kathryn M. Bukovsky, D-130th

Jack O. Banta, D-131st

Richard D. Salter, Sr., D-135th

City Council Date: October 2, 2017

Item# *100-16 Consent Calendar

Disposition of Certain City Owned properties (11)
within the Seaview Avenue Industrial Park.



Report
of
Committee
on

CEQD and Environment

City Council Meeting Date: October 2, 2017

Attest: *Lydia N. Martinez*
Lydia N. Martinez, City Clerk

Approved by: *[Signature]*
Joseph J. Ganim, Mayor

Date Signed: _____

RECEIVED
CITY CLERKS OFFICE
17 OCT 20 AM 11:52
ATTEST
CITY CLERK



City of Bridgeport, Connecticut

Office of the City Clerk

To the City Council of the City of Bridgeport.

The Committee on Economic and Community Development and Environment begs leave to report; and recommends for adoption the following resolution:

Item No. *100-16 Consent Calendar

Amendment 8/15/17

A Resolution by the Bridgeport City Council Authorizing the Disposition of Eleven Properties within the Seaview Avenue Industrial Park

WHEREAS, pursuant to a series of resolutions passed on 10/4/1999, 10/16/2000, 4/2/2001, and 6/21/2004, the Bridgeport City Council has authorized the following specific actions:

The Approval of the Municipal Development Plan for the East Side/East End Area in and around the area bounded by Seaview Avenue, Crescent Avenue, Central Avenue and Williston Street (the "MDP");

The Designation of the Bridgeport Economic Development Corporation ("BEDCO") as the City's Development Agency for implementing all project activities within the MDP area, including the securing of funding, the planning and development of real property improvements, the acquisition and sale of real property for purposes of industrial and commercial retention and expansion, and the remediation of environmentally damaged properties all in a manner consistent with Connecticut General Statutes Chapter 132 of Title 8, governing the implementation of Municipal Development Projects;

The Development of the Seaview Avenue Industrial Park (the "SAIP") as the central project activity within the MDP Area, with the specific goal of fostering commercial and industrial growth within the MDP;

The Discontinuance of streets within the MDP in support of the development of the SAIP; and

WHEREAS in accordance with guidance from the City Attorney's Office, and in furtherance of the stated purposes of the MDP, BEDCO issued a Request for Expressions of Developer Interest, a process through which it ultimately identified two companies that had been referred by the City's Office of Planning and Economic Development: Architectural Door Corporation and WC McBride Electrical Contractors, LLC.; and



City of Bridgeport, Connecticut

Office of the City Clerk

Report of Committee on **ECD and Environment**
Item No. *100-16 Consent Calendar

-2-

WHEREAS, BEDCO has requested that the City's Office of Planning and Economic Development ("OPED") seek City Council authorization to allow BEDCO to re-subdivide and sell the following eleven (11) properties: 430 Bunnell Street; 440 Bunnell Street; 448 Bunnell Street; 454 Bunnell Street; 1209 Central Avenue; 1217 Central Avenue; 1231 Central Avenue; 1239 Central Avenue; 1251 Central Avenue; 1271 Central Avenue, and 169 Williston Street (the "Properties"); and

WHEREAS, as part of the implementation of the MDP, these Properties were acquired, cleared and environmentally remediated where necessary; and

WHEREAS the Properties comprise approximately 1.8 acres, and are proposed for sale at the appraisal-derived price of \$270,000, with the proceeds from such sale to remain with BEDCO in support of its continued activities in implementing the MDP and the SAIP, including property re-subdivision, environmental compliance, and demolition, as governed by State of Connecticut Department of Economic Development Assistance Agreements and Budgets relevant to the use of sales proceeds, and all as consistent with BEDCO's obligations as the City's Designated Development Agent for the MDP; and

WHEREAS, the City's Office of Planning and Economic Development ("OPED") wishes to see the Properties move into private ownership, developed, and become tax-producing.

NOW THEREFORE BE IT RESOLVED, that the Director of OPED or his Designee is authorized, in a manner consistent with the purposes expressed in this resolution, to take all necessary actions and to do any and all necessary and appropriate things in furtherance of the objectives of this resolution.

BE IT FURTHER RESOLVED that BEDCO is authorized as the City's Development Agency for the MDP to sell the Properties in a manner consistent with the purposes expressed in this resolution.



City of Bridgeport, Connecticut
Office of the City Clerk

Report of Committee on **ECD and Environment**
Item No. *100-16 Consent Calendar

-3-

RESPECTFULLY SUBMITTED,
THE COMMITTEE ON
ECONOMIC AND COMMUNITY DEVELOPMENT AND ENVIRONMENT

Milta I. Feliciano, D-137th, Co-Chair

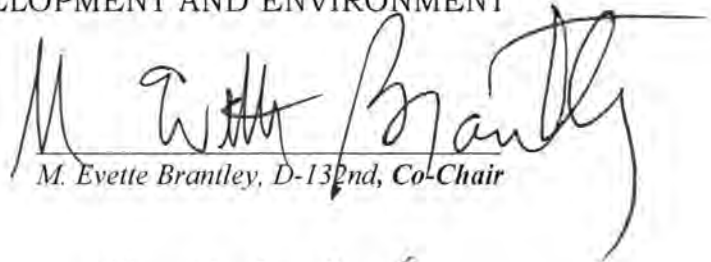
M. Evette Brantley, D-132nd, Co-Chair

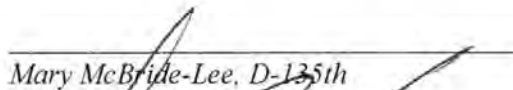
Mary McBride-Lee, D-135th

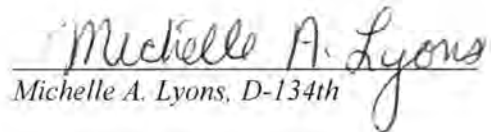
Michelle A. Lyons, D-134th

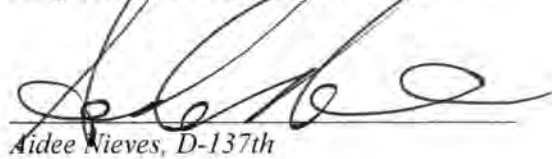
Aidee Nieves, D-137th

Eneida L. Martinez, D-139th

Jeanette Herron, D-133rd

City Council Date: October 2, 2017

Item# *110-16 Consent Calendar

Settlement of Pending Litigation with Constance L. Taaffe.



Report
of
Committee
on

Miscellaneous Matters

City Council Meeting Date: October 2, 2017

Attest: *Lydia N. Martinez*
Lydia N. Martinez, City Clerk

Approved by: _____
Joseph P. Scanlon
Joseph P. Scanlon, Mayor

Date Signed: _____

RECEIVED
CITY CLERKS OFFICE
17 OCT 20 AM 11:52

ATTEST
CITY CLERK



City of Bridgeport, Connecticut

Office of the City Clerk

To the City Council of the City of Bridgeport:

The Committee on Miscellaneous Matters begs leave to report; and recommends for adoption the following resolution:

Item No. *110-16 Consent Calendar

WHEREAS, a lawsuit in the following name was filed against the City of Bridgeport and/or its employees and investigation disclosed the likelihood on the part of the City for which, in the event of suit and trial, the City might be held liable, and

WHEREAS, negotiations with the Plaintiff's attorney has made it possible to settle this suit for the figure set forth below, and the City Attorney, therefore, recommends the following settlement be accepted, Now, Therefore be it

RESOLVED, That the Comptroller be, and hereby is authorized, empowered and directed to draw his order on the City Treasurer payable as follows:

<u>NAME</u>	<u>ATTORNEY</u>	<u>NATURE of CLAIM</u>	<u>SETTLEMENT</u>
Constance L. Taaffe	Owens, Schine & Nicola 799 Silver Lane Trumbull, CT 06611	Personal Injury	\$25,750.00

BE IT FURTHER RESOLVED, that the amount set forth as above are paid to the Plaintiff's attorney in full payment, settlement, release and discharge of all rights and cause of action described in the suit instituted by the above mentioned Plaintiff against the City and known as docket numbers in the courts set forth; provided, however, that the City's draft shall not be delivered to the Plaintiff's attorneys until the City Attorney has been furnished with a full release and discharge in writing in each case, approved by the City Attorney or Deputy City Attorney.



City of Bridgeport, Connecticut

Office of the City Clerk

Report of Committee on Miscellaneous Matters
Item No. *110-16 Consent Calendar

-2-

RESPECTFULLY SUBMITTED,
THE COMMITTEE ON
MISCELLANEOUS MATTERS

AmyMarie Vizzo-Paniccia, D-134th, *Co-Chair*



Richard D. Salter, Sr., D-135th, *Co-chair*

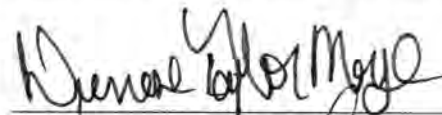

Denese Taylor-Moye, D-131st



Anthony R. Paoletto, D-138th

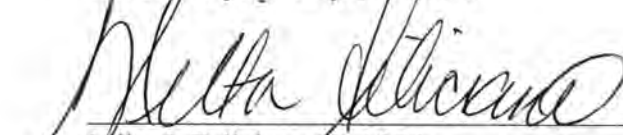

Milta I. Feliciano, D-137th

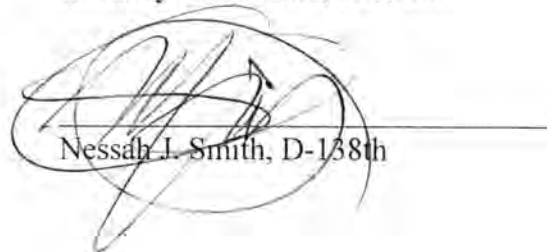

Nessah J. Smith, D-138th

John W. Olson, D-132nd

City Council Date: October 2, 2017

Item# *113-16 Consent Calendar

Refund of Excess Payments - 1700 SPE CT Park LLC.



Report
of
Committee
on

Miscellaneous Matters

City Council Meeting Date: October 2, 2017

Attest:

Lydia N. Martinez

Lydia N. Martinez, City Clerk

Approved by:

Joseph P. Panim
Joseph P. Panim, Mayor

Date Signed

10/19/17

RECEIVED
CITY CLERKS OFFICE
17 OCT 20 AM 11:53
ATTEST
CITY CLERK



City of Bridgeport, Connecticut

Office of the City Clerk

To the City Council of the City of Bridgeport.

The Committee on Miscellaneous Matters begs leave to report; and recommends for adoption the following resolution:

Item No. *113-16 Consent Calendar

BE IT RESOLVED, That the Comptroller be, and hereby is authorized, empowered and directed to draw his warrants on the City Treasurer in favor of the following named person and for the amount set opposite said name, all in accordance with the recommendation of the Tax Collector.

<u>Name & Address</u>	<u>Reason</u>	<u>Refund</u>
1700 SPE CT Park LLC 109 Spencer Place Re: 1011-01A 1700 Park Ave 1728	12-129	\$10,557.30

RESPECTFULLY SUBMITTED,
THE COMMITTEE ON
MISCELLANEOUS MATTERS

AmyMarie Vizzo-Paniccia, D-134th, *Co-Chair*

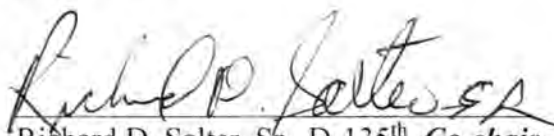
Richard D. Salter, Sr., D-135th, *Co-chair*

Denese Taylor-Moye, D-131st

Anthony R. Paolotto, D-138th

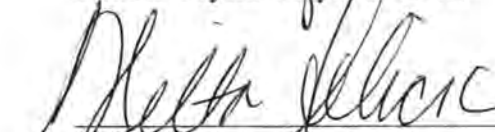
Milta I. Feliciano, D-137th

Nessah J. Smith, D-138th

John W. Olson, D-132nd

City Council Date: October 2, 2017

REQUEST FOR ABATEMENT OR REFUND OF PROPERTY TAXES

Sec. 12-81(20), Sec. 12-124, 12-125, 12-126, 12-127, 12-127a, 12-128, 12-129 Rev. as Amended
 This is to certify that 1700 SPE CT PARK LLC

- has presented satisfactory proof that he/she is entitled to an exemption on the assessment list of 10/01/2015
- Sec. 12-81 (20) Servicemen Having Disability Rating.
 - Sec. 12-124 Abatement to poor.
 - Sec. 12-125 Abatement of Taxes of Corporations.
 - Sec. 12-126 Tangible Personal Property Assessed in more than one Municipality.
 - Sec. 12-127 Abatement or Refund to Blind Persons.
 - Sec. 12-127A Abatement of Taxes on Structures of Historical or Architectural Merit.
 - Sec. 12-128 Refund of Taxes Erroneously Collected from Veterans and Relatives.
 - Sec. 12-129 Refund of Excess Payments.

1700 SPE CT PARK LLC
 109 SPENCER PLACE
 MAMARONECK, NY 10543

2015-01-0004155
 1011--01A-----
 1700 PARK AV 1728



To Collector of CITY OF BRIDGEPORT State of Connecticut.

I hereby apply for abatement or refund* of such part of my tax as shall represent:

The service exemption or Sec. 12-129 Refund of Excess Payments.
 (State reason -- Cross out service exemption if it does not apply)

		Tax	Interest	Lien	Fee	Total	Overpaid Tax
Total Due	07/01/2016	129,776.30	0.00	0.00	0.00	129,776.30	
Total Paid	01/11/2017	140,333.60	0.00	0.00	0.00	140,333.60	-10,557.30 ***
Adjusted Refund		-10,557.30	0.00	0.00	0.00	10,557.30	

PLEASE READ, SIGN, AND DATE BELOW:

I am entitled to this refund because I made the payments from funds under my control, and no other party will be requesting this refund. I understand that false or deliberately misleading statements subject me to penalties for perjury and/or for obtaining money under false pretenses.

Alvaro E. Finete
 Print Name

[Signature] 2/13/17
 Signature of Taxpayer Date

COLLECTOR'S RECOMMENDATION TO THE GOVERNING BODY

To the First Selectman, or _____
 It is recommended that refund* of property taxes and interest in the amount of 10,557.30
 be made to the above-named taxpayer in accordance with the provisions of Section (s):

Sec. 12-129 Refund of Excess Payments.

DATED AT CITY OF BRIDGEPORT, CONNECTICUT THIS 12 DAY OF January 2017

[Signature]
 TAX COLLECTOR

ACTION TAKEN BY GOVERNING BODY

The First Selectman, as authorized by the Board of Selectman, or _____
 approved on the _____ day of _____ 20____. It was voted to refund
 Property Taxes and Interest amounting to \$ _____ to _____

 First Selectman

 Other Governing Body

 Clerk

**Cross out abatement or refund as required

Mail To :
 CITY OF BRIDGEPORT
 325 CONGRESS STREET

2015-01-0004155

[Handwritten Signature]

NATIONAL TAX SEARCH LLC
AGENT FOR WELLS FARGO BANK, NA
130 SOUTH JEFFERSON STREET, STE 300
CHICAGO, IL 60651
(312) 233-6440

BMO HARRIS BANK, N.A.
CHICAGO, ILLINOIS
70-1558719

12223

1/5/2017

PAY TO THE ORDER OF City of Bridgeport, Tax Collector

\$ **70,166.80

Seventy Thousand One Hundred Sixty-Six and 80/100***** DOLLARS

City of Bridgeport, Tax Collector
45 Lyon Terrace
Room 121
Bridgeport, CT 06604

MEMO Loan: 623100212 Tax Yr: 2015, Inst: 2, CTR #: 998

[Handwritten Signature]
AUTHORIZED SIGNATURE

⑈012223⑈ ⑆071915580⑆ 04⑈353⑈875⑈6⑈

Security Features Included: Details on back.

15 2015-1-0004155

8598

NATIONAL TAX SEARCH LLC
AGENT FOR WELLS FARGO BANK, NA
130 SOUTH JEFFERSON STREET, STE 300
CHICAGO, IL 60651
(312) 233-6440

BMO HARRIS BANK, N.A.
CHICAGO, ILLINOIS
70-1558719

7/14/2016

PAY TO THE ORDER OF City of Bridgeport, Tax Collector

\$ **70,166.80

Seventy Thousand One Hundred Sixty-Six and 80/100***** DOLLARS

City of Bridgeport, Tax Collector
325 Congress Street
Bridgeport, CT 06604

MEMO Loan: 623100212 Tax Yr: 2015, Inst: 1, CTR #: 957

[Handwritten Signature]
AUTHORIZED SIGNATURE

Security Features Included: Details on back.

Item# *114-16 Consent Calendar

Refund of Excess Payments – Donna Siciliano.



Report
of
Committee
on

Miscellaneous Matters

City Council Meeting Date: October 2, 2017

Attest:

Lydia N. Martinez
Lydia N. Martinez, City Clerk

Approved by:

Joseph J. Ganim
Joseph J. Ganim, Mayor

Date Signed:

RECEIVED
CITY CLERKS OFFICE
17 OCT 20 AM 11:53
ATTEST
CITY CLERK



City of Bridgeport, Connecticut

Office of the City Clerk

To the City Council of the City of Bridgeport:

The Committee on Miscellaneous Matters begs leave to report; and recommends for adoption the following resolution:

Item No. *114-16 Consent Calendar

BE IT RESOLVED, That the Comptroller be, and hereby is authorized, empowered and directed to draw his warrants on the City Treasurer in favor of the following named person and for the amount set opposite said name, all in accordance with the recommendation of the Tax Collector.

<u>Name & Address</u>	<u>Reason</u>	<u>Refund</u>
Donna D. Siciliano 175 Battery Park Drive Bridgeport, CT 06605 Re: 0134-40	12-129	\$18,755.21

RESPECTFULLY SUBMITTED,
THE COMMITTEE ON
MISCELLANEOUS MATTERS

AmyMarie Vizzo-Paniccia, D-134th, *Co-Chair*

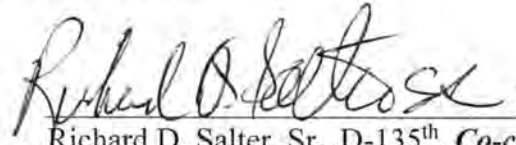

Richard D. Salter, Sr., D-135th, *Co-chair*

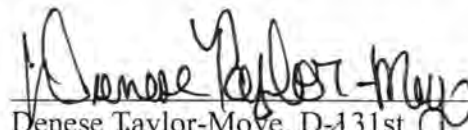

Denese Taylor-Moye, D-131st



Anthony R. Paoletto, D-138th

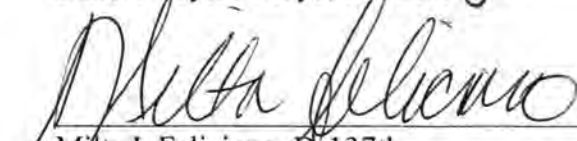

Milta I. Feliciano, D-137th



Nessah J. Smith, D-138th

John W. Olson, D-132nd

City Council Date: October 2, 2017

Sec. 12-81(20), Sec. 12-124, 12-125, 12-126, 12-127, 12-127a, 12-128, 12-129 Rev. as Amended
This is to certify that SICILIANO DONNA D

has presented satisfactory proof that he/she is entitled to an exemption on the assessment list of 10/01/2016

- Sec. 12-81 (20) Servicemen Having Disability Rating.
- Sec. 12-124 Abatement to poor.
- Sec. 12-125 Abatement of Taxes of Corporations.
- Sec. 12-126 Tangible Personal Property Assessed in more than one Municipality.
- Sec. 12-127 Abatement or Refund to Blind Persons.
- Sec. 12-127A Abatement of Taxes on Structures of Historical or Architectural Merit.
- Sec. 12-128 Refund of Taxes Erroneously Collected from Veterans and Relatives.
- Sec. 12-129 Refund of Excess Payments.

SICILIANO DONNA D
175 BATTERY PARK DR
BRIDGEPORT, CT 06605

2015-01-0027609
0134--40-----
175 BATTERY PARK DR



To Collector of CITY OF BRIDGEPORT State of Connecticut.

I hereby apply for abatement or refund* of such part of my tax as shall represent:

The service exemption or Sec. 12-129 Refund of Excess Payments.
(State reason -- Cross out service exemption if it does not apply)

		Tax	Interest	Lien	Fee	Total	Overpaid Tax
Total Due	07/01/2016	37,510.42	0.00	0.00	0.00	37,510.42	
Total Paid	01/31/2017	56,265.63	0.00	0.00	0.00	56,265.63	-18,755.21 ***
Adjusted Refund		-18,755.21	0.00	0.00	0.00	18,755.21	

PLEASE READ, SIGN, AND DATE BELOW:

I am entitled to this refund because I made the payments from funds under my control, and no other party will be requesting this refund. I understand that false or deliberately misleading statements subject me to penalties for perjury and/or for obtaining money under false pretenses.

DONNA D. SICILIANO
Print Name

Donna D. Siciliano 4/24/17
Signature of Taxpayer Date

COLLECTOR'S RECOMMENDATION TO THE GOVERNING BODY

To the First Selectman, or _____
It is recommended that refund* of property taxes and interest in the amount of 18,755.21
be made to the above-named taxpayer in accordance with the provisions of section (s):

Sec. 12-129 Refund of Excess Payments.

DATED AT CITY OF BRIDGEPORT, CONNECTICUT THIS 24 DAY OF April 2017

TAX COLLECTOR

ACTION TAKEN BY GOVERNING BODY

The First Selectman, as authorized by the Board of Selectman, or _____
approved on the _____ day of _____ 20____ It was voted to refund
Property Taxes and Interest amounting to \$ _____ to _____

File: Selectman _____
Other: Governing Body _____
City: _____

**Cross out abatement or refund as required.

Mail To :
CITY OF BRIDGEPORT
325 CONGRESS STREET
BRIDGEPORT, CT 06606

Thank you for your payment!

The City of Bridgeport Tax Collector Thanks You for your payment.

Name: Donna Siciliano
 Address: 175 Battery Park Dr., Bridgeport CT, US, 06605
 Contact: 2033684651
 Comments:

Payment ID: 29625944
 Date: 01/31/17 02:53 PM
 Subtotal: \$18755.21
 Fee: \$2.95
 Total: \$18758.16
 Method: Electronic Check(*****1543)

Item Purchased	Transaction Description	Account	Amount
Real Estate Tax	BridgeportPropTxPymt	2015010027609	\$18,755.21

Signature: _____ Date: ____/____/____
 By signing this receipt you agree to the terms and conditions of this service.

You will see one line item on your credit or debit card statement indicating the amount you paid and will be identified as *BridgeportPropTxPymt*. If you have any questions about the charges please call 1-888-891-6064.

[Print Receipt](#) [Close Window](#)

10 Bills

CELINK REVERSE MORTGAGE MORTGAGE
 C/O: INDUSTRY CONSULTING GROUP, INC.
 P.O. BOX 8265 (940) 322-5055
 WICHITA FALLS, TX 76307

East West Bank
 0096568

Date 01/25/2017 Pay Amount *****46,036.46*

Pay * FORTY SIX THOUSAND THIRTY SIX AND 46/100

VERONICA JONES
 BRIDGEPORT CITY TAX COLLECTOR
 45 LYON TERRACE RM 123
 BRIDGEPORT, CT 06604-4023

Veronica Jones

Security Features
 1-800-368-5743

⑈0096568⑈ ⑆32207038⑆ ⑆8003053926⑈

Item# *138-16 Consent Calendar

Settlement of Pending Litigation with Kyle J. Hampton.



Report
of
Committee
on

Miscellaneous Matters

City Council Meeting Date: October 2, 2017

Lydia N. Martinez

Attest:

Lydia N. Martinez, City Clerk

Approved by:

Joseph P. Ganim
Joseph P. Ganim, Mayor

Date Signed:

RECEIVED
CITY CLERKS OFFICE
17 OCT 20 AM 11:53
ATTEST
CITY CLERK



City of Bridgeport, Connecticut

Office of the City Clerk

To the City Council of the City of Bridgeport:

The Committee on Miscellaneous Matters begs leave to report and recommends for adoption the following resolution:

Item No. *138-16 Consent Calendar

WHEREAS, a lawsuit in the following name was filed against the City of Bridgeport and/or its employees and investigation disclosed the likelihood on the part of the City for which, in the event of suit and trial, the City might be held liable, and

WHEREAS, negotiations with the Plaintiff's attorney has made it possible to settle this suit for the figure set forth below, and the City Attorney, therefore, recommends the following settlement be accepted, Now, Therefore be it

RESOLVED, That the Comptroller be, and hereby is authorized, empowered and directed to draw his order on the City Treasurer payable as follows:

<u>NAME</u>	<u>ATTORNEY</u>	<u>NATURE of CLAIM</u>	<u>SETTLEMENT</u>
Kyle J. Hampton	Brendan Keefe, Esq. Lynch, Traub, Keefe & Errante P.O. Box 1612 New Haven, CT 06506	Personal Injury	\$50,000.00

BE IT FURTHER RESOLVED, that the amount set forth as above are paid to the Plaintiff's attorney in full payment, settlement, release and discharge of all rights and cause of action described in the suit instituted by the above mentioned Plaintiff against the City and known as docket numbers in the courts set forth; provided, however, that the City's draft shall not be delivered to the Plaintiff's attorneys until the City Attorney has been furnished with a full release and discharge in writing in each case, approved by the City Attorney or Deputy City Attorney.



City of Bridgeport, Connecticut
Office of the City Clerk

Report of Committee on Miscellaneous Matters
Item No. *138-16 Consent Calendar

-2-

RESPECTFULLY SUBMITTED,
THE COMMITTEE ON
MISCELLANEOUS MATTERS

AmyMarie Vizzo-Paniccia, D-134th, *Co-Chair*

Richard D. Salter, Sr., D-135th, *Co-chair*

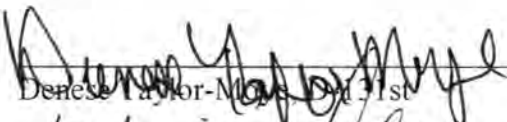
Denise Taylor-Moore, D-131st

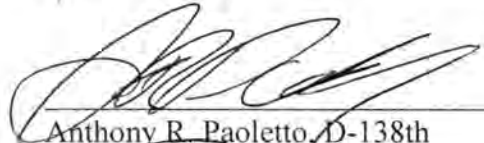
Anthony R. Paoletto, D-138th

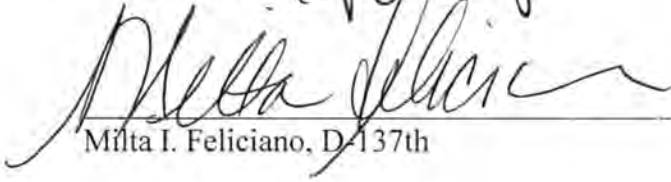
Milta I. Feliciano, D-137th

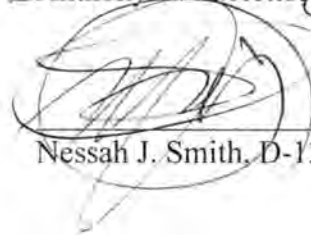
Nessah J. Smith, D-138th

John W. Olson, D-132nd

City Council Date: October 2, 2017

Item# *139-16 Consent Calendar

Settlement of Pending Litigation with Carlens and Evens Dorvelus.



Report
of
Committee
on

Miscellaneous Matters

City Council Meeting Date: October 2, 2017

Attest: *Lydia N Martinez*
Lydia N. Martinez, City Clerk

Approved by: _____
Joseph P. Ganim, Mayor

Date Signed: _____

RECEIVED
CITY CLERKS OFFICE
17 OCT 20 AM 11:53
ATTEST
CITY CLERK



City of Bridgeport, Connecticut

Office of the City Clerk

To the City Council of the City of Bridgeport.

The Committee on Miscellaneous Matters begs leave to report; and recommends for adoption the following resolution:

Item No. *139-16 Consent Calendar

WHEREAS, a lawsuit in the following name was filed against the City of Bridgeport and/or its employees and investigation disclosed the likelihood on the part of the City for which, in the event of suit and trial, the City might be held liable, and

WHEREAS, negotiations with the Plaintiff's attorney has made it possible to settle this suit for the figure set forth below, and the City Attorney, therefore, recommends the following settlement be accepted, Now, Therefore be it

RESOLVED, That the Comptroller be, and hereby is authorized, empowered and directed to draw his order on the City Treasurer payable as follows:

<u>NAME</u>	<u>ATTORNEY</u>	<u>NATURE of CLAIM</u>	<u>SETTLEMENT</u>
Carlens & Evens Dorvelus	Paul J. Ganim, Esq. 2370 Park Avenue Bridgeport, CT 06604	Motor Vehicle	\$40,000.00

BE IT FURTHER RESOLVED, that the amount set forth as above are paid to the Plaintiff's attorney in full payment, settlement, release and discharge of all rights and cause of action described in the suit instituted by the above mentioned Plaintiff against the City and known as docket numbers in the courts set forth; provided, however, that the City's draft shall not be delivered to the Plaintiff's attorneys until the City Attorney has been furnished with a full release and discharge in writing in each case, approved by the City Attorney or Deputy City Attorney.



City of Bridgeport, Connecticut
Office of the City Clerk

Report of Committee on Miscellaneous Matters
Item No. *139-16 Consent Calendar

-2-

RESPECTFULLY SUBMITTED,
THE COMMITTEE ON
MISCELLANEOUS MATTERS

AmyMarie Vizzo-Paniccia, D-134th, *Co-Chair*



Richard D. Salter, Sr., D-135th, *Co-chair*

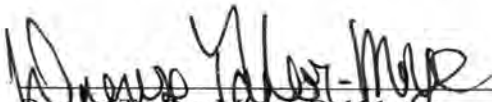

Denese Taylor-Moyle, D-131st



Anthony R. Paoletto, D-138th

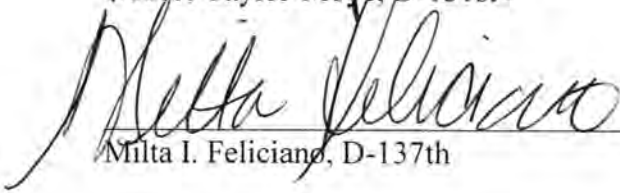

Milta I. Feliciano, D-137th



Nessah J. Smith, D-138th

John W. Olson, D-132nd

City Council Date: October 2, 2017



OFFICE OF THE CITY CLERK RESOLUTION FORM

SECTION I CITY COUNCIL SUBMISSION INFORMATION

Log ID/Item Number:	158-16			
Submitted by Councilmember(s):	Michelle A. Lyons			
Co-Sponsors(s):	Choose an item.	Choose an item.	Choose an item.	Choose an item.
District:	134TH			
Subject:	Proposed Ordinance re: Concerning Holding Landlords Accountable for Tenant Generated Noise Resulting in Complaints Filed/ Warning Process and Fines for Repeated Violations.			
Referred to:	Ordinance Committee			
City Council Date:	October 2, 2017 (OFF THE FLOOR)			

SECTION II RESOLUTION (PLEASE TYPE BELOW)

Please note: The proposed language wasn't submitted into the record and will be drafted by the City Attorney's Office per Michelle Lyons.



OFFICE OF THE CITY CLERK RESOLUTION FORM

SECTION III SUBSEQUENT REFERRALS/REPLIES AND DATE SENT/RECEIVED

DEPARTMENT	Referral date sent	Response Received	Date reply received
Choose an item. <i>City Attorney</i>	<i>10/04/2017</i>	<input type="checkbox"/> Yes <input type="checkbox"/> No	
Choose an item.		<input type="checkbox"/> Yes <input type="checkbox"/> No	
Choose an item.		<input type="checkbox"/> Yes <input type="checkbox"/> No	
Choose an item.		<input type="checkbox"/> Yes <input type="checkbox"/> No	
Choose an item.		<input type="checkbox"/> Yes <input type="checkbox"/> No	
Choose an item.		<input type="checkbox"/> Yes <input type="checkbox"/> No	
Choose an item.		<input type="checkbox"/> Yes <input type="checkbox"/> No	
Choose an item.		<input type="checkbox"/> Yes <input type="checkbox"/> No	
Choose an item.		<input type="checkbox"/> Yes <input type="checkbox"/> No	

SECTION IV PUBLIC HEARING INFORMATION

Public Hearing Required	Details	Date
<input type="checkbox"/> Yes <input type="checkbox"/> No	Public Hearing Ordered on: CT Post Publication Date(s): Public Hearing Held on:	

SECTION V AMENDMENTS/EXHIBITS

Choose an item.	<input type="checkbox"/> Yes <input type="checkbox"/> No	Date:
-----------------	--	-------

SECTION VI COMMITTEE ACTION/APPROVAL INFORMATION

Choose an item.	<input type="checkbox"/> Yes <input type="checkbox"/> No	Date:
Choose an item.	<input type="checkbox"/> Yes <input type="checkbox"/> No	Date:
Choose an item.	<input type="checkbox"/> Yes <input type="checkbox"/> No	Date:

SECTION VII WITHDRAWN/SINE DIE INFORMATION

Choose an item.	<input type="checkbox"/> Yes <input type="checkbox"/> No	Date:
-----------------	--	-------

SECTION VIII DATE OF APPROVAL/DENIAL FROM CITY COUNCIL

City Council Approval Date:

SECTION IX COMMENTS (if any)

Added from the floor

MEETING DATE: October 2, 2017

NO. 158-16

COMMITTEE:

REFERRED TO COMM.:
Ordinance Committee

SUBJECT:

Proposed Ordinance re/ Concerning Holding Landlords Accountable for tenant Generated Noise Resulting in Complaints Filed/Warning Process and Fines for repeated Violations.

MOTION BY: M. Lyons

2ND BY: M. Feliciano

APPROVED _____ DENIED _____ TABLED _____ REF. TO COMM. _____ X

REMARKS:

Motion to suspend rules to add item for referral Motion made by M. Lyons and seconded by Tom McCarthy

	YES	NO
Kathryn M. Bukovsky		
Scott Burns		
Jack O. Banta		
Denese Taylor-Moye		
M. Evette Brantley		
John W. Olson		
Thomas C. McCarthy		
Jeanette Herron		
Michelle A. Lyons		
AmyMarie Vizzo-Paniccia		
Mary A. McBride-Lee		
Richard D. Salter, Sr.		
Jose Casco		
Alfredo Castillo		
Aidee Nieves		
Milta I. Feliciano		
Anthony R. Paoletto		
Nessah J. Smith		
Eneida L. Martinez		
James Holloway		

ATTEST
CITY CLERK

17 OCT -3 AM 11:26

RECEIVED
CITY CLERKS OFFICE

October 2, 2017

Honorable City Council
of the City of BPT
45 Lym Terrace
BPT, CT 06604

Re : Proposed Ordinance
Concerning Holding Landlords
Accountable for Tenant
Generated Noise Resulting
in Complaints Filed /
Warning Process + Fines for Repeated Violations

Dear Honorable Council Person :

Kindly ADD this Item to the Agenda
for Referral to Ordinance Committee
at the October 2, 2017 meeting

DRAFT LANGUAGE

"Recovery of Costs for Repeat Violations"

related to properties with chronic breaches of the peace,
public disturbances and disorderly conduct, pursuant
to C.G.S. Sec. 53a-181, 53a-181a and 53a-182.

Very Truly Yours,

Michelle Lyons, 134th D.

ATTEST
CITY CLERK

RECEIVED
CITY CLERKS OFFICE
17 OCT - 3 AM 11:12