



Prepared for:
City of Bridgeport
Office of Planning and Economic Development

HYDRAULIC ANALYSIS REPORT

City Project No. PEB72016A
Pedestrian Bridge over Ash Creek
Bridgeport, CT

Prepared By:  Date: 11/25/2020
David Cicia

Checked By:  Date: 11/30/2020
Brandon Rojas

PREPARED BY:
BL Companies
100 Constitution Plaza
10th Floor
Hartford, CT 06103



	PAGE
TABLE OF CONTENTS	
I. LOCATION MAP	1
II. INTRODUCTION	2
III. HYDRAULIC ANALYSIS METHODOLOGY	3
IV. WATER SURFACE PROFILE ANALYSIS	4
V. TEMPORARY CONDITIONS	5
VI. HYDRAULIC SUMMARY TABLES	7

FIGURES

FIGURE 1: GRADING PLAN

FIGURE 2: TRAIL PROFILE 1

FIGURE 3: TRAIL PROFILE 2

FIGURE 4: GENERAL PLAN, SECTION, AND ELEVATION

FIGURE 5: CONSTRUCTION STAGING PLAN

APPENDICES

APPENDIX A – HYDROLOGY

APPENDIX B – CROSS-SECTION LOCATIONS & CROSS-SECTIONS

APPENDIX C – WATER SURFACE PROFILE ANALYSIS

APPENDIX D – INUNDATION MAPS

PROPOSED BRIDGE LOCATION

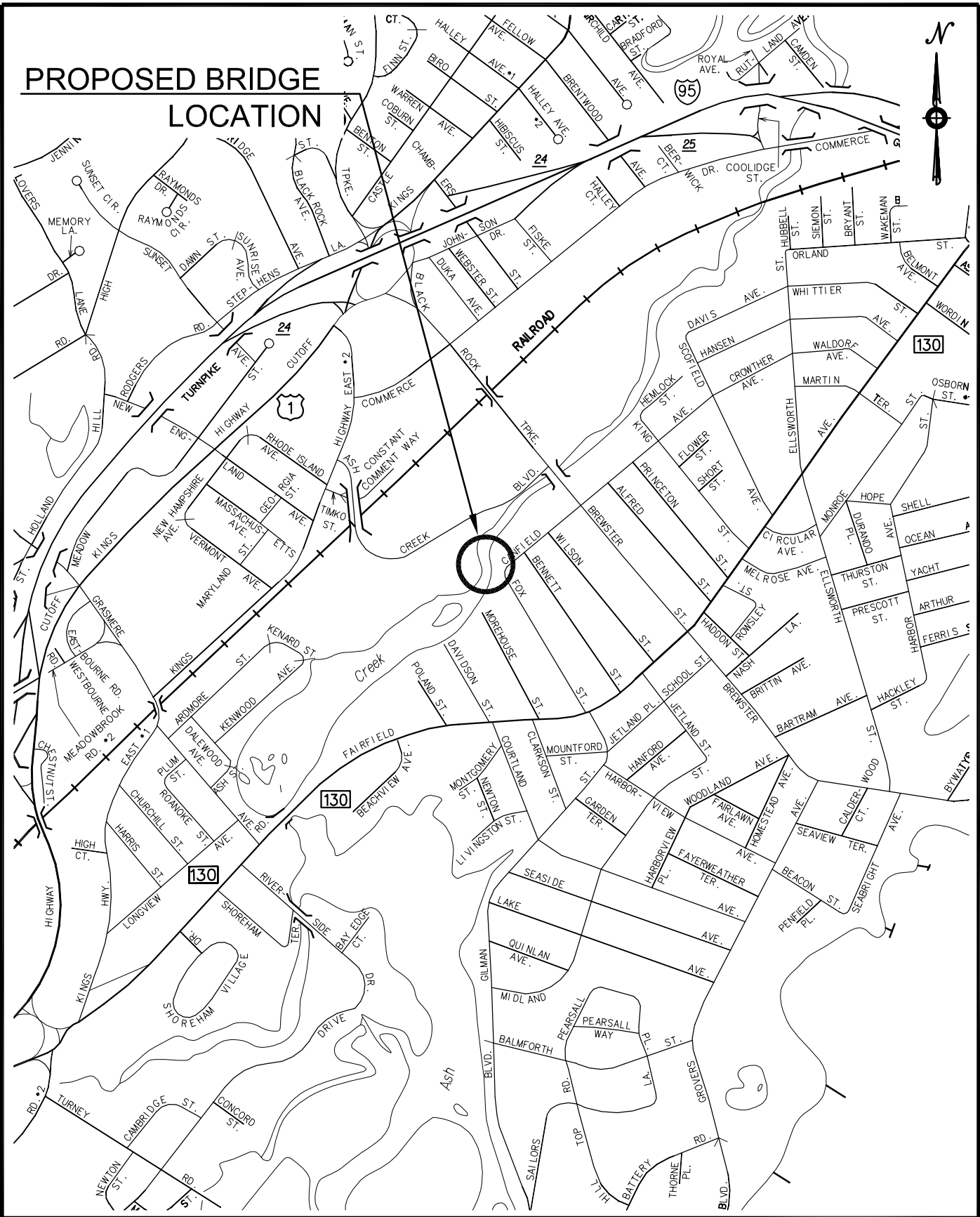

PEDESTRIAN BRIDGE
OVER
ASH CREEK
BRIDGEPORT, CT

LOCATION
MAP

SCALE: 1" = 1,000'

II. INTRODUCTION

This project consists of the construction of approximately 600 linear feet of trail, a pedestrian bridge and streetscape improvements. Approximately 300 linear feet of trail are proposed in Bridgeport and approximately 300 linear feet are proposed in Fairfield. The proposed pedestrian bridge over Ash Creek will be located at the northwest end of Fox Street in the city of Bridgeport (see Figure 1). The bridge will provide pedestrian access from Bridgeport, east of the creek, into Fairfield, west of the creek.

The project site is located approximately 0.9 miles downstream of the I-95 bridge over Ash Creek and approximately 1.4 miles upstream of the creek's outlet into Long Island Sound. Ash Creek, listed as Rooster River in the 2013 FEMA Flood Insurance Study, begins in the central portion of the town of Trumbull. Portions of the watershed are in Trumbull, Easton, Fairfield and Bridgeport. The creek flows primarily south through the watershed. From its beginning to the proposed bridge site, the watercourse is approximately 11.4 miles in length with an average streambed slope of 41 ft/mi.

At the proposed bridge site, Ash Creek has a drainage area of approximately 12.3 square miles (see Figure 2). The watershed was generated by the USGS StreamStats online utility and verified for accuracy using the Bridgeport, Long Hill, Botsford and Westport, CT USGS Quadrangle Maps. The area is in agreement with the Gazetteer of Drainage Areas of Connecticut, which lists a drainage area of 15.3 square miles at the creek's outlet into Long Island Sound. At this point, USGS StreamStats also computes a watershed area of 15.3 square miles.

The StreamStats flows are based on characteristics of nonurban drainage basins. Due to urbanization of the watershed, the StreamStats flows were adjusted using the seven-parameter regression equations included in the USGS publication, *Regression Equations for Estimating Flood Flows for the 2-, 10-, 25-, 50-, 100-, and 500-Year Recurrence Intervals in Connecticut*. Table 1 lists the flows prepared for the project. Refer to Appendix A for additional hydrologic information.

TABLE 1: SUMMARY OF FLOWS (cfs)

Pedestrian Bridge over Ash Creek	
Year	Urbanized USGS StreamStats
2	1,100
10	2,060
25	2,580
50	3,060
100	3,630
500	4,300

III. HYDRAULIC ANALYSIS METHODOLOGY

A hydraulic analysis of the proposed bridge crossing was performed using the Hydrologic Engineering Center’s River Analysis System (HEC-RAS, version 5.0.7). A plan view of Ash Creek, showing the arrangement of hydraulic cross-sections and the cross-sections with the existing and proposed 100-year WSEL are included in Appendix B (Cross-Section Locations and Cross-Sections).

At the proposed bridge location, Ash Creek is within the tidal influence of Long Island Sound. The tidal zone extends approximately 500 ft upstream of the bridge to Brewster Street (aka Black Rock Turnpike, as shown on the FEMA Flood Profile, Appendix A). The bridge is considered tidally affected (and not tidally controlled) as there is reverse flow during a high tide cycle, but the tidal action is not the dominant flow condition. The riverine flow is the dominant condition. As the riverine flow is dominant, the hydraulic analysis utilizes a steady state model.

Although Ash Creek was studied by FEMA (as Rooster River), the proposed bridge is located outside of the studied area since FEMA models start at the end of the tidal zone. In order to study the watercourse, field survey data was used to create the hydraulic model.

There is a total of eleven cross-sections in the hydraulic model. The sections approximately extend from 700 feet upstream of the bridge site to 500 feet downstream of the bridge site. Six cross-sections are located upstream of the bridge and five cross-sections are located downstream. Sections 568 and 5223 correspond to the upstream and downstream bridge faces, respectively. Section 660 is the approach section.

The proposed bridge was run utilizing two different starting tailwater elevations: 10-year tide and high tide. The 10-year tide is studied in compliance with the CT DEEP’s Hydraulic Analysis Guidance Document. High tide is studied in compliance with the DOT Drainage Manual. The bridge model was also run utilizing normal depth, however, the calculated normal depth elevations were below the high tide line and were not utilized (see Table 2).

TABLE 2: TAILWATER ELEVATION SUMMARY

	Design Year	Normal Depth Calculated (ft)
10-Year Tide Elevation 7.9 ft	2	1.23
	10	2.05
High Tide Elevation 4.8 ft	50	2.68
	100	2.98
	500	3.25

The results presented in the summary tables and, except where noted, the narrative sections below, use the 10-year tide tailwater elevation. For this model, the analysis uses the 100-year design storm of the watercourse (3,630 cfs) with the 10-year tidal tailwater elevation (7.9 ft) as the downstream control.

The Manning's Roughness Coefficient used for both the upstream and downstream channel for the existing and proposed conditions is 0.03. The channel is clean, slightly sinuous, and without vegetation. The overbank coefficients vary based on ground type. Areas of vegetation use a value of 0.05. Channel bank areas outside the main channel use a value of 0.035. Pavement areas of the overbank use a value of 0.016. Since the bridge is elevated above the FEMA 100-year storm event, there is no change to the contraction and expansion coefficients near the bridge. All sections use values of 0.1 for contraction and 0.3 for expansion.

The hydraulic analysis procedure used by the HEC-RAS program is based on the solution of the one-dimensional energy equation. The head loss in the energy equation is comprised of friction losses (utilizing Manning's equation) and contraction/expansion losses (coefficient multiplied by the change in velocity head). The HEC-RAS bridge-modeling approach utilizes the energy equation for all flows.

IV. WATER SURFACE PROFILE ANALYSIS

See "Table 3: Summary of the 100-Year WSEL" for a comparison of the calculated 100-year water surface elevations. See "Table 4: Summary of the 100-Year Velocity" for a comparison of the calculated 100-year velocities. This data will be utilized in discussions located further in this section.

A. EXISTING CONDITIONS

The 100-year existing water surface elevation (WSEL) at the approach section to the proposed bridge (Section 660) is 8.00 ft. The WSEL at the location of the upstream bridge face (Section 568) is 7.85 ft and the WSEL at the location of the downstream bridge face (Section 522) is 7.91 ft.

At the locations of the approach section and upstream bridge face, the 100-year velocities are 3.10 ft/s and 4.06 ft/s, respectively. At the location of the downstream bridge face, the 100-year velocity is 3.00 ft/s.

Due to using the 10-year tide elevation for the downstream boundary condition for all events, there is little change to the computed WSEL during the 500-year event. The existing 500-year WSELs range between 0.02 ft below to 0.11 ft above the existing 100-year WSELs. The existing 500-year WSEL at the approach section is 8.04 ft. The existing 500-year WSEL at the upstream bridge face is 7.83 ft and the existing 500-year WSEL at the downstream bridge face is 7.92 ft.

A comparison between the existing and proposed water surface elevations can be found in the section below. A comparison printout of the HEC-RAS 100-year water surface profile and a profile output table for all storm events are included in Appendix C (Water Surface Profile Analysis).

B. PROPOSED CONDITIONS

The proposed bridge consists of a fabricated structural steel truss superstructure on reinforced concrete abutments and founded on a micropile deep foundation. The proposed bridge will have a clear span of 225 feet. The bridge is designated solely for pedestrians and bicyclists to cross Ash Creek safely while at the same time providing passive recreational use in the area.

The proposed bridge will be 14 feet wide. The low chord of the bridge will be at elevation 10.5 feet, 0.5 feet above the FEMA 100-year tide of 10.0 feet. The upstream bridge that carries Brewster Street over Ash Creek has a low chord of approximately 14 feet (+/-). An arch bridge, which carries Fairfield Avenue (Route 130) over Ash Creek downstream of the project area, has a low chord of 7 feet (+/-), restricting navigability of the channel.

The proposed bridge will not have an effect on the hydraulics of the watercourse since the bridge is elevated above the 100-year tide elevation. If a 500-year storm occurs, the bridge area and volume of material is insignificant compared to the inundation of such a major storm event.

The calculated 100-year WSELs and velocities are virtually the same as the existing conditions. At Section 950, there is a calculated 0.01 ft increase in elevation. At Section 568, there is a calculated 0.01 ft/s increase in velocity. Neither increase will have any effect on the performance of the watercourse. The 500-year event shows a similar lack of impact.

The steel truss superstructure will be constructed from smaller prefabricated sections on-site. The west approach (Fairfield side) will have two sections while the east approach (Bridgeport side) is expected to have three sections. Once the smaller sections are spliced on each approach, the Contractor, by means of cranes, will set each larger segment on an abutment and a temporary support (work) platform. This temporary platform will be located near the middle portion of Ash Creek and will allow for the final splicing of the larger segments of the bridge superstructure.

The temporary work platform will serve as a means for the iron workers to get access to the location where the superstructure is to be spliced as well as serving as a temporary support for the two large bridge segments to rest while the splicing is being performed. The temporary work platform will be founded on temporary steel piles which will be removed upon the completion of the bridge construction.

A comparison printout of the HEC-RAS 100-year water surface profile and a profile output table for all storm events are included in Appendix C (Water Surface Profile Analysis).

V. TEMPORARY CONDITIONS

Work within or adjacent to Ash Creek will be conducted during periods of low flow. The Owner/Engineer shall remain aware of flow conditions during the conduct of such work and will order such work stopped if flow conditions threaten to cause excessive erosion, siltation or turbidity. Before predicted major storms (i.e., a storm predicted by NOAA Weather Service,

with warnings of flooding, severe thunderstorms, or similarly severe weather conditions), the Contractor shall make every effort to secure the Site to the satisfaction of the Owner/Engineer.

Contractor staging areas will be provided on the Fairfield and Bridgeport sides of Ash Creek. These properties abut the proposed work area and are appropriate for staging areas. The Contractor will follow Best Management Practices to prevent debris from entering the watercourse.

Cofferdams will be constructed along the trail approaches to the bridge. The cofferdams will be elevated to 8.0 ft, 0.1 ft above the height of the FEMA 10-year flood (7.9 ft).

VI. HYDRAULIC SUMMARY TABLES

TABLE 3: SUMMARY OF THE 100-YR WSEL

WATER SURFACE ELEVATIONS (NAVD 1988) 100-YEAR FLOW – 3,630 CFS				
Section	Existing	Proposed	Proposed vs. Existing	Comments
1260	8.16	8.16	0.00	
1090	8.07	8.07	0.00	
950	8.04	8.05	+0.01	
740	8.06	8.06	0.00	
660	8.00	8.00	0.00	Approach Section
568	7.85	7.85	0.00	Upstream Face
552	---	---	---	Proposed Bridge
522	7.91	7.91	0.00	Downstream Face
340	7.90	7.90	0.00	
295	7.90	7.90	0.00	
100	7.89	7.89	0.00	
0	7.90	7.90	0.00	

TABLE 4: SUMMARY OF THE 100-YR VELOCITY

VELOCITY COMPARISON (FT/S) 100-YEAR FLOW – 3,630 CFS				
Section	Existing	Proposed	Proposed vs. Existing	Comments
1260	3.32	3.32	0.00	
1090	3.63	3.63	0.00	
950	3.48	3.48	0.00	
740	2.51	2.51	0.00	
660	3.10	3.10	0.00	Approach Section
568	4.06	4.05	-0.01	Upstream Face
552	---	---	---	Proposed Bridge
522	3.00	3.00	0.00	Downstream Face
340	2.60	2.60	0.00	
295	2.43	2.43	0.00	
100	1.99	1.99	0.00	
0	1.57	1.57	0.00	

NOT FOR
CONSTRUCTION

FOX STREET STREETSCAPE IMPROVEMENTS,
PEDESTRIAN BRIDGE OVER ASH CREEK,
& MULTI-USE TRAIL ALONG ASH CREEK
BRIDGEPORT, CONNECTICUT

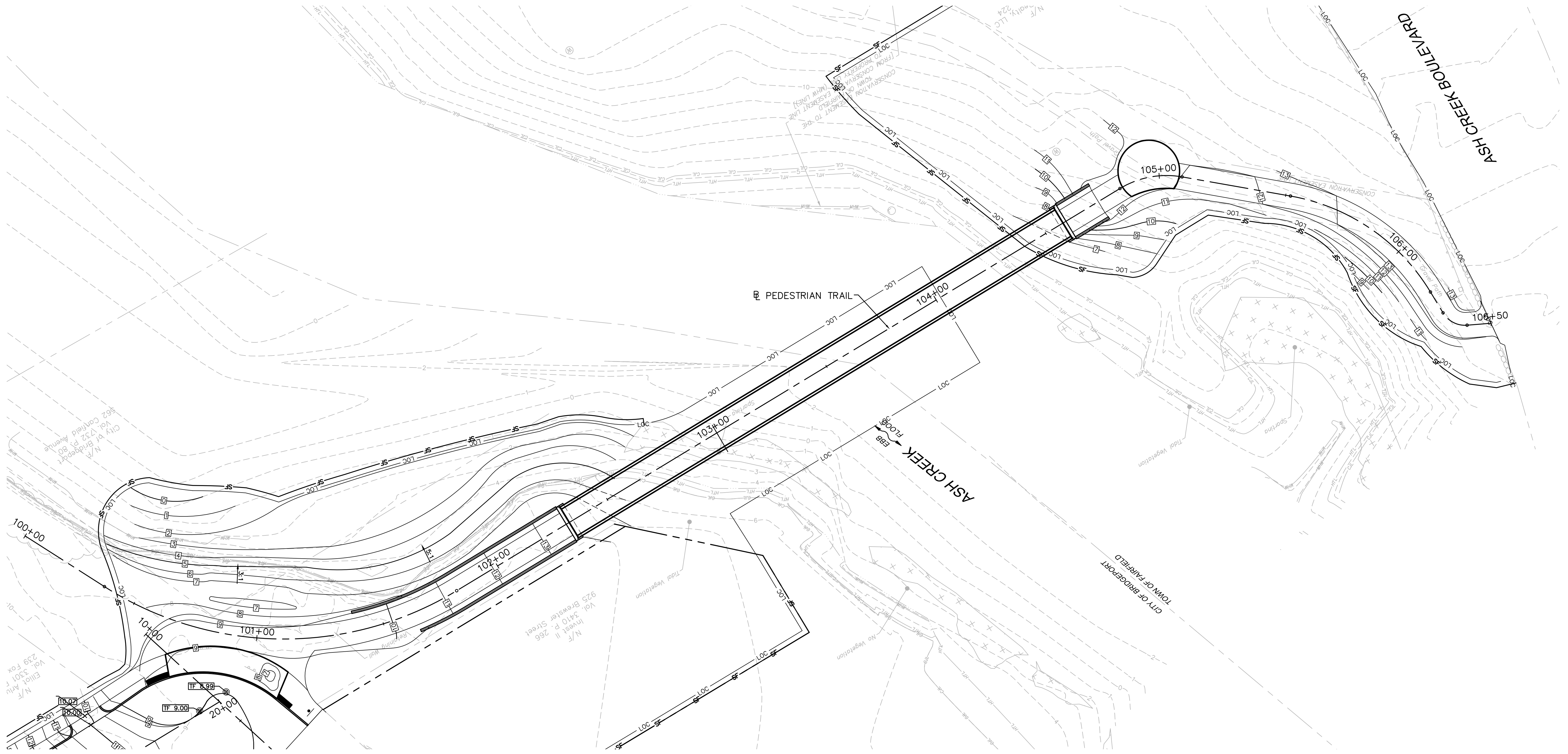

PEDESTRIAN TRAIL

NOTES

- 1. SEE SHEET PLN-7 FOR DETAILED GRADING OF THE INTERSECTION OF FOX STREET AND CANFIELD AVENUE.

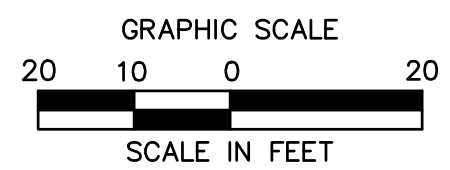

No.	Date	Desc.
REVISIONS		

Designed	C.L.M.
Drawn	C.L.M.
Reviewed	
Scale	1"=20'
Project No.	15C5687
Date	09/23/2020
CAD File:	TGRA15C568701
Title	GRADING PLAN
Sheet No.	

GRA-1

11/25/2020, C:\A\STRAND, G. \PROJECTS\15C\15C5687\DWG\TPRO15C56870.DWG, TPRO-1, 24X36, 20SC.

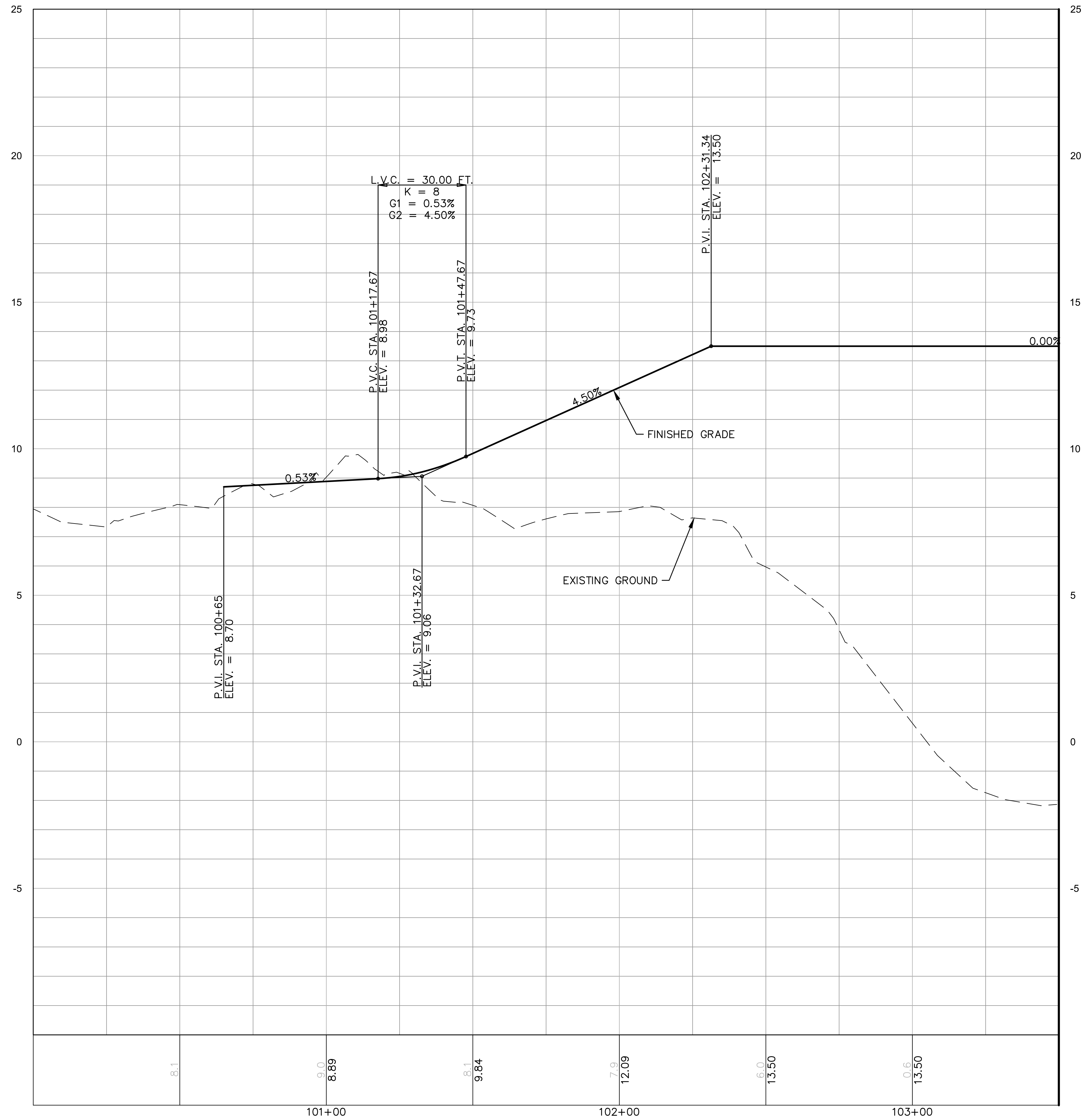

PEDESTRIAN TRAIL PROFILE

MATCH LINE STA. 103+50
SEE SHEET PRO-2

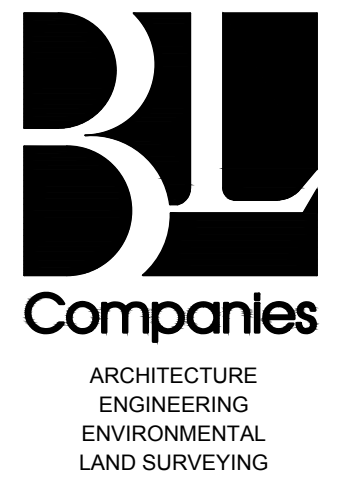
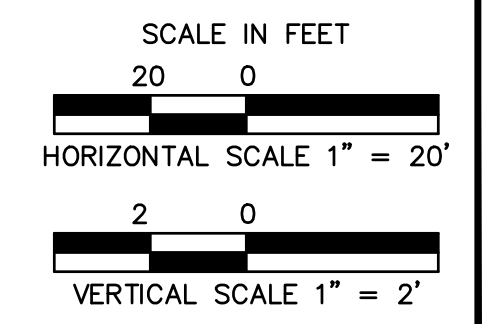

100 Constitution Plaza, 10th Floor
Hartford, CT 06103
(203) 630-1406
(203) 630-2615 Fax

NOT FOR
CONSTRUCTION

**FOX STREET STREETSCAPE IMPROVEMENTS,
PEDESTRIAN BRIDGE OVER ASH CREEK,
& MULTI-USE TRAIL ALONG ASH CREEK
BRIDGEPORT, CONNECTICUT**

REVISIONS	No.	Date	Desc.

Designed	C.L.M.
Drawn	C.L.M.
Reviewed	
Scale	1"=20'
Project No.	15C5687
Date	09/23/2020
CAD File:	TPRO15C568701

Title
**TRAIL
PROFILE**

Sheet No.

PRO-1

Xref (s) : BDI5C568701 ; XRI5C568702 ; XRI5C568701

NOT FOR
CONSTRUCTION

FOX STREET STREETScape IMPROVEMENTS,
PEDESTRIAN BRIDGE OVER ASH CREEK,
& MULTI-USE TRAIL ALONG ASH CREEK
BRIDGEPORT, CONNECTICUT

REVISIONS	No.	Date	Desc.

Designed C.L.M.
Drawn C.L.M.
Reviewed
Scale 1"=20'
Project No. 15C5687
Date 09/23/2020
CAD File: TPR015C568701
Title
**TRAIL
PROFILE**
Sheet No.
PRO-2

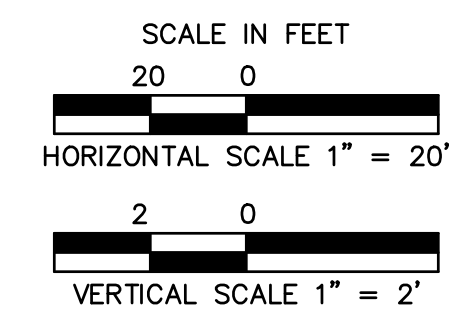
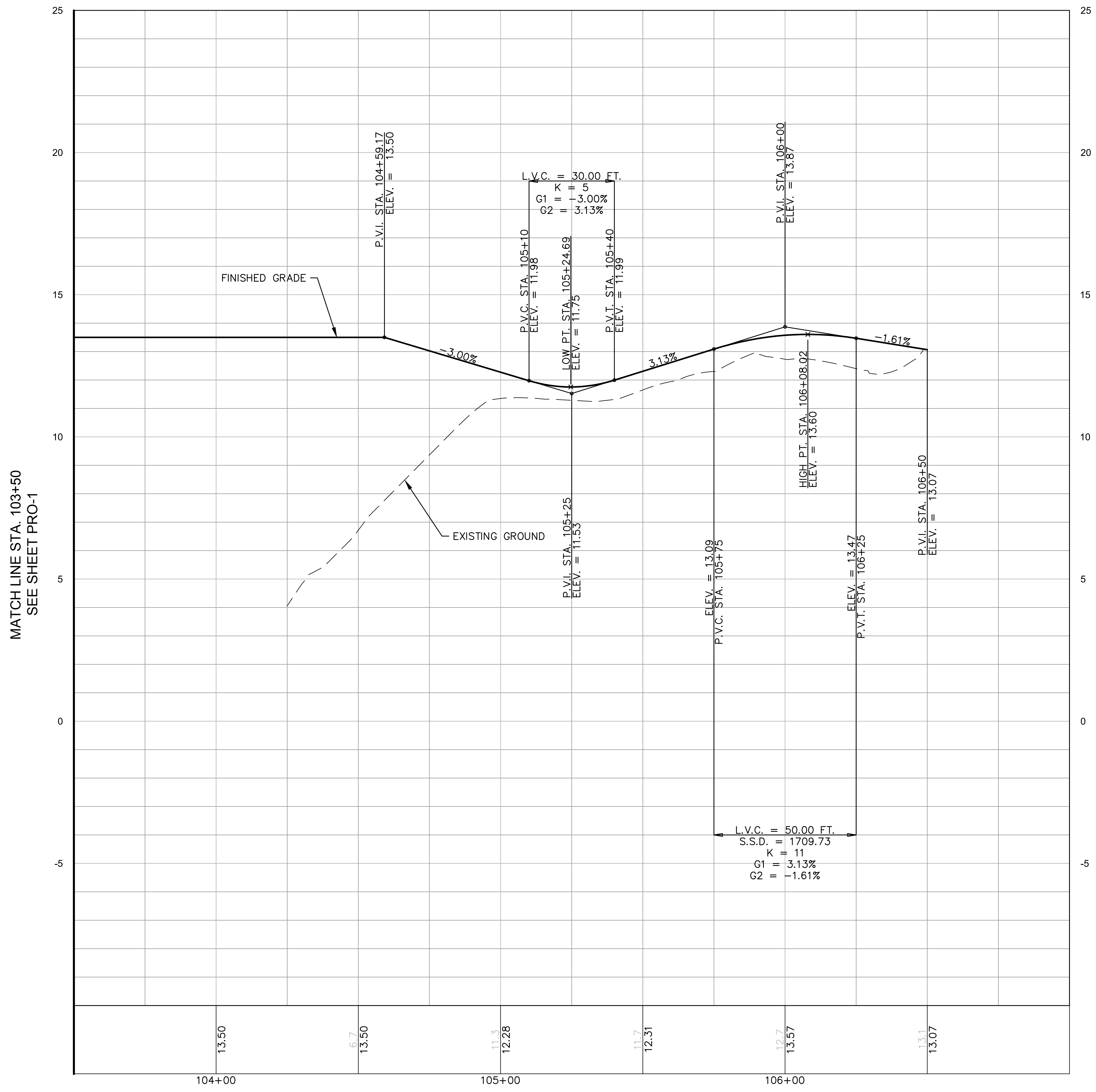

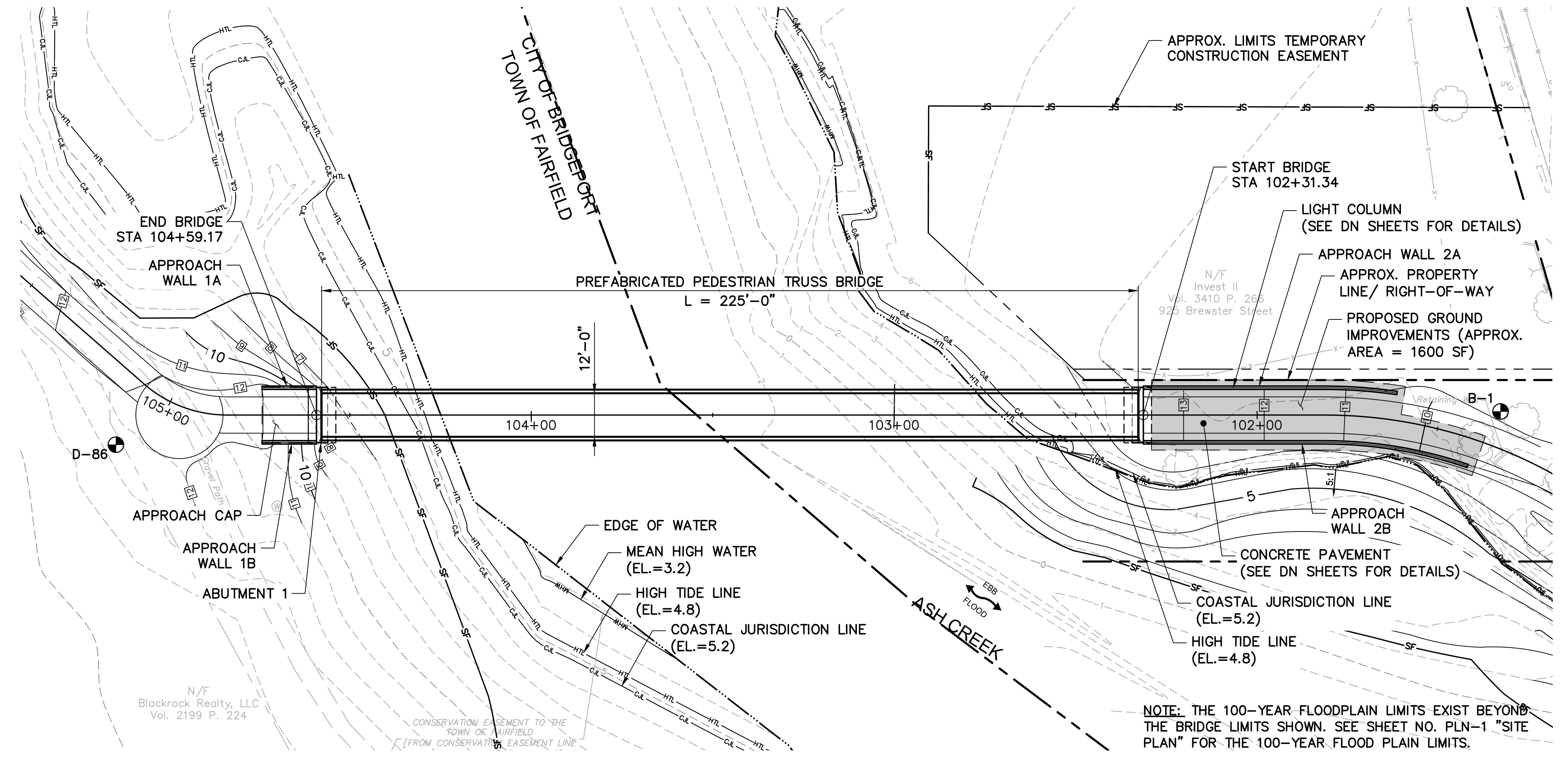

GENERAL PLAN
SCALE: 1" = 20'-0"

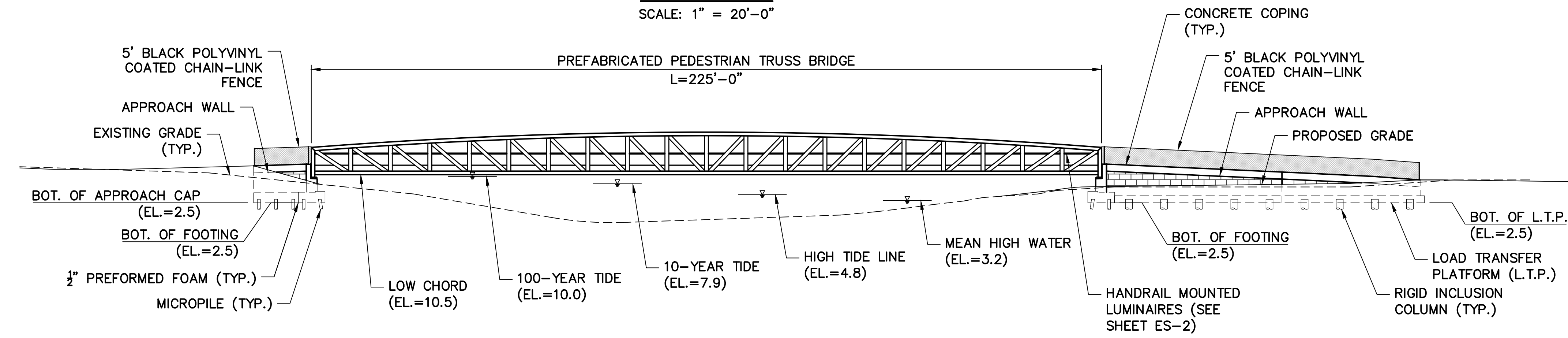

ELEVATION
SCALE: 1" = 20'-0"

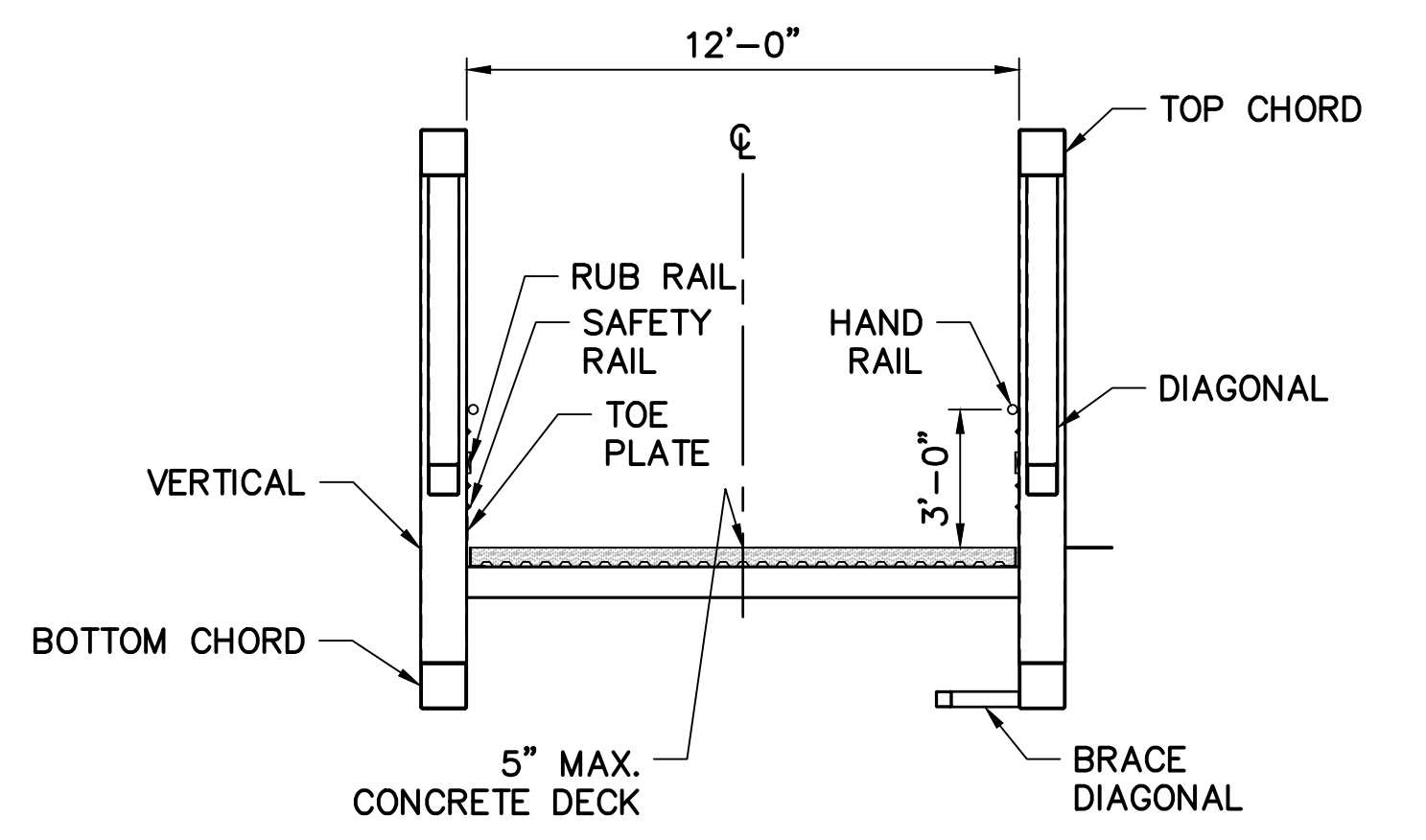

NOTE: APPROXIMATE 20' TRANSITION FROM FACE OF BACKWALL TO NORMAL CROWN OVER BRIDGE (BOTH SIDES).
TYPICAL SECTION - AT STA 102+32.59 AND STA 104+60.42
SCALE: 1/4" = 1'-0"

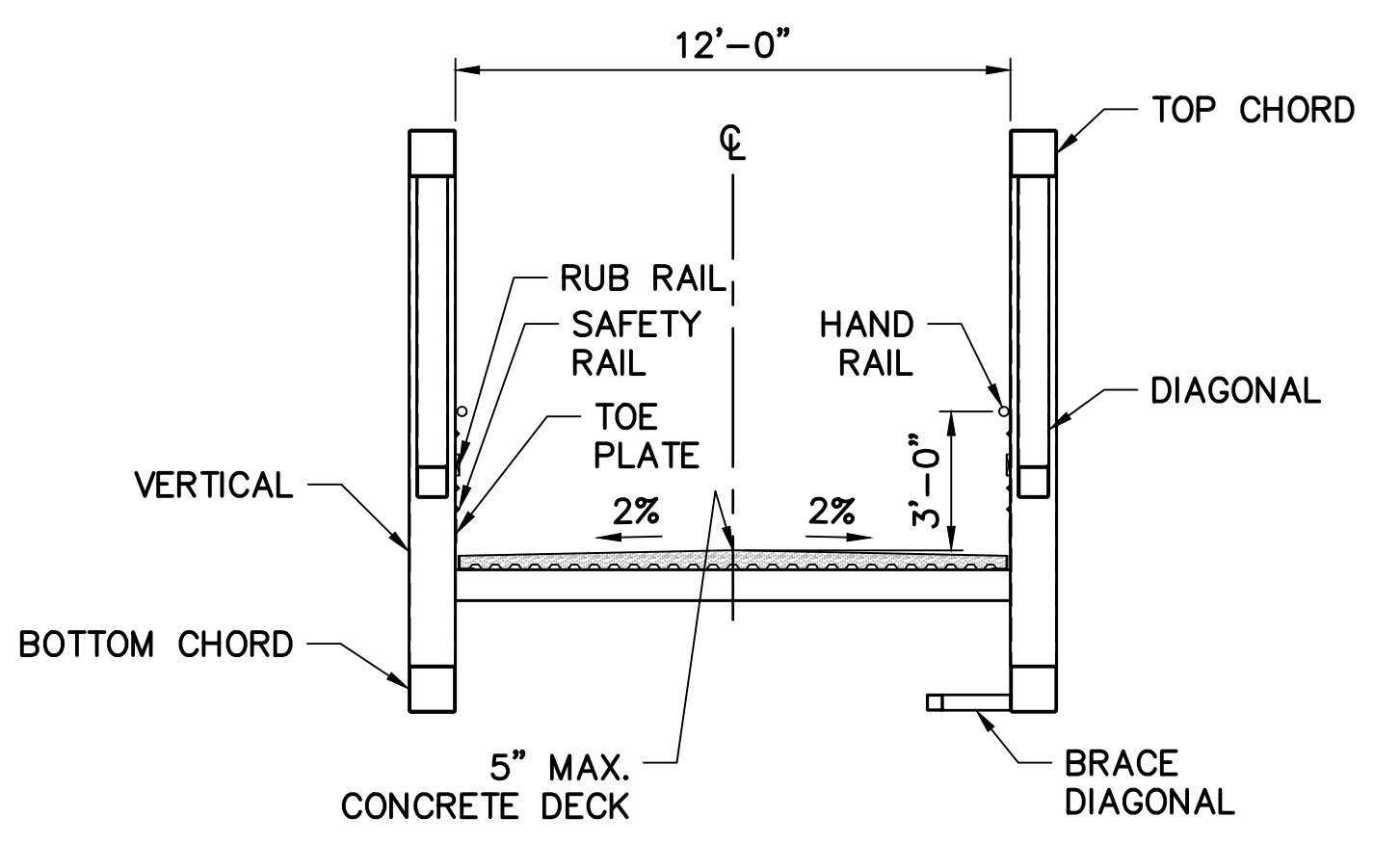

NOTE: APPROXIMATE 20' TRANSITION FROM FACE OF BACKWALL TO NORMAL CROWN OVER BRIDGE (BOTH SIDES).
TYPICAL SECTION - FROM STA 102+52.59 TO STA 104+40.42
SCALE: 1/4" = 1'-0"

DRAWING INDEX	
GENERAL PLAN, SECTION, AND ELEVATION	S-1
LAYOUT PLAN AND QUANTITIES	S-2
BORING LOGS	S-3
ABUTMENT DETAILS	S-4
MICROPILE DETAILS	S-5
BEARING ASSEMBLY DETAILS	S-6
APPROACH WALL DETAILS - 1	S-7
APPROACH WALL DETAILS - 2	S-8
CONSTRUCTION STAGING PLAN	S-9

HYDRAULIC DATA ASH CREEK	
MEAN LOW WATER	-3.7 ft
MEAN HIGH WATER	3.2 ft
HIGH TIDE LINE (1-YEAR TIDE)	4.8 ft
10-YEAR TIDE	7.9 ft
100-YEAR TIDE	10.0 ft
DESIGN FREQUENCY	Tidal: 10-Year Riverine: 100-Year
DESIGN DISCHARGE	3,630 cfs
DESIGN WSEL - EBB DIRECTION	8.0 ft
DESIGN WSEL - FLOOD DIRECTION	7.91 ft

LEGEND	
	X-X APPROXIMATE BORING LOCATION
	—MHW— MEAN HIGH WATER LINE (EL. = 3.2)
	—HTL— HIGH TIDE LINE (EL. = 4.8)
	—CJL— COASTAL JURISDICTION LINE (EL. = 5.2)

GENERAL NOTES

SPECIFICATIONS: CONNECTICUT DEPARTMENT OF TRANSPORTATION FORM 817 (2016), SUPPLEMENTAL SPECIFICATIONS DATED JULY 2017 AND SPECIAL PROVISIONS.

DESIGN SPECIFICATIONS: AASHTO LRFD SPECIFICATIONS FOR HIGHWAY BRIDGES, 7TH EDITION (2014) AS SUPPLEMENTED BY THE CONNECTICUT DEPARTMENT OF TRANSPORTATION BRIDGE MANUAL (2003) EDITION WITH REVISIONS UP TO AND INCLUDING 2011.

ALLOWABLE DESIGN STRESSES:

CLASS "A" CONCRETE:	f'c = 3,000 psi
CLASS "F" CONCRETE:	f'c = 4,000 psi
GROUT:	f'c = 4,000 psi
REINFORCEMENT (ASTM 615 GRADE 60)	fy = 60,000 psi

LOADINGS:

DESIGN VEHICLE:	H-10
PEDESTRIAN LIVE LOAD:	90 PSF
WIND LOAD:	35 PSF

SALVAGE: NONE

DIMENSIONS AND ELEVATIONS: WHEN DECIMAL DIMENSIONS AND ELEVATIONS ARE GIVEN TO LESS THAN TWO DECIMAL PLACES, THE OMITTED DIGITS SHALL BE ASSUMED TO BE ZERO. ALL ELEVATIONS ARE GIVEN IN DECIMAL FEET AND ARE BASED ON NAVD 88.

EXISTING DIMENSIONS: DIMENSIONS OF THE EXISTING STRUCTURE SHOWN ON THESE PLANS ARE FOR GENERAL REFERENCE ONLY AND ARE NOT GUARANTEED. THE CONTRACTOR SHALL TAKE ALL FIELD MEASUREMENTS NECESSARY TO ASSURE PROPER FIT OF THE FINISHED WORK AND SHALL ASSUME FULL RESPONSIBILITY FOR THEIR ACCURACY. WHEN SHOP DRAWINGS BASED ON FIELD MEASUREMENTS ARE SUBMITTED FOR APPROVAL, THE FIELD MEASUREMENTS SHALL ALSO BE SUBMITTED FOR REFERENCE BY THE REVIEWER.

CONCRETE NOTES

CLASS "A" CONCRETE: CLASS "A" CONCRETE SHALL BE USED FOR THE ABUTMENT FOOTINGS AND STEMS.

CLASS "F" CONCRETE: CLASS "F" CONCRETE SHALL BE USED FOR THE DECK SLAB, PEDESTALS, AND THE BACKWALLS.

GROUT: GROUT SHALL BE USED FOR THE MICROPILES AND INCLUDED IN THE PAY ITEM "MICROPILES". SEE SHEET NO. S-5 FOR MATERIAL SPECIFICATIONS.

EXPOSED EDGES: EXPOSED EDGES OF CONCRETE SHALL BE BEVELED 1" X 1", UNLESS DIMENSIONED OTHERWISE.

CONCRETE COVER: ALL REINFORCEMENT SHALL HAVE TWO INCHES COVER UNLESS DIMENSIONED OTHERWISE.

REINFORCEMENT: ALL REINFORCEMENT SHALL BE ASTM A615 GRADE 60 UNLESS OTHERWISE NOTED (U.O.N.).

EPOXY COATED REINFORCEMENT BARS: ALL REINFORCEMENT IN THE BACKWALLS AND DECK SLAB SHALL BE EPOXY COATED AND SHALL BE PAID FOR IN THE PAY ITEM "DEFORMED STEEL BARS (EPOXY COATED)".

PREFORMED FOAM: THE COST OF FURNISHING AND INSTALLING PREFORMED FOAM SHALL BE INCLUDED IN THE ITEM "CLASS 'A' CONCRETE".

CONSTRUCTION JOINTS: CONSTRUCTION JOINTS, OTHER THAN THOSE SHOWN ON THE PLANS, WILL NOT BE PERMITTED WITHOUT PRIOR APPROVAL OF THE ENGINEER.

PREFABRICATED STEEL TRUSS: THIS DRAWING IS BASED OFF OF A CONTECH "CONTINENTAL STEEL TRUSS". THE CONTRACTOR CAN ELECT TO USE A SIMILAR TRUSS DESIGN AS APPROVED BY THE ENGINEER. SEE SPECIAL PROVISION.

APPROACH WALL: THE COST OF APPROACH WALLS ARE PAID FOR UNDER "RETAINING WALL (SITE NO. 1)".

NOT FOR CONSTRUCTION

FOX STREET STREETSCAPE IMPROVEMENTS,
PEDESTRIAN BRIDGE OVER ASH CREEK,
& MULTI-USE TRAIL ALONG ASH CREEK
BRIDGEPORT, CONNECTICUT

REVISIONS	
No.	Date

Designed	T.B.
Drawn	B.S.O.
Reviewed	C.A.P.

Scale	AS NOTED
Project No.	15C5687
Date	09/23/2020
CAD File:	TBRG15C568709

Title	
CONSTRUCTION STAGING PLAN	
Sheet No.	

GENERAL NOTES

1. THE CONTRACTOR SHALL SUBMIT A DETAILED PLAN AND NARRATIVE DESCRIBING THE CONSTRUCTION SEQUENCE. THE CONSTRUCTION SEQUENCE SHOWN IS A SUGGESTED CONCEPT THAT IS CONSIDERED FEASIBLE FOR PERFORMING THE WORK WHILE SATISFYING THE PERMIT REQUIREMENTS OF THE PROJECT. THIS SHEET IS ONLY INTENDED TO PROVIDED INFORMATION PERTINENT FOR THE DEVELOPMENT OF THE CONTRACTOR'S DETAILED CONSTRUCTION SEQUENCE.
2. BEST MANAGEMENT PRACTICES (BMP) SHALL BE UTILIZED AS APPROPRIATE AND SHALL BE CONSISTENT WITH THE CONNECTICUT GUIDELINES FOR SOIL EROSION AND SEDIMENT CONTROL.
3. CONSTRUCTION ACTIVITIES SHALL CONFORM TO SECTION 1.10, ENVIRONMENTAL COMPLIANCE FROM THE STANDARD SPECIFICATIONS FOR ROADS, BRIDGES, AND INCIDENTAL CONSTRUCTION, FORM 817, 2016, STATE OF CONNECTICUT, DEPARTMENT OF TRANSPORTATION.
4. DEWATERING, IF NEEDED, SHALL UTILIZE BMP AS APPLICABLE.
5. THE TEMPORARY WORK PLATFORM, IF DEEMED NECESSARY BY THE CONTRACTOR, WILL BE INCLUDED IN THE LUMP SUM PRICE OF "PEDESTRIAN BRIDGE."

SUGGESTED SEQUENCE OF CONSTRUCTION

- STAGE 1**
1. INSTALL SEDIMENTATION AND EROSION CONTROL MEASURES AS REQUIRED.
 2. INSTALL TEMPORARY ACCESS ROAD, TEMPORARY LATERAL SUPPORT, AND TEMPORARY LEVEL CRANE PADS, AS SHOWN.
 3. EXPOSE HDPE MEMBRANE IN THE VICINITY OF THE PROPOSED ABUTMENTS.
 4. CUT MEMBRANE AND INSTALL EARTH RETAINING SYSTEM, AS SHOWN.
 5. INSTALL MICROPILES.
 6. CONSTRUCT ABUTMENT FOOTINGS, ABUTMENT STEMS, AND PEDESTALS.
 7. APPLY DAMPPROOFING TO ABUTMENT STEMS.
 8. INSTALL/CONSTRUCT RETAINING WALLS.
 9. BACKFILL STRUCTURE PER SPECIFICATIONS.
- STAGE 2**
1. INSTALL PEDESTRIAN BRIDGE.
 2. CAST CONCRETE DECK.
 3. CONSTRUCT TRAIL.
 4. BEGIN SITE RESTORATION, INSTALL TOPSOIL, TURF ESTABLISHMENT, AND RIPRAP ALONG EMBANKMENTS.
 5. REMOVE SEDIMENTATION AND EROSION CONTROL MEASURES.
 6. PERFORM FINAL SITE CLEAN UP.

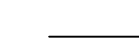
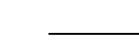
LEGEND	
	MEAN HIGH WATER LINE (EL. = 3.2)
	HIGH TIDE LINE (EL. = 4.8)
	COASTAL JURISDICTION LINE (EL. = 5.2)

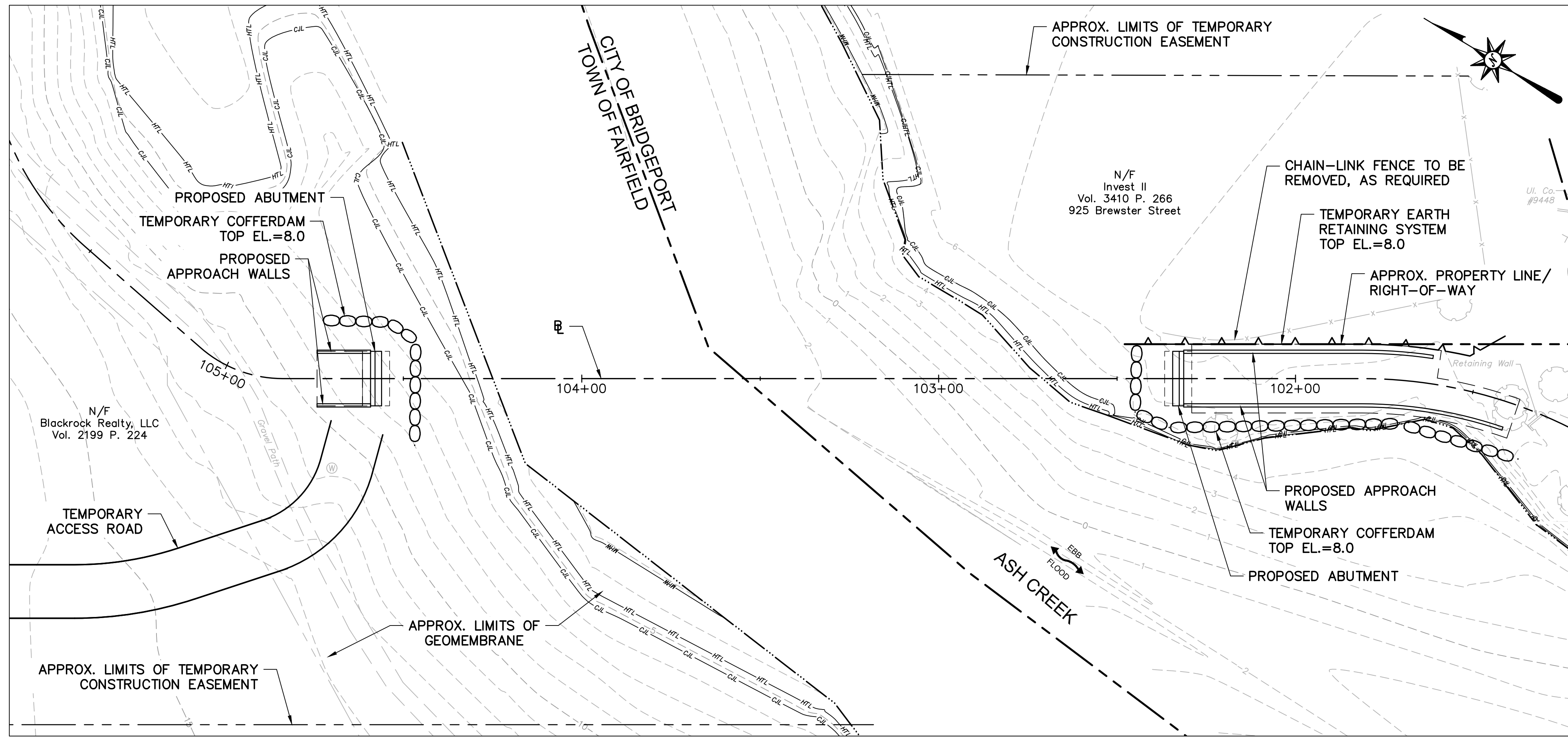

STAGE 1
SCALE: 1" = 20'-0"

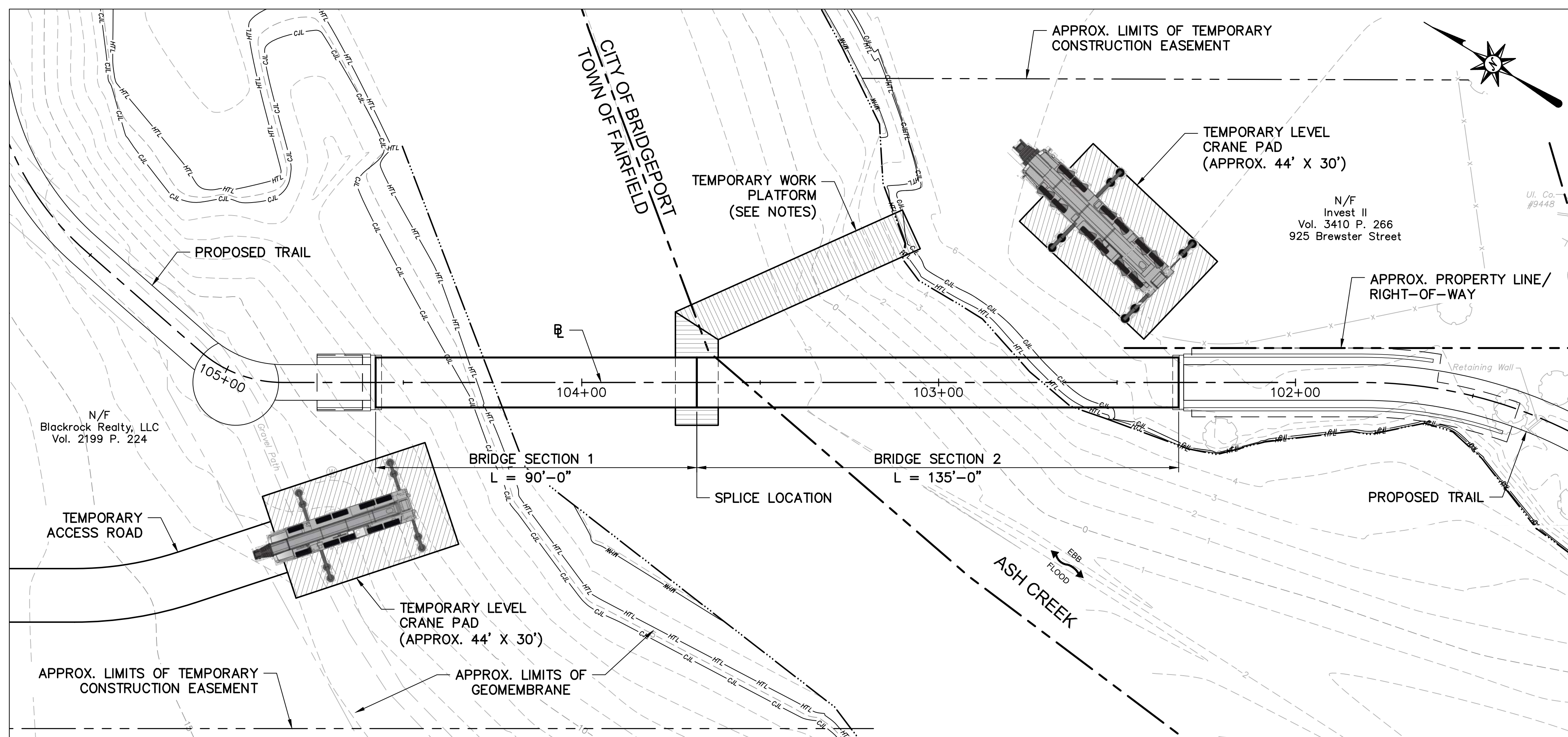

STAGE 2
SCALE: 1" = 20'-0"

11/25/2020, TBLACK, G. VORREIS\15C\5687\DWG\15C568709.DWG, S=9, 24X36, AS NOTED.

APPENDIX A – HYDROLOGY



Approved By:

Prepared for:
City of Bridgeport
Office of Planning and Economic Development

HYDROLOGIC ANALYSIS REPORT

City Project No. PEB72016A
Pedestrian Bridge over Ash Creek
Bridgeport, CT

Prepared By:  Date: 9/29/2016
David Cicia

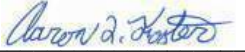
Checked By:  Date: 10/3/2016
Aaron Foster

PREPARED BY:
BL Companies
100 Constitution Plaza
10th Floor
Hartford, CT 06103



TABLE OF CONTENTS		PAGE
I.	LOCATION MAP	1
II.	WATERSHED CHARACTERISTICS.....	2
III.	HYDROLOGIC METHODOLOGY	3
IV.	STUDY RESULTS.....	4

TABLES AND FIGURES

TABLE 1: SUMMARY OF FLOWS (C.F.S.).....	4
FIGURE 1: PROBABILITY CHART FOR ALL METHODS	5
FIGURE 2: WATERSHED BOUNDARY MAP	6
FIGURE 3: SURFICIAL MATERIALS MAP	7
FIGURE 4: FEMA FLOOD INSURANCE RATE MAP	8

APPENDICES

- APPENDIX A: METHOD 1 – FEMA FIS FLOWS
- APPENDIX B: METHOD 2 – TRANSFERRED GAGE DATA
- APPENDIX C: METHOD 3 – URBANIZED USGS STREAMSTATS

PROPOSED BRIDGE LOCATION

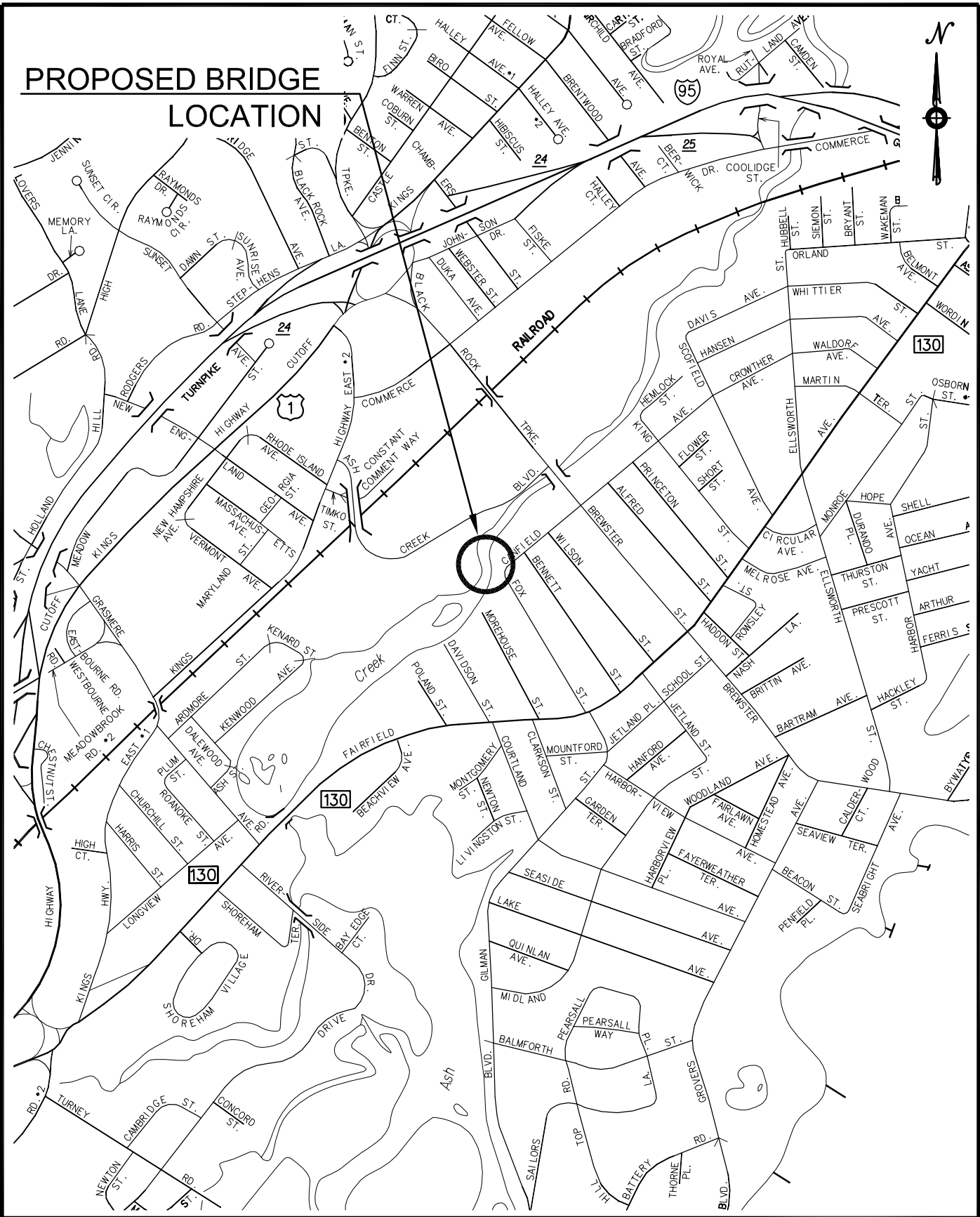

PEDESTRIAN BRIDGE
OVER
ASH CREEK
BRIDGEPORT, CT

LOCATION
MAP

SCALE: 1" = 1,000'

II. WATERSHED CHARACTERISTICS

The proposed pedestrian bridge over Ash Creek will be located at the northwest end of Fox Street in the city of Bridgeport (see Figure 1). The bridge will provide pedestrian access from Bridgeport, east of the creek, into Fairfield, west of the creek. The site is located approximately 0.9 miles downstream of the I-95 bridge over Ash Creek and approximately 1.4 miles upstream of the creek's outlet into Long Island Sound. Ash Creek, listed as Rooster River in the FEMA *Flood Insurance Study*, begins in the central portion of the town of Trumbull. Portions of the watershed are in Trumbull, Easton, Fairfield and Bridgeport. The creek flows primarily south through the watershed. From its beginning to the proposed bridge site, the watercourse is approximately 11.4 miles in length with an average streambed slope of 41 ft/mi.

At the proposed bridge site, Ash Creek has a drainage area of approximately 12.3 square miles (see Figure 2). The watershed was generated by the USGS StreamStats online utility and verified for accuracy using the Bridgeport, Long Hill, Botsford and Westport, CT USGS Quadrangle Maps. The area is in agreement with the Gazetteer of Drainage Areas of Connecticut, which lists a drainage area of 15.3 square miles at the creek's outlet into Long Island Sound. At this point, USGS StreamStats also computes a watershed area of 15.3 square miles.

Comparison to the USGS Quadrangle Maps, and supplemented by aerial photography, indicates that the watershed is highly urbanized, with development extending throughout the watershed. Delineation of surficial materials indicates that approximately 85% of the watershed is underlain with glacial till, 14% is underlain with stratified deposits and 1% contains waterbodies (see Figure 3). The site is located within Zone AE on the FEMA Flood Insurance Rate Map (see Figure 4). The site is also located within the tidal zone of Long Island Sound. The FEMA Flood Profile shows the tidal effect extends upstream of the proposed bridge site approximately 1,000-feet to Black Rock Turnpike (which becomes Brewster Street when traveling east into Bridgeport). The ConnDOT Drainage Manual classifies the proposed bridge as a large structure (providing waterway for drainage areas between 1 and 10 square miles) with a 100-year design storm event. As the proposed bridge is providing a pedestrian crossing, coordination with the city will be made to determine the required design storm to be used.

The watershed extends to the north beyond Canoe Brook Lake in Trumbull. The upper third of the watershed (north of the Merritt Parkway) is narrow in width and contains residential developments and a large 60 acre wooded area north of the lake. The approximate average size of the residential areas is 0.5 acres. The watershed slightly widens in the central and lower thirds. The central third contains Fairchild-Wheeler Park and Ninety Acres Park, which are the two largest non-developed areas of the watershed. Outside of these parks, virtually the entire central area contains residential developments, with an approximate lot size of 0.3 acres. The lower third contains Brooklawn Country Club in Fairfield and Mount Grove Cemetery in Bridgeport. The vast majority of the lower third contains dense residential developments and commercial areas.

III. HYDROLOGIC METHODOLOGY

The calculated flows in this hydrologic study were compared using three methods.

1. **Method 1 – FEMA Flood Insurance Study (FIS):** The data used for this analysis is based off of the *Flood Insurance Study, Fairfield County, Connecticut, revised October 16, 2013* by the Federal Emergency Management Agency (FEMA). The FIS contains published flows for Rooster River that extend to a point approximately 1,250-feet downstream of Black Rock Turnpike (as shown on the Flood Profile). This point is approximately 250-feet downstream of the proposed pedestrian bridge, therefore the flows are applicable for the proposed site. See Appendix A for portions of the Fairfield County FIS. The FIS flows will not be utilized for the hydraulic analysis.
2. **Method 2 – Transferred Gage Data:** USGS Gage No. 01208873 (Rooster River at Fairfield) is located at the U.S. Route 1 bridge over Ash Creek, approximately 2.2 miles upstream of the site of the proposed pedestrian bridge. The information is included in the USGS publication, *Peak-Flow Frequency Estimates for U.S. Geological Survey Streamflow-Gaging Stations in Connecticut*. The peak-flow frequency estimates produced by the gage data are based on 24-years of water flow records between 1978 and 2001. At the gaging station, the river has a drainage area of 10.6 square miles. The flow estimates and drainage area are utilized with the transfer equation contained in the ConnDOT Drainage Manual to estimate flows at the proposed pedestrian bridge site. See Appendix B of this report for gage data information and the transfer flow calculations. The stream gage data flows will not be utilized for the hydraulic analysis.
3. **Method 3 – Urbanized USGS StreamStats:** StreamStats is a Web-based tool developed by the USGS and Environmental Systems Research Institute, Inc. (ESRI). This map-based Web application was designed to make it easy for users to obtain streamflow statistics, drainage-basin characteristics, and other information for user-selected sites. StreamStats utilizes previously published information from gaging stations and previously gathered basin characteristics to develop streamflow statistics utilizing the appropriate regression equations to compute the stream flows.

The StreamStats flows are based on characteristics of nonurban drainage basins. Due to urbanization of the watershed, the StreamStats flows have been adjusted using the seven-parameter regression equations included in the USGS publication, *Regression Equations for Estimating Flood Flows for the 2-, 10-, 25-, 50-, 100-, and 500-Year Recurrence Intervals in Connecticut*. See Appendix C of this report for the StreamStats Flow Statistics Report listing the basin characteristics and storm flows and the seven-parameter regression calculations. The Urbanized USGS StreamStats flows will be utilized for the hydraulic analysis.

The flows calculated using the methods mentioned above are listed in “Table 1: Summary of Flows” and shown on “Figure 1: Probability Chart for all Methods”.

IV. STUDY RESULTS

The Urbanized USGS StreamStats flows will be utilized as the design flows for the hydraulic analysis. A comparison of the flows shows the Urbanized USGS StreamStats flows and the FEMA Flood Insurance Study flows are similar, with the Transferred Gage Data flows being lower. The Urbanized USGS StreamStats flows were chosen since the flows are developed based on the characteristics of the watershed. The FEMA Flood Insurance Study flows were developed for the previous version of the FIS, dated September 6, 1989, and were not used due to the age of the data and since the 500-year event appears to overestimate flows. The Transferred Gage Data flows were discounted since these flows are based on 24 years of data and during this time (1978-2001), there were not any significant storm events. Additionally, the highly urbanized lower area of the watershed is not accounted for in the transferred gage calculations.

The FEMA 2-year and 25-year flows (which were not computed in the FIS) were estimated using Figure 1.

TABLE 1: SUMMARY OF FLOWS (C.F.S.)

Summary of Flows (cfs) vs. Design Frequency (years) Pedestrian Bridge over Ash Creek – Bridgeport, CT			
Year	FEMA Flood Insurance Study	Transferred Gage Data	Urbanized USGS StreamStats
2	920	1,270	1,100
10	1,625	2,000	2,060
25	2,200	2,300	2,580
50	2,750	2,500	3,060
100	3,700	2,680	3,630
500	6,250	3,040	4,300

FIGURE 1: PROBABILITY CHART FOR ALL METHODS

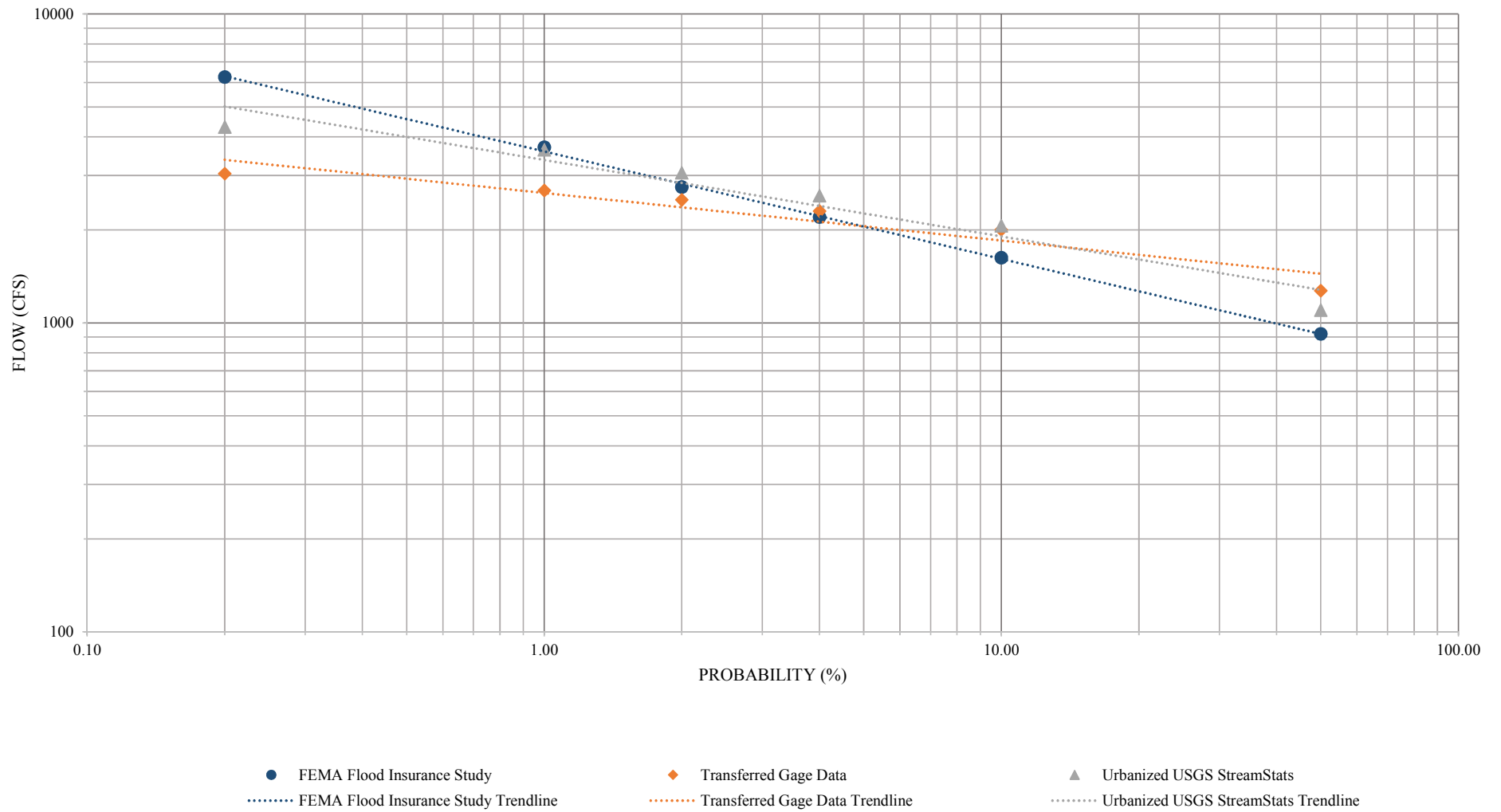

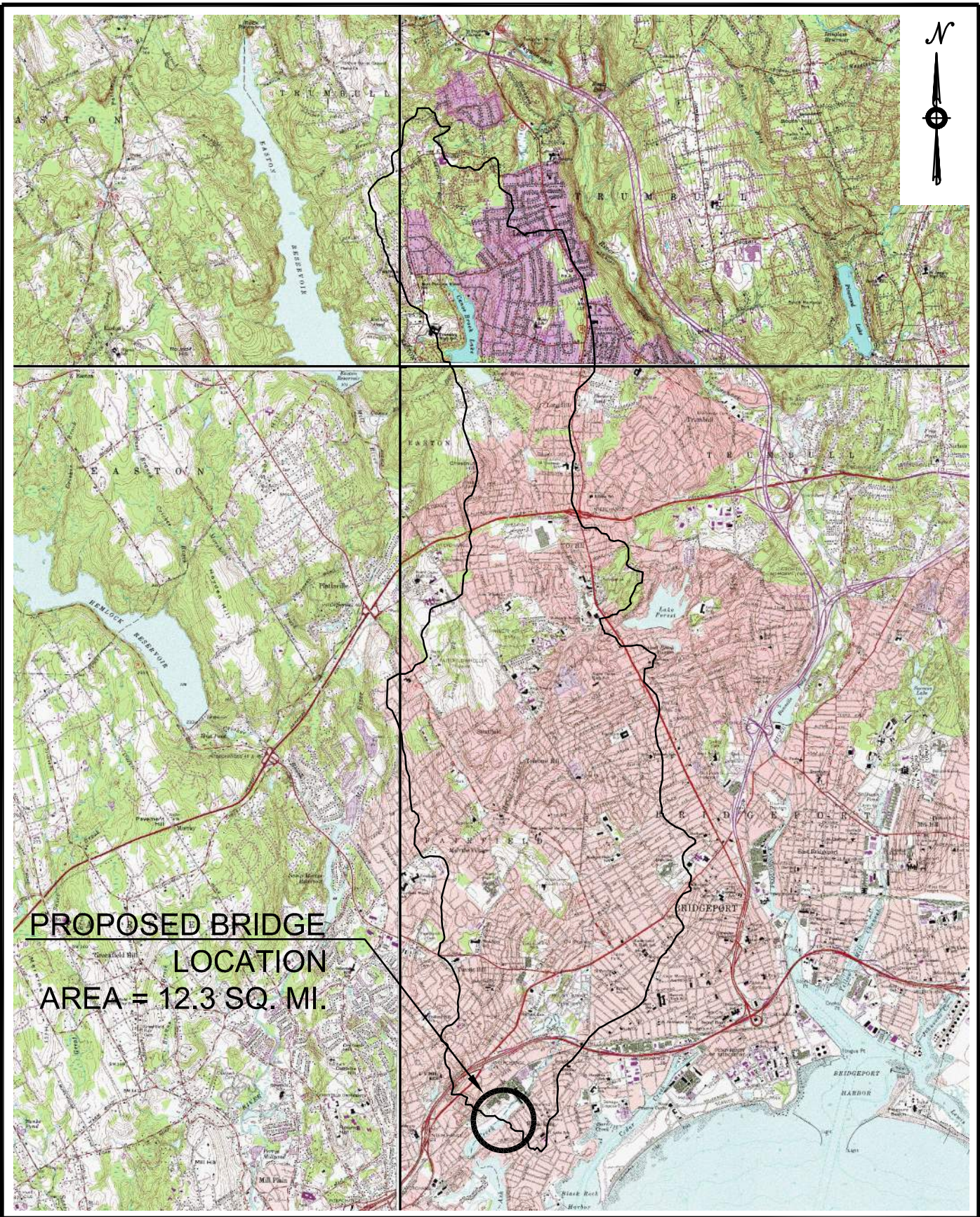

PEDESTRIAN BRIDGE
OVER
ASH CREEK
BRIDGEPORT, CT

WATERSHED AREA
MAP

FIGURE NO.: 2

SCALE: 1" = 6,000'

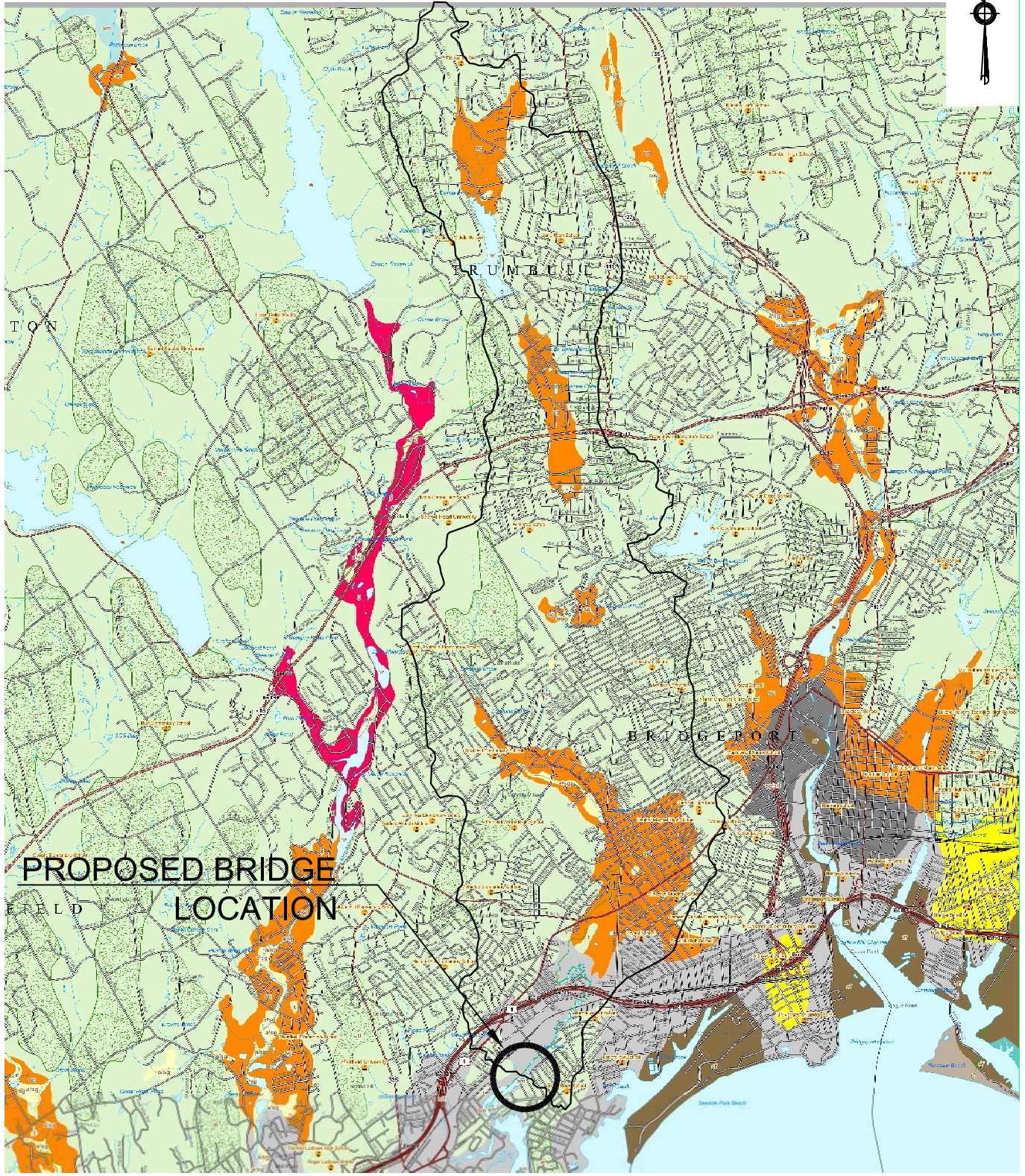

PEDESTRIAN BRIDGE
OVER
ASH CREEK
BRIDGEPORT, CT

SURFICIAL MATERIALS
MAP

FIGURE NO.: 3

SCALE: 1" = 6,000'

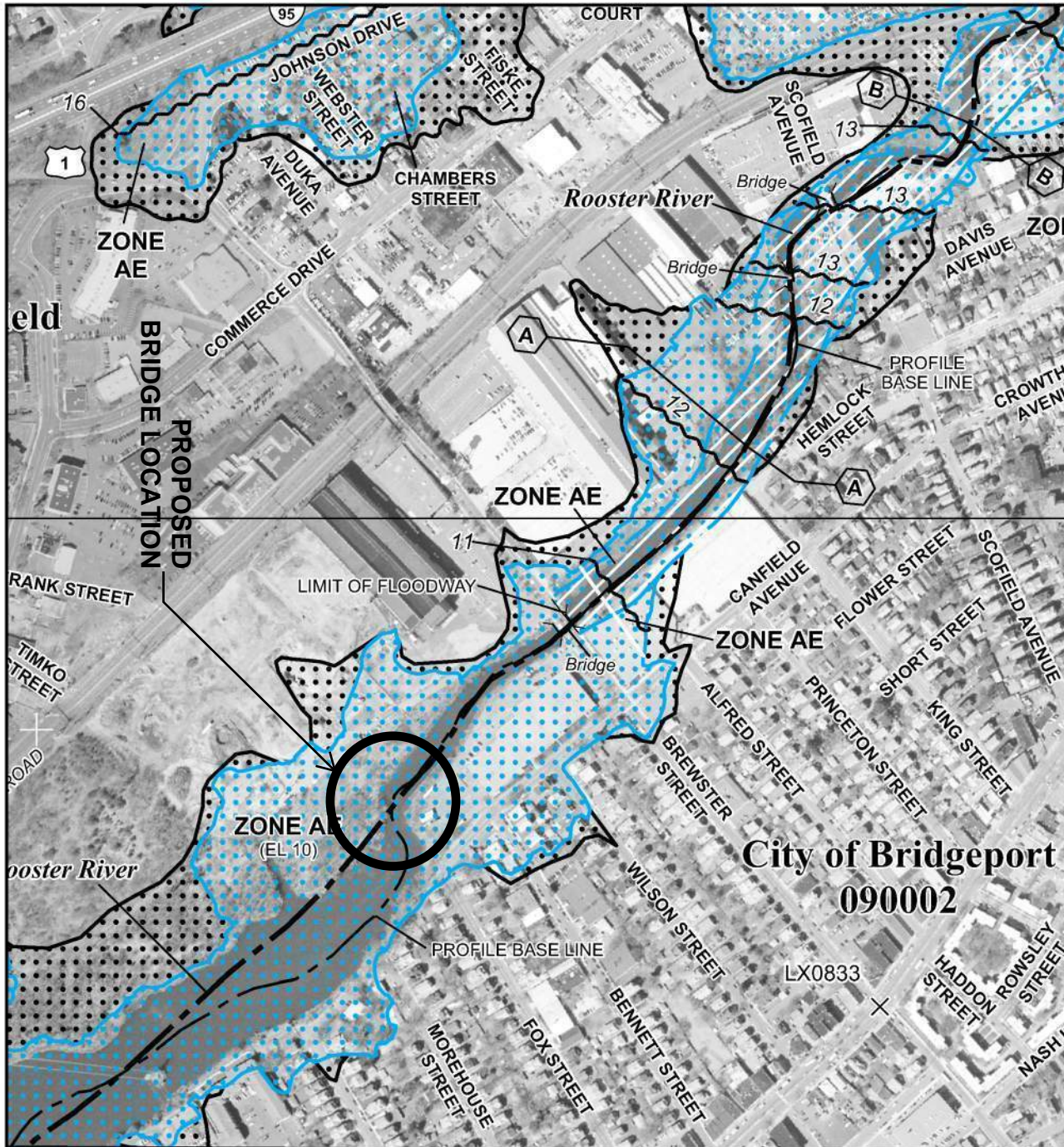

JOINS PANEL 0438



MAP SCALE 1" = 500'

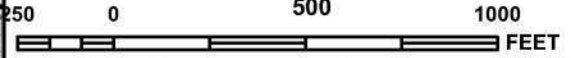

NATIONAL FLOOD INSURANCE PROGRAM

PANEL 0436G

FIRM
FLOOD INSURANCE RATE MAP
FAIRFIELD COUNTY,
CONNECTICUT
 (ALL JURISDICTIONS)

PANEL 436 OF 626
 (SEE MAP INDEX FOR FIRM PANEL LAYOUT)

CONTAINS:

COMMUNITY	NUMBER	PANEL	SUFFIX
BRIDGEPORT, CITY OF	090002	0436	G
FAIRFIELD, TOWN OF	090007	0436	G

Notice to User: The **Map Number** shown below should be used when placing map orders; the **Community Number** shown above should be used on insurance applications for the subject community.



MAP NUMBER
 09001C0436G
MAP REVISED
 JULY 8, 2013

Federal Emergency Management Agency

This is an official copy of a portion of the above referenced flood map. It was extracted using F-MIT On-Line. This map does not reflect changes or amendments which may have been made subsequent to the date on the title block. For the latest product information about National Flood Insurance Program flood maps check the FEMA Flood Map Store at www.msc.fema.gov

FIGURE NO. : 4

APPENDICES

INPUT DATA & CALCULATIONS

Appendix A: Method 1 – FEMA FIS Flows

- Portions of the Fairfield County Flood Insurance Study

Appendix B: Method 2 – Transferred Gage Data

- USGS Stream Gage Flows
- Transferred Gage Calculation

Appendix C: Method 3 – Urbanized USGS StreamStats

- USGS StreamStats Flow Statistics Report
- Atlas 14 Rainfall Data
- Flow Urbanization Calculations

APPENDIX A: METHOD 1 – FEMA FIS FLOWS

- **Portions of the Fairfield County Flood Insurance Study**

FLOOD INSURANCE STUDY

VOLUME 1 OF 6



FAIRFIELD COUNTY, CONNECTICUT (ALL JURISDICTIONS)

COMMUNITY NAME	COMMUNITY NUMBER
BETHEL, TOWN OF	090001
BRIDGEPORT, CITY OF	090002
BROOKFIELD, TOWN OF	090003
DANBURY, CITY OF	090004
DARIEN, TOWN OF	090005
EASTON, TOWN OF	090006
FAIRFIELD, TOWN OF	090007
GREENWICH, TOWN OF	090008
MONROE, TOWN OF	090009
NEW CANAAN, TOWN OF	090010
NEW FAIRFIELD, TOWN OF	090188
NEWTOWN, TOWN OF	090011
NORWALK, CITY OF	090012
REDDING, TOWN OF	090141
RIDGEFIELD, TOWN OF	090013
SHELTON, CITY OF	090014
SHERMAN, TOWN OF	090166
STAMFORD, CITY OF	090015
STRATFORD, TOWN OF	090016
TRUMBULL, TOWN OF	090017
WESTON, TOWN OF	090018
WESTPORT, TOWN OF	090019
WILTON, TOWN OF	090020

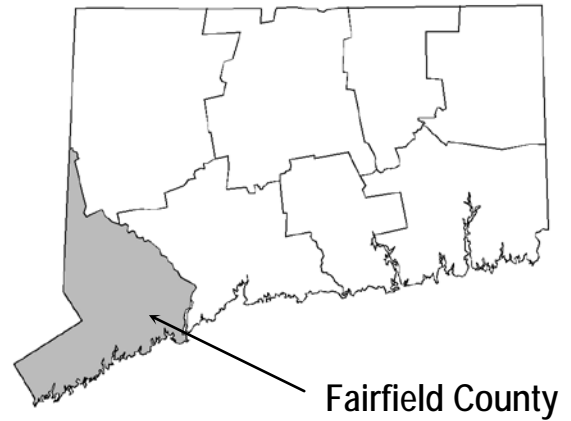

Revised:
October 16, 2013



Federal Emergency Management Agency

FLOOD INSURANCE STUDY NUMBER
09001CV001C

Bridgeport, City of: - continued	<p>under Contract No. H-4560. The work for the original analyses was completed in September 1978.</p> <p>The hydrologic and hydraulic analyses for the Rooster River for the FIS report dated September 6, 1989 were prepared by FGA Services, Inc. The work for that revision was completed in September 1988.</p>
Brookfield, Town of:	<p>The hydrologic and hydraulic analyses from the FIS report dated December 1978 were performed by Harris-Toups Associates for the Federal Insurance Administration (FIA), under Contract No. H-3987. That work, which was completed in October 1977, covered all significant flooding sources affecting the Town of Brookfield.</p>
Danbury, City of:	<p>The hydrologic and hydraulic analyses from the FIS report dated April 1982 were performed by Anderson-Nichols & Company, Inc., for the FIA, under Contract No. H-3707. That work, which was completed in March 1976, covered all flooding sources affecting the City of Danbury.</p>
Darien, Town of:	<p>The hydrologic and hydraulic analyses from the original FIS report were prepared by CE Maguire, Inc., for FEMA under Contract No. H-4560. That work was completed in August 1978.</p> <p>The effects of wave action for Long Island Sound for the FIS report dated May 17, 1982 were prepared by Dewberry & Davis. The hydrologic and hydraulic analyses for that revision were taken from the FIS for the City of Stamford, which was prepared by the USACE, New England District, for FEMA, under Inter-Agency Agreement No. EMW-E-0941 (FEMA, 1984). That work was completed in May 1990.</p>
Easton, Town of:	<p>The hydrologic and hydraulic analyses from the FIS report dated March 30, 1983, were performed by CE Maguire, Inc., for FEMA, under Contract No. EMW-C-0278. That work was completed in September 1981.</p>
Fairfield, Town of:	<p>The hydrologic and hydraulic analyses from the original August 19, 1986, FIS report were performed by the USACE, New England Division, under Inter-Agency Agreement No. IAA-H-19-74, Project Order</p>

Pre-countywide Analyses

In the Town of Bethel, the discharges for Limekiln Brook 2 and Sympaug Brook were taken directly from the FIS for the City of Danbury (Reference 40).

The Regional Frequency Method (Reference 41) was used for computing peak discharges for East Swamp, Terehaute, Wolf Pit, Dibbles, and Putnam Park Brooks. This method is based on a regression analysis of stream flow records from 105 stream-gaging stations in Connecticut and 28 precipitation-gaging stations established by the National Weather Service in Connecticut, Massachusetts, Rhode Island, and New York.

The regional analysis is based on the parameters of drainage area, rainfall, main channel length, main channel slope, and extent of storm sewers.

The discharges were transposed to various points on the streams using the relationship:

$$\frac{Q_1}{Q_2} = \frac{A_1 \left(\frac{.894}{A_1 .048} \right)}{A_2 \left(\frac{.894}{A_2 .048} \right)}$$

Where Q_1 and Q_2 are discharges at the calculated point and at the mouth of the study stream, respectively, and A_1 and A_2 are the respective drainage areas at the aforementioned locations (Reference 42).

In the City of Bridgeport, peak discharges for Island Brook, Yellow Mill Channel, Horse Tavern Brook, and the Rooster River were computed for the 10-, 2-, 1-, and 0.2-percent-annual-chance floods using the Regional Frequency Method (Reference 41). For Island Brook and Yellow Mill Channel, these discharges were compared to those obtained from the rainfall-runoff technique based on the Synthetic Triangular Unit Hydrograph, and from NRCS methods (References 43 through 46). A smooth curve was plotted from the three sets of values and the final discharges were taken from the curve. For Horse Tavern Brook and the Rooster River, the discharges compared favorably with those in the regional discharge-frequency curves published in the FIS for the Town of Fairfield (Reference 47); therefore, the values from the Fairfield study were adopted. For the revised portion of the Rooster River, the flood frequency-discharge values from the original study were redistributed between the new conduit and the old channel to reflect the improvements.

Peak discharges for the Pequonnock River (Upper Reach) and Pequonnock River (Lower Reach) were similarly computed and were compared with those published in the FIS for the Town of Trumbull (Reference 48). The discharges at the upstream corporate limits compared favorably, and the published discharges were adopted. These discharges were adjusted in the downstream portions by a method developed by the NRCS using discharge-area relationships (Reference 42). Peak discharges for Bruce Brook were adopted from the FIS for the Town of Stratford (Reference 49).

TABLE 5 - SUMMARY OF DISCHARGES - continued

<u>FLOODING SOURCE AND LOCATION</u>	<u>DRAINAGE AREA (sq. miles)</u>	<u>PEAK DISCHARGES (cfs)</u>			
		<u>10- PERCENT- ANNUAL- CHANCE</u>	<u>2- PERCENT- ANNUAL- CHANCE</u>	<u>1- PERCENT- ANNUAL- CHANCE</u>	<u>0.2- PERCENT- ANNUAL- CHANCE</u>
ROCKWOOD LAKE BROOK					
At mouth above Greenwich Creek	4.0	314	413	512	930
Above unnamed pond at Latitude N 41°-04'- 06"	3.5	276	362	449	815
Above Bolling Pond	2.9	224	294	364	662
ROOSTER RIVER					
Downstream of Railroad	11.52	1,625	2,750	3,700	6,250
Downstream of Kings Highway East	10.53	1,600	2,600	3,500	5,900
At mouth	9.48	1,500	2,450	3,100	5,400
At Bridgeport-Fairfield corporate limits	7.60	1,225	2,000	2,575	4,350
At Bridgeport-Fairfield corporate limits, downstream of Stratfield Road	7.6	1,300	2,100	2,700	4,500
SASCO CREEK					
At mouth near Long Island Sound	10.2	1,560	2,500	3,170	5,360
Downstream of Sasco Pond Dam	8.6	1,430	2,300	2,900	4,920
At Hulls Farm Road	7.3	1,350	2,100	2,600	4,300
Above confluence of Great Brook	5.7	1,150	1,750	2,100	3,500
At Silver Spring Road	5.4	1,100	1,700	2,000	3,300
Above confluence of unnamed brook at Greenfield Hill	2.0	610	820	900	1,400
SAUGATUCK RIVER (LOWER REACH)					
At Lee Pond Dam	81.0	4,500	9,200	12,600	24,800
Upstream of confluence of West Branch Saugatuck River	67.7	4,000	8,180	11,200	22,060
At reservoir entrance	20.8	1,560	2,930	3,740	5,920

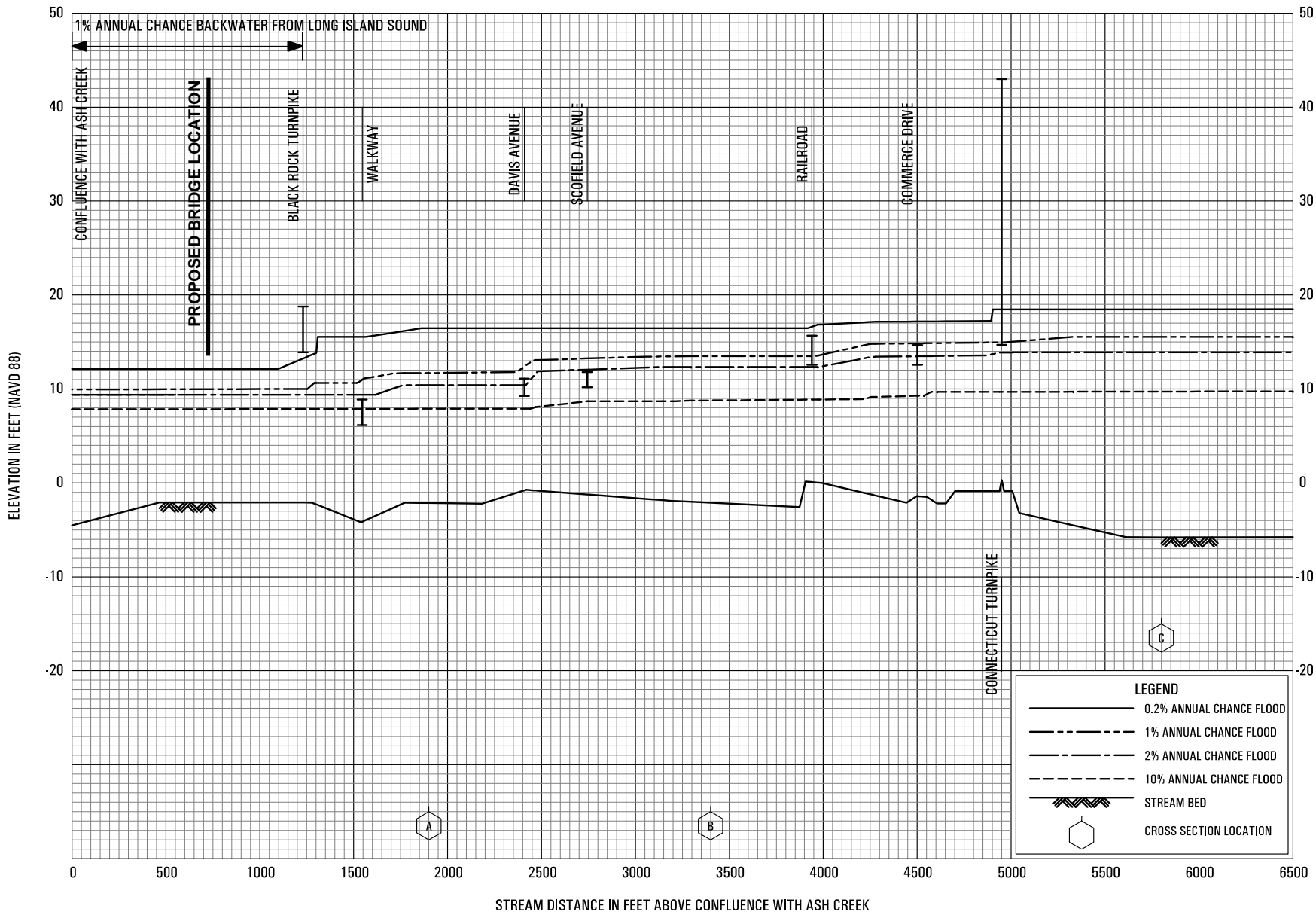

FLOOD PROFILES

ROOSTER RIVER

FEDERAL EMERGENCY MANAGEMENT AGENCY
FAIRFIELD COUNTY, CT
 ALL JURISDICTIONS

APPENDIX B: METHOD 2 – TRANSFERRED GAGE DATA

- **USGS Stream Gage Flows**
- **Transferred Gage Calculation**

Table 1. Peak-flow frequency estimates for streams in Connecticut for selected recurrence intervals--Continued

[Peak-flow frequency estimates are based on 10 or more years of unregulated flow record. Period of record includes historical information outside the period of systematic data collection at or near a gaging station. Period of record in italics represents the period when flows were affected by flood-control regulation. regulated, flood-control reservoir affects flow (regulated indicates that the drainage area upstream from the gaging station has more than 4.5 million cubic feet of usable storage per mile (Benson, 1962)); mi², square miles; ft³/s, cubic feet per second; nr, near; rev, revised; e, estimated]

U.S. Geological Survey streamflow-gaging station		Drainage area (mi ²)	Period of record (water years)	Peak-flow frequency estimates for given recurrence interval (ft ³ /s)						Maximum known peak flow		
Number	Name			1.5 years	2 years	10 years	25 years	50 years	100 years	500 years	Date	Flow (ft ³ /s)
01206900	Naugatuck River at Thomaston (regulated)	99.8	1955, <i>1960-2001</i>	Less than 10 years of unregulated flow						08/19/1955	53,400	
01208013	Branch Brook nr Thomaston (regulated)	20.8	1971-2001, <i>1920-1940</i>	Entire period of record regulated for flood control						06/08/1982	805	
01208100	Hancock Brook nr Terryville	1.18	1960-1981	95	118	219	274	315	357	459	09/26/1975	300
01208400	Hop Brook nr Middlebury	9.43	1955, 1962-1975	333	436	1,050	1,480	1,870	2,310	3,610	08/19/1955	1,700
01208420	Hop Brook nr Naugatuck (regulated)	16.3	1955, <i>1970-2001</i>	Less than 10 years of unregulated flow						08/19/1955	2,650	
01208500	Naugatuck River at Beacon Falls (regulated)	260	1920-1959, <i>1960-2001</i>	6,700	8,620	20,700	29,900	38,400	48,500	80,200	08/19/1955	106,000
01208700	Little River at Oxford	4.54	1960-1984	186	243	600	870	1,120	1,420	2,340	06/05/1982	1,350
SOUTHWEST COASTAL BASINS												
01208850	Pequonnock River at Trumbull	15.6	1955, 1962-1984	555	732	1,720	2,380	2,950	3,580	5,340	10/16/1955	e 4,500
01208873	Rooster River at Fairfield ³	10.6	1978-2001	959	1,140	1,800	2,070	2,250	2,410	2,740	04/09/1980	2,170
01208900	Patterson Brook nr Easton	1.21	1960-1984	61	72	116	139	156	173	214	06/05/1982	148
01208925	Mill River nr Fairfield	28.6	1973-2001	507	679	1,530	2,020	2,390	2,780	3,740	04/10/1980	1,800
01208950	Sasco Brook nr Southport	7.38	1960-2001	205	270	728	1,120	1,500	1,970	3,580	06/19/1972	1,640
01208990	Saugatuck River nr Redding	21.0	1962-2001	456	586	1,220	1,580	1,860	2,160	2,900	03/25/1969	1,860
01209500	Saugatuck River nr Westport	79.8	1933-1967	1,140	1,540	3,950	5,680	7,220	8,990	14,200	10/16/1955	14,800
01209600	Comstock Brook at N Wilton	3.50	1960-1975	116	137	251	325	388	459	659	09/26/1975	440
01209700	Norwalk River at S Wilton	30.0	1956, 1963-2001	778	1,010	2,320	3,220	4,000	4,880	7,390	10/16/1955	e 12,000
01209770	Fivemile River nr Norwalk	8.96	1956, 1962-1984	431	536	1,130	1,540	1,890	2,300	3,470	10/16/1955	e 3,250
01211700	E Branch Byram River at Round Hill	1.69	1960-1975	78	100	225	306	376	452	663	06/19/1972	245
01212100	E Branch Byram River at Riversville	11.1	1963-1984	409	567	1,450	2,020	2,490	3,000	4,340	06/19/1972	1,700

¹Peak flow for these water years is a maximum daily average.

²Gaging station formerly published under the name West Branch Salmon Brook at Granby, Connecticut.

³Discharge is affected by urbanization or channelization.

⁴1995–98 streamflow data collected at station 01192704, Mattabeset River at Rt. 372 at East Berlin adjusted to site (data transferred using transfer equation 6.12, Drainage Manual, Connecticut Dept. of Transportation, January 2000).

⁵1962–80 streamflow data collected at station 01192890, Coginchaug River at Rockfall adjusted to site (data transferred using transfer equation 6.12, Drainage Manual, Connecticut Dept. of Transportation, January 2000).

⁶Peak flow affected by dam break.

⁷1967–84 streamflow data collected at station 01201510, Still River at Lanesville adjusted to site (data transferred using transfer equation 6.12, Drainage Manual, Connecticut Dept. of Transportation, January 2000).

⁸Peak-flow frequency estimates based on water years 1972–81.

⁹1960–84 streamflow data collected at station 01206400, Leadmine Brook near Harwinton adjusted to site (data transferred using transfer equation 6.12, Drainage Manual, Connecticut Dept. of Transportation, January 2000).

¹⁰Peak flow augmented by release of storage from dam failure.

¹¹Peak flow affected by dam failures.



150 Trumbull Street, 6th Floor
Hartford, Connecticut 06103

PROJECT: Pedestrian Bridge over Ash Creek
Bridgeport, CT

PREPARED BY David Cicia DATE 9/28/16
CHECKED BY Aaron Foster DATE 10/3/16

TRANSFERRED GAGE CALCULATION
Pedestrian Bridge over Ash Creek

USGS Streamflow Gaging Station Data

	Drainage Area (sq. mi.)	Peak Discharges (cfs)					
		2-Year	10-Year	25-Year	50-Year	100-Year	500-Year
Gage 01208873							
Rooster River at Fairfield	10.6	1140	1800	2070	2250	2410	2740

BRIDGE LOCATION

Near Morehouse Street 12.3

APPLICABLE USE

The drainage area at the bridge must be >75% and <125% of the drainage area at the location of the known flow.

$$12.3/10.6 = 116.0\% \quad \text{OK to use}$$

TRANSFER EQUATION

From SCS National Engineering Handbook, Section 4

$$\frac{Q_1}{A_1} = \frac{A_1^{[(0.894 / A_1^{(0.048)}) - 1]}}{A_2^{[(0.894 / A_2^{(0.048)}) - 1]}}$$

TRANSFERRED FLOWS

	$Q_1 =$ Transferred Flows (cfs)					
	2-Year	10-Year	25-Year	50-Year	100-Year	500-Year
$Q_2 =$ Flow, Shown Above	1270	2000	2300	2500	2680	3040

$A_2 =$ 10.6 sq. mi.

$A_1 =$ 12.3 sq. mi.

$Q_1 =$ Flow at the Proposed Bridge Site

APPENDIX C: METHOD 3 – URBANIZED USGS STREAMSTATS

- **USGS StreamStats Flow Statistics Report**
- **Atlas 14 Rainfall Data**
- **Flow Urbanization Calculations**

StreamStats Version 3.0

Flow Statistics Ungaged Site Report

Date: Tues Sept 27, 2016 3:57:30 PM GMT-4

Study Area: Connecticut

NAD 1983 Latitude: 41.1581 (41 09 29)

NAD 1983 Longitude: -73.2321 (-73 13 56)

Drainage Area: 12.3 mi²

Peak Flows Region Grid Basin Characteristics			
100% Statewide Multiparameter (12.3 mi ²)			
Parameter	Value	Regression Equation Valid Range	
		Min	Max
Drainage Area (square miles)	12.3	1.69	715
24 Hour 2 Year Precipitation (inches)	3.602	2.95	3.82
24 Hour 10 Year Precipitation (inches)	5.356	4.15	5.53
24 Hour 25 Year Precipitation (inches)	6.727	4.93	7
24 Hour 50 Year Precipitation (inches)	7.994	5.62	8.36
24 Hour 100 Year Precipitation (inches)	9.512	6.41	9.99
Mean Basin Elevation (feet)	222	169	1310

SALMONID SPAWNING Basin Characteristics			
100% Duration Flow 2010 5052 (12.3 mi ²)			
Parameter	Value	Regression Equation Valid Range	
		Min	Max
Drainage Area (square miles)	12.3	0.92	150
Mean November Precipitation (inches)	4.3	3.48	4.93
Percent Coarse Stratified Drift (percent)	14.7	0.1	55.1
Mean Annual Winter Precipitation (inches)	3.7	3.19	4.4
Percent Wetlands (percent)	0.16 (below min value 0.3)	0.3	18.1
Mean Basin Elevation (feet)	222	168	1287

Warning: Some parameters are outside the suggested range. Estimates will be extrapolations with unknown errors.

OVERWINTER Basin Characteristics			
100% Duration Flow 2010 5052 (12.3 mi ²)			
Parameter	Value	Regression Equation Valid Range	
		Min	Max
Drainage Area (square miles)	12.3	0.92	150
Mean November Precipitation (inches)	4.3	3.48	4.93
Percent Coarse Stratified Drift (percent)	14.7	0.1	55.1
Mean Annual Winter Precipitation (inches)	3.7	3.19	4.4

Percent Wetlands (percent)	0.16 (below min value 0.3)	0.3	18.1
Mean Basin Elevation (feet)	222	168	1287

Warning: Some parameters are outside the suggested range. Estimates will be extrapolations with unknown errors.

HABITAT FORMING Basin Characteristics			
100% Duration Flow 2010 5052 (12.3 mi2)			
Parameter	Value	Regression Equation Valid Range	
		Min	Max
Drainage Area (square miles)	12.3	0.92	150
Mean November Precipitation (inches)	4.3	3.48	4.93
Percent Coarse Stratified Drift (percent)	14.7	0.1	55.1
Mean Annual Winter Precipitation (inches)	3.7	3.19	4.4
Percent Wetlands (percent)	0.16 (below min value 0.3)	0.3	18.1
Mean Basin Elevation (feet)	222	168	1287

Warning: Some parameters are outside the suggested range. Estimates will be extrapolations with unknown errors.

CLUPEID SPAWNING Basin Characteristics			
100% Duration Flow 2010 5052 (12.3 mi2)			
Parameter	Value	Regression Equation Valid Range	
		Min	Max
Drainage Area (square miles)	12.3	0.92	150
Mean November Precipitation (inches)	4.3	3.48	4.93
Percent Coarse Stratified Drift (percent)	14.7	0.1	55.1
Mean Annual Winter Precipitation (inches)	3.7	3.19	4.4
Percent Wetlands (percent)	0.16 (below min value 0.3)	0.3	18.1
Mean Basin Elevation (feet)	222	168	1287

Warning: Some parameters are outside the suggested range. Estimates will be extrapolations with unknown errors.

RESIDENT SPAWNING Basin Characteristics			
100% Duration Flow 2010 5052 (12.3 mi2)			
Parameter	Value	Regression Equation Valid Range	
		Min	Max
Drainage Area (square miles)	12.3	0.92	150
Mean November Precipitation (inches)	4.3	3.48	4.93
Percent Coarse Stratified Drift (percent)	14.7	0.1	55.1
Mean Annual Winter Precipitation (inches)	3.7	3.19	4.4

Percent Wetlands (percent)	0.16 (below min value 0.3)	0.3	18.1
Mean Basin Elevation (feet)	222	168	1287

Warning: Some parameters are outside the suggested range. Estimates will be extrapolations with unknown errors.

REARING AND GROWTH Basin Characteristics			
100% Duration Flow 2010 5052 (12.3 mi2)			
Parameter	Value	Regression Equation Valid Range	
		Min	Max
Drainage Area (square miles)	12.3	0.92	150
Mean November Precipitation (inches)	4.3	3.48	4.93
Percent Coarse Stratified Drift (percent)	14.7	0.1	55.1
Mean Annual Winter Precipitation (inches)	3.7	3.19	4.4
Percent Wetlands (percent)	0.16 (below min value 0.3)	0.3	18.1
Mean Basin Elevation (feet)	222	168	1287

Warning: Some parameters are outside the suggested range. Estimates will be extrapolations with unknown errors.

Period-of-Record Basin Characteristics			
100% Duration Flow 2010 5052 (12.3 mi2)			
Parameter	Value	Regression Equation Valid Range	
		Min	Max
Drainage Area (square miles)	12.3	0.92	150
Mean November Precipitation (inches)	4.3	3.48	4.93
Percent Coarse Stratified Drift (percent)	14.7	0.1	55.1
Mean Annual Winter Precipitation (inches)	3.7	3.19	4.4
Percent Wetlands (percent)	0.16 (below min value 0.3)	0.3	18.1
Mean Basin Elevation (feet)	222	168	1287

Warning: Some parameters are outside the suggested range. Estimates will be extrapolations with unknown errors.

Peak Flows Region Grid Statistics						
Statistic	Value	Unit	Prediction Error (percent)	Equivalent years of record	90-Percent Prediction Interval	
					Min	Max
PK2	408	ft3/s	32	3.5		
PK10	943	ft3/s	33	8.1		
PK25	1290	ft3/s	34	11		
PK50	1580	ft3/s	36	13		
PK100	1880	ft3/s	38	14		
PK500	2340	ft3/s	45	15		

<http://water.usgs.gov/pubs/sir/2004/5160/> (<http://water.usgs.gov/pubs/sir/2004/5160/>)

Ahearn_ E.A._ 2004_ Regression Equations for Estimating Flood Flows for the 2-_ 10-_ 25-_ 50-_ 100-_ and 500-Year Recurrence Intervals in Connecticut: U.S. Geological Survey SRI 2004-5160_ 62 p.

SALMONID SPAWNING Statistics						
Statistic	Value	Unit	Prediction Error (percent)	Equivalent years of record	90-Percent Prediction Interval	
					Min	Max
NOVD25	24.1	ft3/s				
NOVD50	12.7	ft3/s				
NOVD75	6.07	ft3/s				
NOVD90	3.06	ft3/s				
NOVD99	1.2	ft3/s				

<http://pubs.usgs.gov/sir/2010/5052/> (<http://pubs.usgs.gov/sir/2010/5052/>)

Ahearn_ E.A._ 2010_ Regional regression equations to estimate flow-duration statistics in Connecticut: U. S. Geological Survey Scientific Investigations Report 2010-5052_ 45 p.

OVERWINTER Statistics						
Statistic	Value	Unit	Prediction Error (percent)	Equivalent years of record	90-Percent Prediction Interval	
					Min	Max
D25 12 02	29.6	ft3/s				
D50 12 02	17.4	ft3/s				
D75 12 02	10.3	ft3/s				
D95 12 02	4.57	ft3/s				
D99 12 02	2.26	ft3/s				

<http://pubs.usgs.gov/sir/2010/5052/> (<http://pubs.usgs.gov/sir/2010/5052/>)

Ahearn_ E.A._ 2010_ Regional regression equations to estimate flow-duration statistics in Connecticut: U. S. Geological Survey Scientific Investigations Report 2010-5052_ 45 p.

HABITAT FORMING Statistics						
Statistic	Value	Unit	Prediction Error (percent)	Equivalent years of record	90-Percent Prediction Interval	
					Min	Max
D25 03 04	52.1	ft3/s				
D50 03 04	33.4	ft3/s				
D75 03 04	23.6	ft3/s				
D95 03 04	14.1	ft3/s				
D99 03 04	10.1	ft3/s				

<http://pubs.usgs.gov/sir/2010/5052/> (<http://pubs.usgs.gov/sir/2010/5052/>)

Ahearn_ E.A._ 2010_ Regional regression equations to estimate flow-duration statistics in Connecticut: U. S. Geological Survey Scientific Investigations Report 2010-5052_ 45 p.

CLUPEID SPAWNING Statistics						
Statistic	Value	Unit	Prediction Error (percent)	Equivalent years of record	90-Percent Prediction Interval	
					Min	Max
MAYD25	34	ft3/s				
MAYD50	23	ft3/s				
MAYD75	16	ft3/s				
MAYD95	9.2	ft3/s				
MAYD99	6.4	ft3/s				

<http://pubs.usgs.gov/sir/2010/5052/> (<http://pubs.usgs.gov/sir/2010/5052/>)

Ahearn_ E.A._ 2010_ Regional regression equations to estimate flow-duration statistics in Connecticut: U. S. Geological Survey Scientific Investigations Report 2010-5052_ 45 p.

RESIDENT SPAWNING Statistics						
Statistic	Value	Unit	Prediction Error (percent)	Equivalent years of record	90-Percent Prediction Interval	
					Min	Max
JUND25	14	ft3/s				
JUND50	7.81	ft3/s				
JUND75	4.33	ft3/s				
JUND90	4.28	ft3/s				
JUND99	2.11	ft3/s				

<http://pubs.usgs.gov/sir/2010/5052/> (<http://pubs.usgs.gov/sir/2010/5052/>)

Ahearn_ E.A._ 2010_ Regional regression equations to estimate flow-duration statistics in Connecticut: U. S. Geological Survey Scientific Investigations Report 2010-5052_ 45 p.

REARING AND GROWTH Statistics						
Statistic	Value	Unit	Prediction Error (percent)	Equivalent years of record	90-Percent Prediction Interval	
					Min	Max
D25 07 10	8.65	ft3/s				
D50 07 10	4.16	ft3/s				
D75 07 10	2.17	ft3/s				
D80 07 10	1.86	ft3/s				
D99 07 10	0.41	ft3/s				

<http://pubs.usgs.gov/sir/2010/5052/> (<http://pubs.usgs.gov/sir/2010/5052/>)

Ahearn_ E.A._ 2010_ Regional regression equations to estimate flow-duration statistics in Connecticut: U. S. Geological Survey Scientific Investigations Report 2010-5052_ 45 p.

Period-of-Record Statistics						

Statistic	Value	Unit	Prediction Error (percent)	Equivalent years of record	90-Percent Prediction Interval	
					Min	Max
D25	32.3	ft ³ /s				
D99	0.72	ft ³ /s				

<http://pubs.usgs.gov/sir/2010/5052/> (<http://pubs.usgs.gov/sir/2010/5052/>)

Ahearn_ E.A._ 2010_ Regional regression equations to estimate flow-duration statistics in Connecticut: U. S. Geological Survey Scientific Investigations Report 2010-5052_ 45 p.

Accessibility

FOIA

Privacy

Policies and Notices

U.S. Department of the Interior | U.S. Geological Survey

URL: http://streamstatsags.cr.usgs.gov/v3_beta/FTreport.htm

Page Contact Information: [StreamStats Help](#)

Page Last Modified: 11/24/2015 15:32:58 (Web1)

[Streamstats Status](#)

[News](#)





NOAA Atlas 14, Volume 10, Version 2
Location name: Bridgeport, Connecticut, USA*
Latitude: 41.1573°, Longitude: -73.2302°
Elevation: 20.61 ft**
 * source: ESRI Maps
 ** source: USGS



POINT PRECIPITATION FREQUENCY ESTIMATES

Sanja Perica, Sandra Pavlovic, Michael St. Laurent, Carl Trypaluk, Dale Unruh, Orlan Wilhite
 NOAA, National Weather Service, Silver Spring, Maryland

[PF_tabular](#) | [PF_graphical](#) | [Maps & aeriels](#)

PF tabular

PDS-based point precipitation frequency estimates with 90% confidence intervals (in inches)¹										
Duration	Average recurrence interval (years)									
	1	2	5	10	25	50	100	200	500	1000
5-min	0.354 (0.281-0.440)	0.420 (0.333-0.523)	0.528 (0.418-0.660)	0.618 (0.486-0.777)	0.742 (0.562-0.971)	0.838 (0.620-1.12)	0.933 (0.668-1.29)	1.05 (0.710-1.48)	1.20 (0.780-1.76)	1.31 (0.832-1.96)
10-min	0.501 (0.398-0.623)	0.595 (0.472-0.741)	0.748 (0.592-0.935)	0.876 (0.688-1.10)	1.05 (0.797-1.38)	1.19 (0.879-1.58)	1.32 (0.947-1.83)	1.49 (1.01-2.10)	1.70 (1.10-2.49)	1.86 (1.18-2.78)
15-min	0.589 (0.468-0.733)	0.700 (0.555-0.871)	0.881 (0.696-1.10)	1.03 (0.810-1.29)	1.24 (0.937-1.62)	1.40 (1.03-1.86)	1.55 (1.11-2.15)	1.75 (1.18-2.47)	2.00 (1.30-2.93)	2.19 (1.39-3.27)
30-min	0.822 (0.653-1.02)	0.976 (0.775-1.22)	1.23 (0.971-1.53)	1.44 (1.13-1.80)	1.72 (1.31-2.25)	1.95 (1.44-2.60)	2.17 (1.55-2.99)	2.43 (1.65-3.44)	2.77 (1.80-4.06)	3.03 (1.92-4.53)
60-min	1.05 (0.838-1.31)	1.25 (0.994-1.56)	1.57 (1.25-1.97)	1.84 (1.45-2.31)	2.21 (1.68-2.89)	2.50 (1.85-3.33)	2.78 (1.99-3.83)	3.11 (2.11-4.40)	3.54 (2.30-5.19)	3.87 (2.45-5.78)
2-hr	1.36 (1.09-1.69)	1.63 (1.30-2.02)	2.07 (1.65-2.57)	2.44 (1.93-3.04)	2.94 (2.24-3.83)	3.33 (2.48-4.42)	3.72 (2.68-5.12)	4.20 (2.85-5.90)	4.83 (3.15-7.03)	5.32 (3.37-7.88)
3-hr	1.57 (1.26-1.94)	1.89 (1.52-2.33)	2.41 (1.93-2.98)	2.84 (2.26-3.53)	3.44 (2.63-4.46)	3.89 (2.91-5.16)	4.35 (3.15-5.97)	4.94 (3.36-6.91)	5.71 (3.73-8.27)	6.30 (4.01-9.30)
6-hr	1.98 (1.60-2.42)	2.39 (1.93-2.92)	3.06 (2.46-3.75)	3.61 (2.89-4.46)	4.38 (3.38-5.64)	4.97 (3.74-6.54)	5.55 (4.05-7.60)	6.34 (4.33-8.82)	7.37 (4.83-10.6)	8.15 (5.20-12.0)
12-hr	2.44 (1.99-2.96)	2.95 (2.40-3.58)	3.78 (3.06-4.61)	4.47 (3.60-5.48)	5.43 (4.21-6.95)	6.16 (4.67-8.06)	6.89 (5.06-9.38)	7.89 (5.42-10.9)	9.21 (6.05-13.2)	10.2 (6.53-14.9)
24-hr	2.84 (2.33-3.42)	3.47 (2.84-4.19)	4.50 (3.67-5.44)	5.35 (4.34-6.51)	6.53 (5.10-8.32)	7.43 (5.68-9.69)	8.34 (6.17-11.3)	9.63 (6.64-13.2)	11.4 (7.48-16.1)	12.6 (8.12-18.3)
2-day	3.16 (2.61-3.78)	3.93 (3.24-4.70)	5.18 (4.25-6.22)	6.22 (5.07-7.51)	7.65 (6.02-9.71)	8.75 (6.74-11.4)	9.85 (7.37-13.4)	11.6 (7.99-15.7)	13.8 (9.12-19.4)	15.5 (9.97-22.2)
3-day	3.41 (2.83-4.06)	4.25 (3.52-5.07)	5.63 (4.64-6.73)	6.76 (5.54-8.13)	8.33 (6.59-10.5)	9.54 (7.38-12.4)	10.7 (8.07-14.5)	12.6 (8.76-17.2)	15.1 (10.0-21.2)	17.0 (11.0-24.3)
4-day	3.66 (3.04-4.34)	4.54 (3.77-5.40)	5.99 (4.95-7.14)	7.19 (5.90-8.61)	8.84 (7.00-11.1)	10.1 (7.84-13.1)	11.4 (8.57-15.4)	13.4 (9.28-18.1)	16.0 (10.6-22.3)	18.0 (11.6-25.6)
7-day	4.37 (3.65-5.16)	5.32 (4.45-6.29)	6.88 (5.72-8.15)	8.17 (6.75-9.74)	9.95 (7.92-12.4)	11.3 (8.80-14.5)	12.7 (9.56-16.9)	14.7 (10.3-19.8)	17.4 (11.6-24.2)	19.5 (12.6-27.6)
10-day	5.06 (4.25-5.95)	6.06 (5.08-7.13)	7.68 (6.41-9.07)	9.03 (7.48-10.7)	10.9 (8.68-13.5)	12.3 (9.58-15.6)	13.7 (10.3-18.2)	15.8 (11.0-21.1)	18.5 (12.3-25.5)	20.5 (13.3-28.9)
20-day	7.14 (6.04-8.33)	8.24 (6.95-9.62)	10.0 (8.43-11.8)	11.5 (9.60-13.6)	13.6 (10.8-16.6)	15.1 (11.8-18.9)	16.7 (12.5-21.6)	18.6 (13.1-24.7)	21.2 (14.2-29.0)	23.1 (15.0-32.3)
30-day	8.86 (7.52-10.3)	10.0 (8.50-11.7)	11.9 (10.1-13.9)	13.5 (11.3-15.9)	15.7 (12.6-19.1)	17.4 (13.6-21.6)	19.1 (14.3-24.4)	20.9 (14.8-27.6)	23.3 (15.7-31.8)	25.2 (16.4-35.1)
45-day	11.0 (9.38-12.7)	12.3 (10.4-14.2)	14.3 (12.1-16.6)	16.0 (13.5-18.7)	18.3 (14.8-22.1)	20.1 (15.7-24.8)	21.9 (16.4-27.8)	23.7 (16.8-31.1)	26.0 (17.6-35.3)	27.8 (18.2-38.6)
60-day	12.8 (10.9-14.8)	14.1 (12.0-16.3)	16.3 (13.8-18.8)	18.0 (15.2-21.0)	20.5 (16.5-24.7)	22.4 (17.5-27.4)	24.3 (18.2-30.6)	26.0 (18.5-34.0)	28.3 (19.1-38.3)	30.0 (19.6-41.5)

¹ Precipitation frequency (PF) estimates in this table are based on frequency analysis of partial duration series (PDS). Numbers in parenthesis are PF estimates at lower and upper bounds of the 90% confidence interval. The probability that precipitation frequency estimates (for a given duration and average recurrence interval) will be greater than the upper bound (or less than the lower bound) is 5%. Estimates at upper bounds are not checked against probable maximum precipitation (PMP) estimates and may be higher than currently valid PMP values. Please refer to NOAA Atlas 14 document for more information.

[Back to Top](#)



100 Constitution Plaza, 10th Floor
Hartford, Connecticut 06103

PROJECT: Pedestrian Bridge over Ash Creek
Brigdeport, CT

PREPARED BY David Cicia DATE 9/28/16
CHECKED BY Aaron Foster DATE 10/3/16

HYDROLOGY - "7 VARIABLE USGS REGRESSION EQUATION METHOD"
Pedestrian Bridge over Ash Creek
Urbanization of USGS StreamStats Flows

A = WATERSHED AREA INFORMATION (SQ. MILES)

DRAINAGE AREA: 12.3 SQ. MILES

SL = MAIN CHANNEL SLOPE:

10% POINT IS AT 6030 FT. UPSTREAM FROM BRIDGE
85% POINT IS AT 51280 FT. UPSTREAM FROM BRIDGE

ELEVATION AT 10% POINT 10 FT.
ELEVATION AT 85% POINT 360 FT.

CORRESPONDING LENGTH = 75% OF TOTAL FLOW PATH 8.57 MILES

EFFECTIVE SLOPE = DIFFERENCE IN ELEV. DIVIDED BY CORRESPONDING LENGTH
EFFECTIVE SLOPE = 40.8 FT./MILE
MAXIMUM VALUE FOR EFFECTIVE SLOPE = 70.0 FT./MILE

R₂ = 2-HOUR 2-YEAR RAINFALL RATE FOR CT (INCHES)

R₂ = 1.63

ST = DRAINAGE BASIN STORAGE

TOTAL AREA OF STORAGE = 3265842 SQ.FT.

% OF TOTAL AREA = 0.95 %

BDF = BASIN DEVELOPMENT FACTOR

	CHANNEL MODIFICATIONS	CHANNEL LINING	STORM SEWERS	CURB AND GUTTER
UPPER THIRD	0	0	1	1
MIDDLE THIRD	0	0	1	1
LOWER THIRD	0	0	1	1

BDF = 6

IA = IMPERVIOUS AREA (%)

TOTAL AREA OF IMPERVIOUS = 1.7E+08 SQ.FT.

IA= 50.2 %

REFERENCES

NOAA Atlas 14

USGS Map Areas

"Regression Equation for estimating Flood Flows for the 2-,10-, 25-,50-,100-, and 500-Year Recurrence Intervals in CT"

USGS Map Areas



100 Constitution Plaza, 10th Floor
Hartford, Connecticut 06103

PROJECT: Pedestrian Bridge over Ash Creek
Brigdeport, CT

PREPARED BY David Cicia DATE 9/28/16
CHECKED BY Aaron Foster DATE 10/3/16

HYDROLOGY - "7 VARIABLE USGS REGRESSION EQUATION METHOD"
Pedestrian Bridge over Ash Creek
Urbanization of USGS StreamStats Flows

RQx = REGRESSION EQUATION FLOWS (CFS)

Q2 = 408 CFS
Q10 = 943 CFS
Q25 = 1290 CFS
Q50 = 1580 CFS
Q100 = 1880 CFS
Q500 = 2340 CFS

USGS StreamStats Flows

7 PARAMETERS NEEDED FOR REGRESSION EQUATION

Drainage Area = 12.3 Sq. Miles
Channel Slope= 40.8 ft/mi.
Rainfall (inches)= 1.6 inches
Drainage Basin Stor 1.0 %
Assigned BDF = 6
Impervious Area= 50.2 %
RQ2 Storm Flow = 408 CFS
RQ10 Storm Flow = 943 CFS
RQ25 Storm Flow = 1290 CFS
RQ50 Storm Flow = 1580 CFS
RQ100 Storm Flow = 1880 CFS
RQ500 Storm Flow = 2340 CFS

"Regression Equation for estimating Flood Flows for the 2-,10-, 25-,50-,100-, and 500-Year Recurrence Intervals in CT"

USGS 7 PARAMETER REGRESSION EQUATION FLOWS

UQ 2 = 1100 CFS
UQ 10 = 2060 CFS
UQ 25 = 2580 CFS
UQ 50 = 3060 CFS
UQ 100 = 3630 CFS
UQ 500 = 4300 CFS

APPENDIX B – CROSS-SECTION LOCATIONS & CROSS-SECTIONS



NOTE: SURVEY CROSS-SECTION GROUND POINTS USED TO PRODUCE SECTIONS OUTSIDE OF THE FIELD SURVEY



PEDESTRIAN BRIDGE
OVER
ASH CREEK
BRIDGEPORT, CT

HYDRAULIC
CROSS-SECTIONS

FIGURE NO.:

SCALE: 1" = 200'

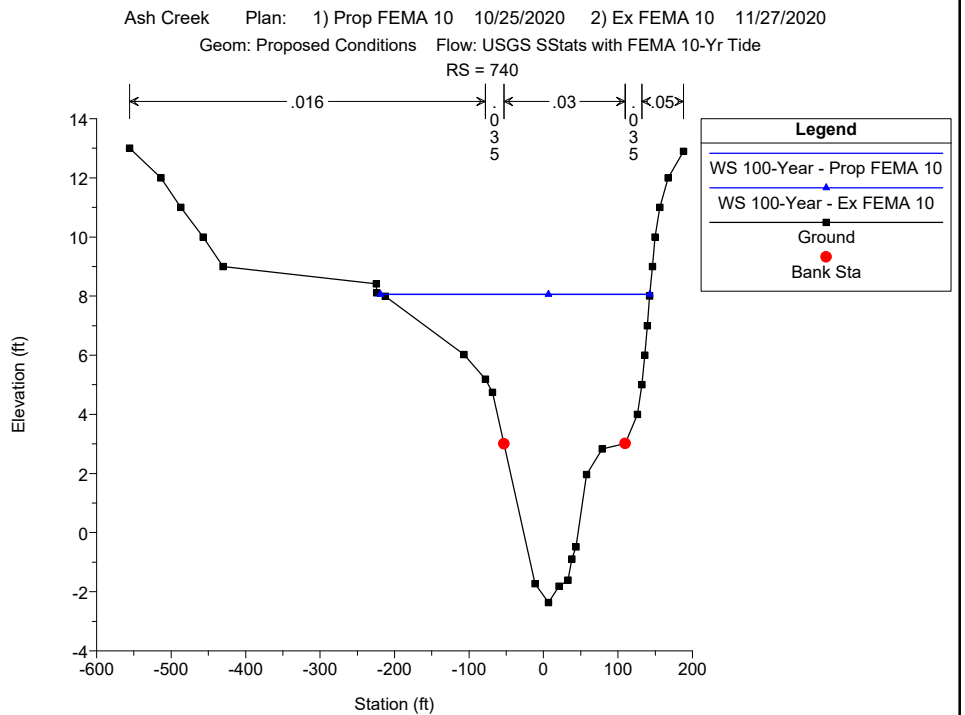
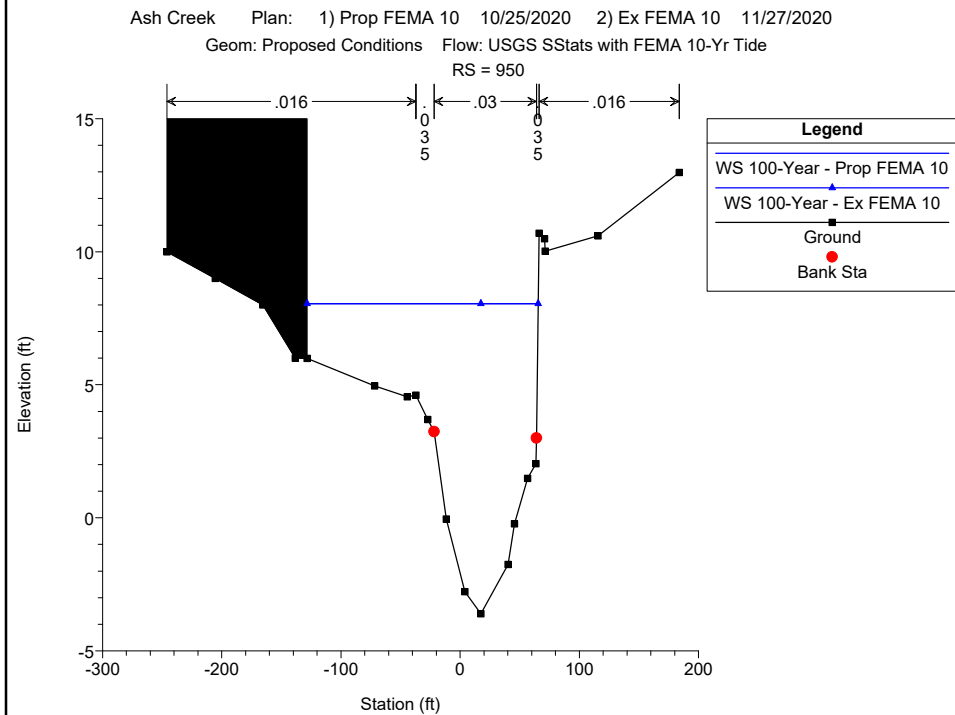
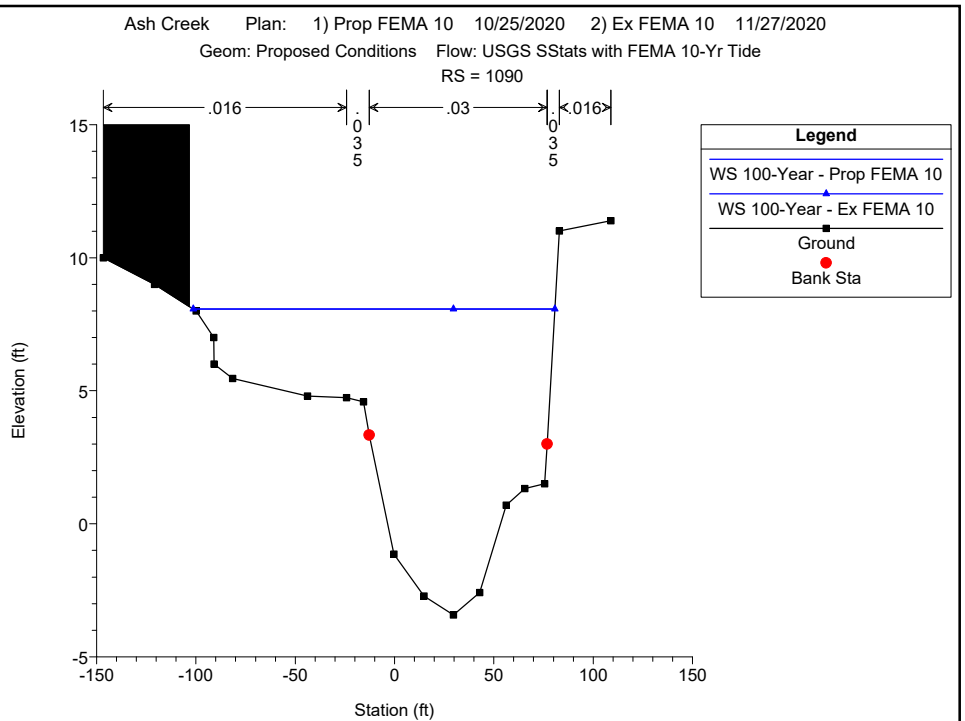
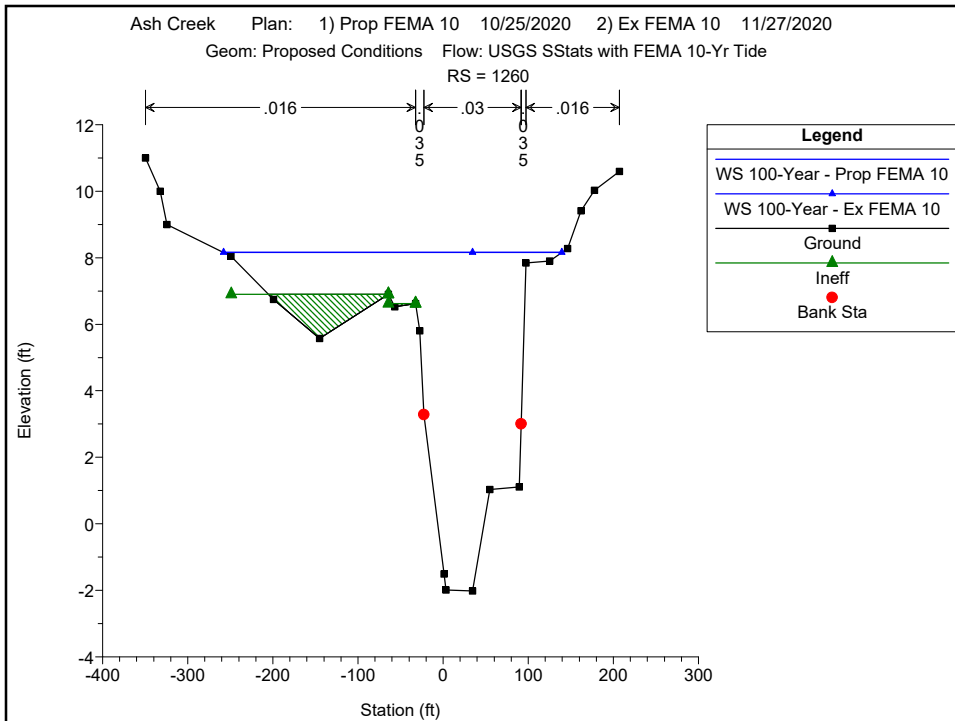

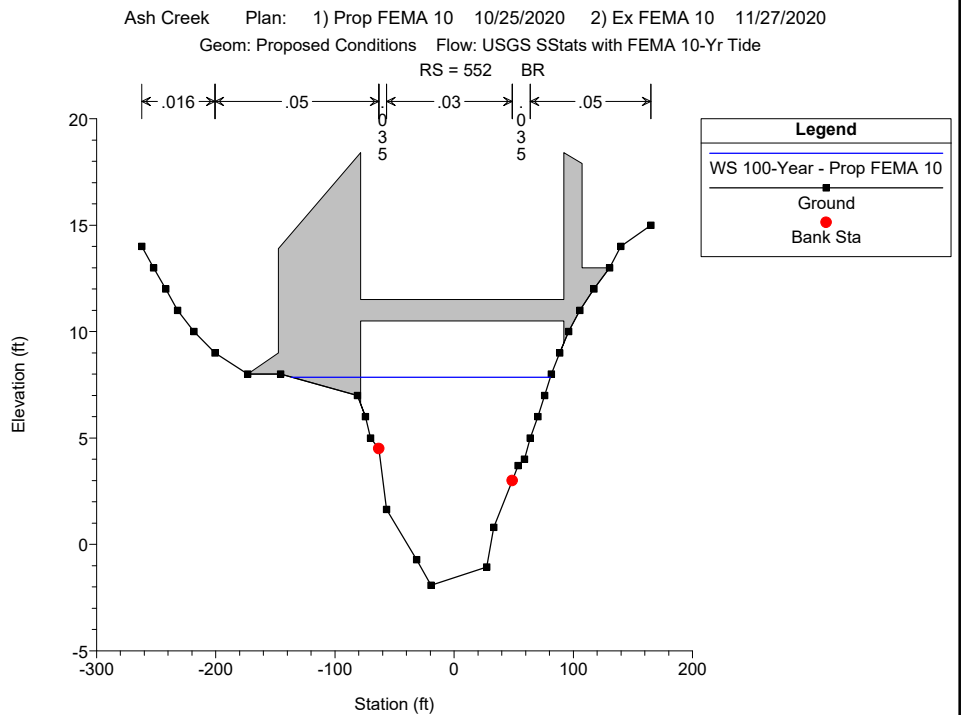
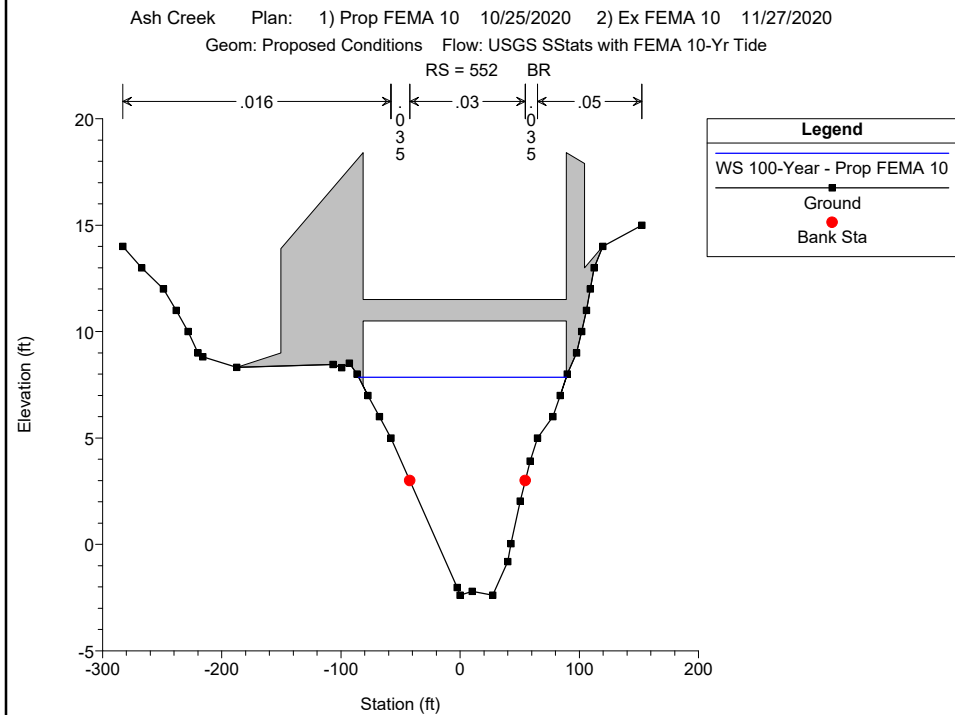
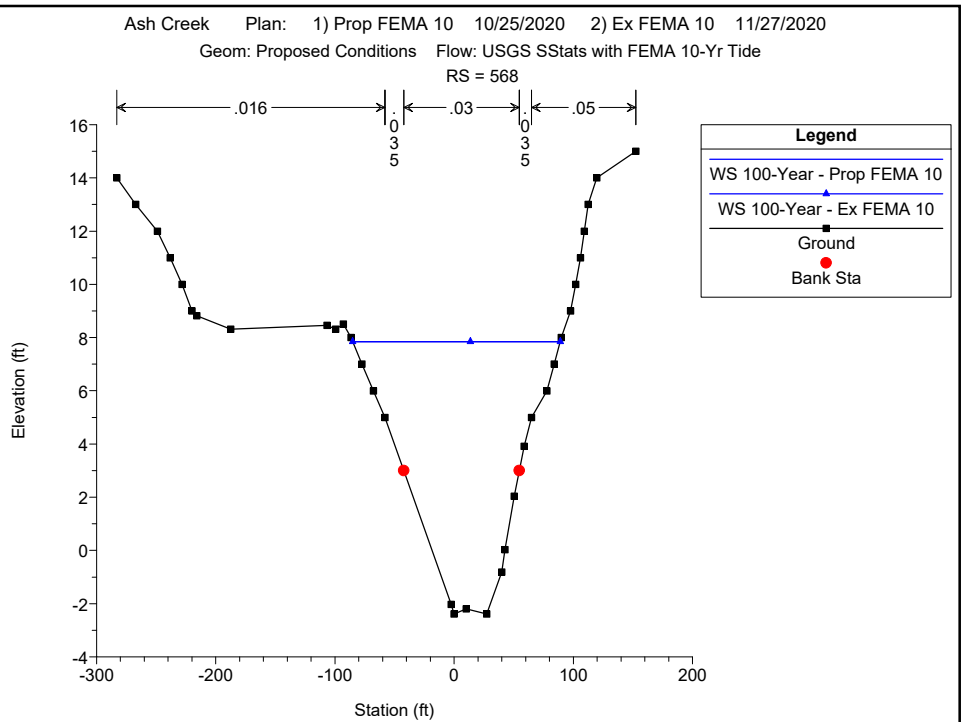
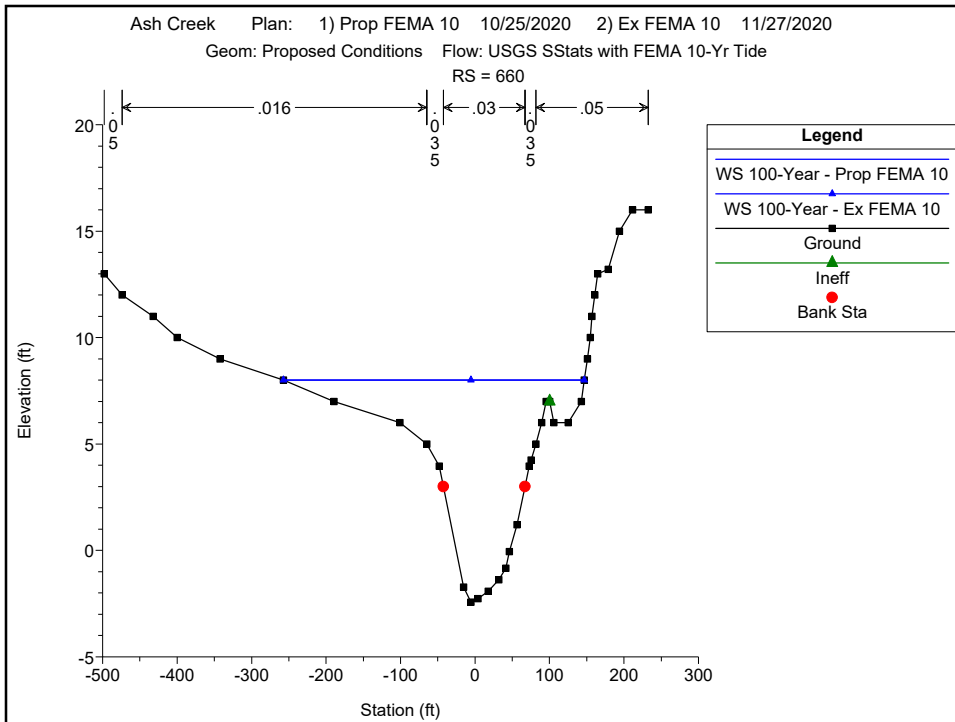

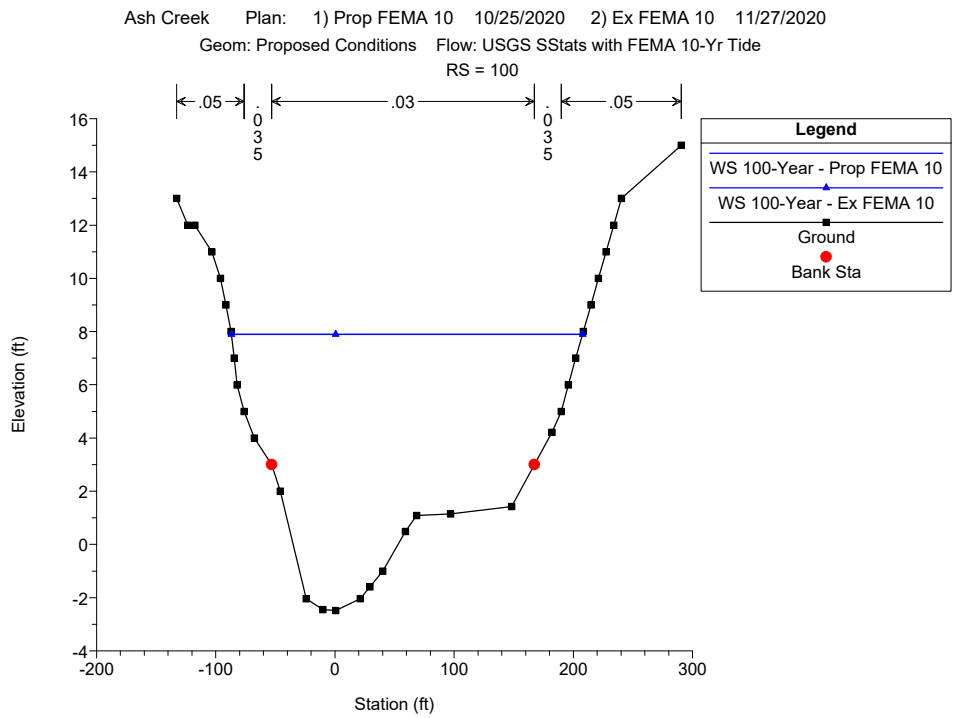
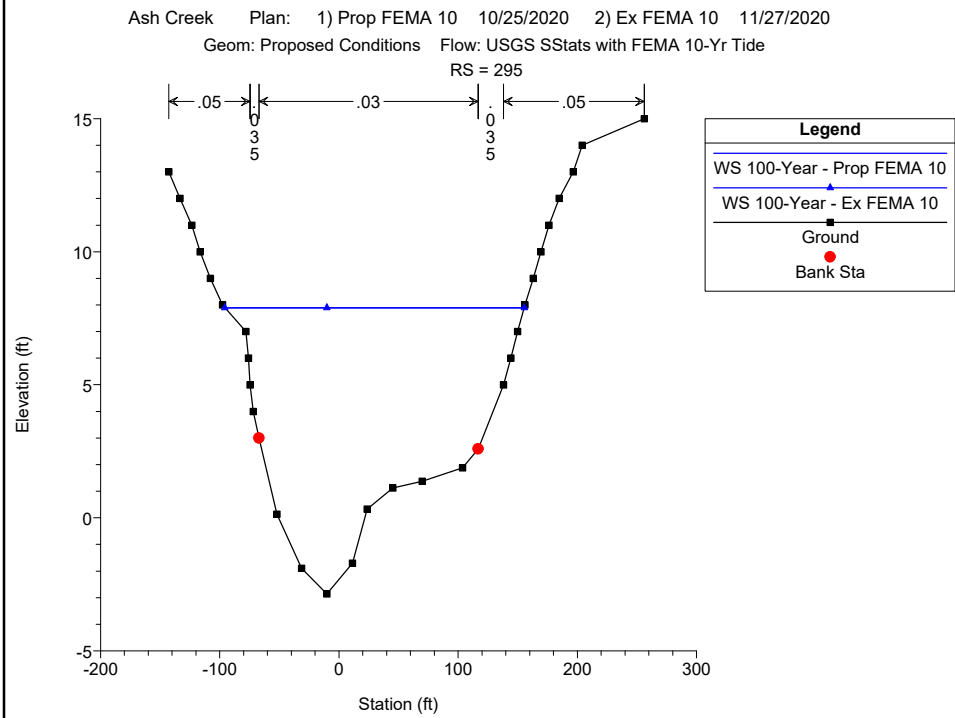
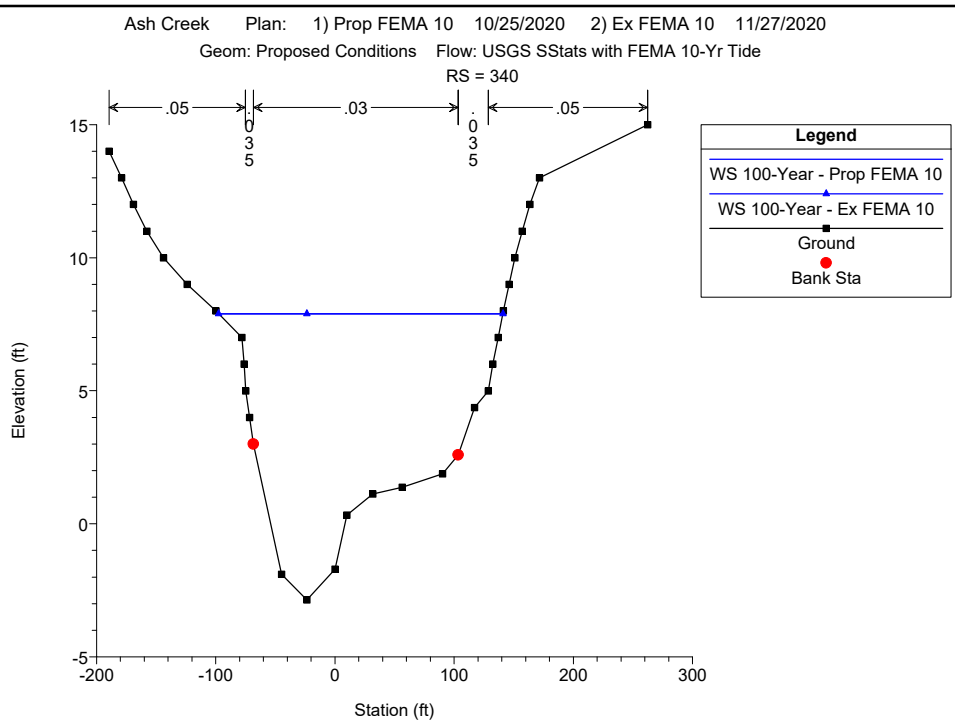
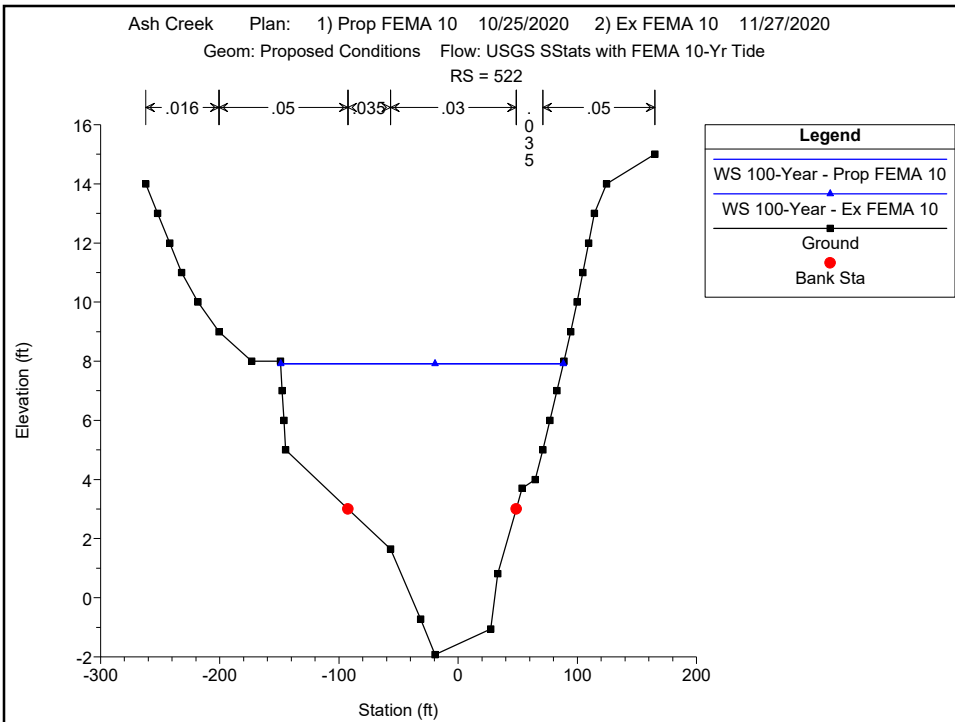

Ash Creek Plan: 1) Prop FEMA 10 10/25/2020 2) Ex FEMA 10 11/27/2020

Geom: Proposed Conditions Flow: USGS SStats with FEMA 10-Yr Tide

RS = 0

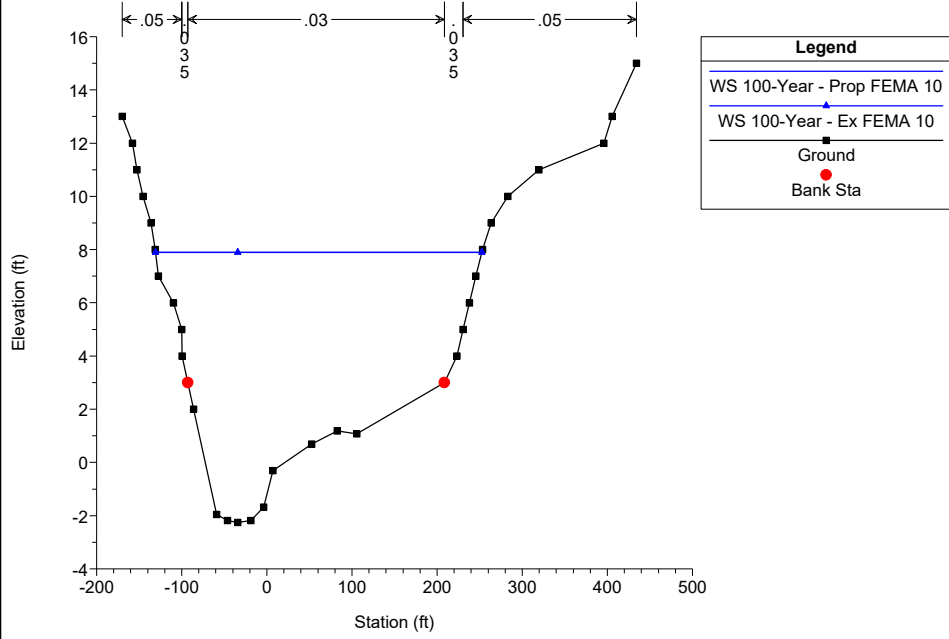

APPENDIX C – WATER SURFACE PROFILE ANALYSIS

- HEC-RAS 100-Year Water Surface Profile
- HEC-RAS Profile Output Table for All Storm Events

Ash Creek Plan: 1) Prop FEMA 10 10/25/2020 2) Ex FEMA 10 10/25/2020

Geom: Proposed Conditions Flow: USGS SStats with FEMA 10-Yr Tide

Ash Creek Reach

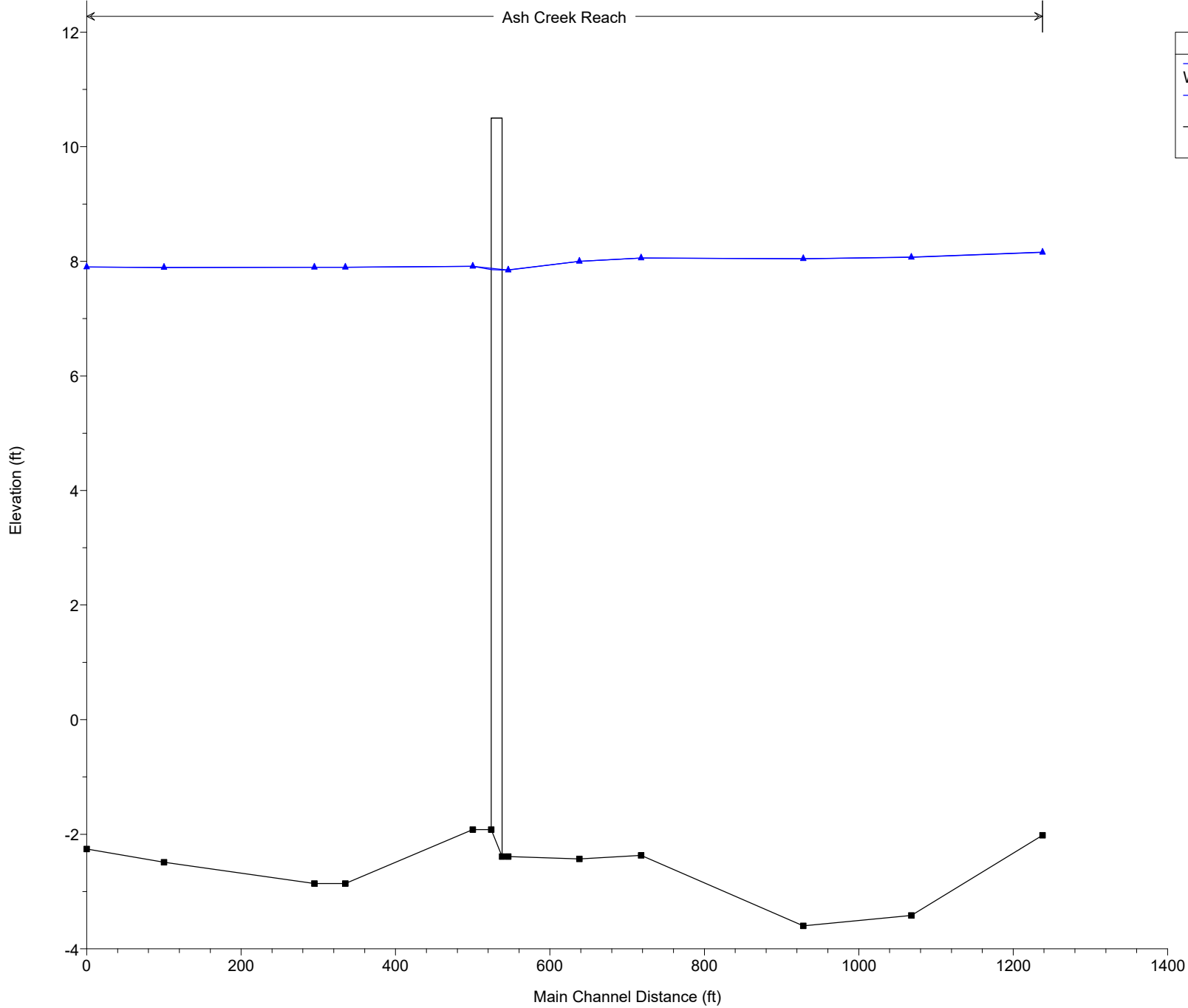

Legend

WS 100-Year - Prop FEMA 10

WS 100-Year - Ex FEMA 10

Ground

Reach	River Sta	Profile	Q Total (cfs)	Min Ch El (ft)	W.S. Elev (ft)	Crit W.S. (ft)	E.G. Elev (ft)	E.G. Slope (ft/ft)	Vel Chnl (ft/s)	Flow Area (sq ft)	Top Width (ft)	Froude # Chl
Reach	1260	2-Year	1100.00	-2.02	7.92		7.94	0.000029	1.07	1164.59	370.75	0.07
Reach	1260	10-Year	2060.00	-2.02	7.98		8.04	0.000099	1.97	1186.21	376.21	0.12
Reach	1260	25-Year	2580.00	-2.02	8.03		8.11	0.000151	2.44	1204.04	380.66	0.15
Reach	1260	50-Year	3060.00	-2.02	8.08		8.20	0.000204	2.86	1224.56	386.97	0.18
Reach	1260	100-Year	3630.00	-2.02	8.16		8.31	0.000273	3.32	1254.42	397.24	0.20
Reach	1260	500-Year	4300.00	-2.02	8.27		8.47	0.000356	3.83	1298.79	412.04	0.23
Reach	1090	2-Year	1100.00	-3.42	7.92		7.93	0.000029	1.13	1035.67	179.75	0.07
Reach	1090	10-Year	2060.00	-3.42	7.95		8.02	0.000100	2.10	1042.71	180.13	0.12
Reach	1090	25-Year	2580.00	-3.42	7.99		8.08	0.000155	2.62	1048.37	180.43	0.15
Reach	1090	50-Year	3060.00	-3.42	8.02		8.16	0.000214	3.08	1054.72	181.03	0.18
Reach	1090	100-Year	3630.00	-3.42	8.07		8.26	0.000294	3.63	1063.80	182.11	0.21
Reach	1090	500-Year	4300.00	-3.42	8.14		8.40	0.000399	4.25	1076.61	183.63	0.25
Reach	950	2-Year	1100.00	-3.60	7.91		7.93	0.000026	1.08	1086.83	193.87	0.06
Reach	950	10-Year	2060.00	-3.60	7.95		8.00	0.000091	2.02	1093.16	193.88	0.12
Reach	950	25-Year	2580.00	-3.60	7.97		8.06	0.000140	2.51	1098.27	193.89	0.15
Reach	950	50-Year	3060.00	-3.60	8.00		8.13	0.000194	2.96	1104.03	193.89	0.17
Reach	950	100-Year	3630.00	-3.60	8.04		8.22	0.000266	3.48	1112.29	193.91	0.20
Reach	950	500-Year	4300.00	-3.60	8.10		8.34	0.000362	4.08	1124.00	193.92	0.24
Reach	740	2-Year	1100.00	-2.37	7.91		7.92	0.000017	0.78	1569.73	350.64	0.05
Reach	740	10-Year	2060.00	-2.37	7.95		7.98	0.000059	1.45	1582.24	352.66	0.09
Reach	740	25-Year	2580.00	-2.37	7.98		8.02	0.000092	1.81	1592.42	354.30	0.12
Reach	740	50-Year	3060.00	-2.37	8.01		8.07	0.000126	2.13	1604.07	357.06	0.14
Reach	740	100-Year	3630.00	-2.37	8.06		8.15	0.000173	2.51	1620.93	361.73	0.16
Reach	740	500-Year	4300.00	-2.37	8.12		8.24	0.000234	2.93	1645.35	366.98	0.19
Reach	660	2-Year	1100.00	-2.43	7.91	0.36	7.92	0.000022	0.96	1407.49	397.32	0.06
Reach	660	10-Year	2060.00	-2.43	7.93	1.39	7.97	0.000076	1.79	1416.08	398.87	0.11
Reach	660	25-Year	2580.00	-2.43	7.95	1.83	8.01	0.000118	2.23	1423.13	400.14	0.13
Reach	660	50-Year	3060.00	-2.43	7.97	2.22	8.06	0.000164	2.64	1431.44	401.62	0.16
Reach	660	100-Year	3630.00	-2.43	8.00	2.63	8.13	0.000226	3.10	1443.72	403.81	0.19
Reach	660	500-Year	4300.00	-2.43	8.04	3.07	8.22	0.000308	3.64	1462.00	407.81	0.22
Reach	568	2-Year	1100.00	-2.39	7.90		7.92	0.000036	1.22	1000.56	174.90	0.07
Reach	568	10-Year	2060.00	-2.39	7.88		7.96	0.000126	2.29	998.57	174.73	0.14
Reach	568	25-Year	2580.00	-2.39	7.87		7.99	0.000199	2.87	996.92	174.59	0.17
Reach	568	50-Year	3060.00	-2.39	7.86		8.03	0.000282	3.41	995.06	174.42	0.21
Reach	568	100-Year	3630.00	-2.39	7.85		8.09	0.000399	4.06	992.36	174.19	0.25
Reach	568	500-Year	4300.00	-2.39	7.83		8.16	0.000566	4.82	988.41	173.84	0.29
Reach	522	2-Year	1100.00	-1.92	7.90		7.91	0.000023	0.91	1401.35	237.21	0.06
Reach	522	10-Year	2060.00	-1.92	7.90		7.94	0.000080	1.70	1401.99	237.23	0.11
Reach	522	25-Year	2580.00	-1.92	7.91		7.97	0.000126	2.13	1402.51	237.25	0.14
Reach	522	50-Year	3060.00	-1.92	7.91		8.00	0.000177	2.53	1403.10	237.27	0.16
Reach	522	100-Year	3630.00	-1.92	7.91		8.04	0.000248	3.00	1403.94	237.29	0.19
Reach	522	500-Year	4300.00	-1.92	7.92		8.09	0.000348	3.55	1405.07	237.33	0.23
Reach	340	2-Year	1100.00	-2.86	7.90		7.91	0.000017	0.79	1479.77	238.65	0.05
Reach	340	10-Year	2060.00	-2.86	7.90		7.93	0.000059	1.48	1479.54	238.62	0.09
Reach	340	25-Year	2580.00	-2.86	7.90		7.95	0.000092	1.85	1479.37	238.60	0.12
Reach	340	50-Year	3060.00	-2.86	7.90		7.97	0.000129	2.19	1479.18	238.58	0.14
Reach	340	100-Year	3630.00	-2.86	7.90		8.00	0.000182	2.60	1478.89	238.55	0.17
Reach	340	500-Year	4300.00	-2.86	7.89		8.04	0.000256	3.08	1478.45	238.50	0.20
Reach	295	2-Year	1100.00	-2.86	7.90		7.91	0.000014	0.73	1581.92	251.30	0.05
Reach	295	10-Year	2060.00	-2.86	7.90		7.93	0.000051	1.38	1581.80	251.28	0.09
Reach	295	25-Year	2580.00	-2.86	7.90		7.94	0.000079	1.72	1581.72	251.27	0.11
Reach	295	50-Year	3060.00	-2.86	7.90		7.96	0.000112	2.04	1581.63	251.27	0.13
Reach	295	100-Year	3630.00	-2.86	7.90		7.99	0.000157	2.43	1581.49	251.25	0.15
Reach	295	500-Year	4300.00	-2.86	7.90		8.02	0.000221	2.87	1581.27	251.23	0.18
Reach	100	2-Year	1100.00	-2.49	7.90		7.90	0.000010	0.60	1940.51	294.79	0.04
Reach	100	10-Year	2060.00	-2.49	7.90		7.92	0.000034	1.13	1940.09	294.78	0.07
Reach	100	25-Year	2580.00	-2.49	7.90		7.93	0.000053	1.42	1939.75	294.77	0.09
Reach	100	50-Year	3060.00	-2.49	7.90		7.94	0.000075	1.68	1939.36	294.76	0.11
Reach	100	100-Year	3630.00	-2.49	7.89		7.95	0.000106	1.99	1938.83	294.74	0.13
Reach	100	500-Year	4300.00	-2.49	7.89		7.97	0.000148	2.36	1938.03	294.72	0.15
Reach	0	2-Year	1100.00	-2.26	7.90	0.13	7.90	0.000006	0.48	2421.24	383.64	0.03
Reach	0	10-Year	2060.00	-2.26	7.90	1.08	7.91	0.000023	0.89	2421.24	383.64	0.06
Reach	0	25-Year	2580.00	-2.26	7.90	1.45	7.92	0.000036	1.12	2421.24	383.64	0.07
Reach	0	50-Year	3060.00	-2.26	7.90	1.70	7.93	0.000050	1.33	2421.24	383.64	0.09
Reach	0	100-Year	3630.00	-2.26	7.90	1.96	7.94	0.000071	1.57	2421.24	383.64	0.10
Reach	0	500-Year	4300.00	-2.26	7.90	2.23	7.95	0.000099	1.86	2421.24	383.64	0.12

Reach	River Sta	Profile	Q Total (cfs)	Min Ch El (ft)	W.S. Elev (ft)	Crit W.S. (ft)	E.G. Elev (ft)	E.G. Slope (ft/ft)	Vel Chnl (ft/s)	Flow Area (sq ft)	Top Width (ft)	Froude # Chl
Reach	1260	2-Year	1100.00	-2.02	7.92		7.94	0.000029	1.07	1164.64	370.77	0.07
Reach	1260	10-Year	2060.00	-2.02	7.98		8.04	0.000099	1.97	1186.39	376.26	0.12
Reach	1260	25-Year	2580.00	-2.02	8.03		8.11	0.000150	2.44	1204.43	380.75	0.15
Reach	1260	50-Year	3060.00	-2.02	8.08		8.20	0.000204	2.86	1225.03	387.13	0.18
Reach	1260	100-Year	3630.00	-2.02	8.16		8.31	0.000273	3.32	1255.13	397.49	0.20
Reach	1260	500-Year	4300.00	-2.02	8.27		8.47	0.000355	3.82	1299.89	412.40	0.23
Reach	1090	2-Year	1100.00	-3.42	7.92		7.93	0.000029	1.13	1035.69	179.75	0.07
Reach	1090	10-Year	2060.00	-3.42	7.96		8.02	0.000100	2.10	1042.79	180.14	0.12
Reach	1090	25-Year	2580.00	-3.42	7.99		8.09	0.000155	2.62	1048.56	180.44	0.15
Reach	1090	50-Year	3060.00	-3.42	8.02		8.16	0.000214	3.08	1054.94	181.05	0.18
Reach	1090	100-Year	3630.00	-3.42	8.07		8.26	0.000294	3.63	1064.12	182.15	0.21
Reach	1090	500-Year	4300.00	-3.42	8.14		8.40	0.000398	4.25	1077.10	183.69	0.25
Reach	950	2-Year	1100.00	-3.60	7.91		7.93	0.000026	1.08	1086.86	193.87	0.06
Reach	950	10-Year	2060.00	-3.60	7.95		8.00	0.000091	2.02	1093.25	193.88	0.12
Reach	950	25-Year	2580.00	-3.60	7.97		8.06	0.000140	2.51	1098.47	193.89	0.15
Reach	950	50-Year	3060.00	-3.60	8.00		8.13	0.000194	2.96	1104.26	193.89	0.17
Reach	950	100-Year	3630.00	-3.60	8.05		8.22	0.000266	3.48	1112.64	193.91	0.20
Reach	950	500-Year	4300.00	-3.60	8.11		8.34	0.000361	4.07	1124.54	193.93	0.24
Reach	740	2-Year	1100.00	-2.37	7.91		7.92	0.000017	0.78	1569.78	350.65	0.05
Reach	740	10-Year	2060.00	-2.37	7.95		7.98	0.000059	1.45	1582.41	352.69	0.09
Reach	740	25-Year	2580.00	-2.37	7.98		8.03	0.000092	1.81	1592.79	354.36	0.12
Reach	740	50-Year	3060.00	-2.37	8.01		8.08	0.000126	2.13	1604.51	357.18	0.14
Reach	740	100-Year	3630.00	-2.37	8.06		8.15	0.000173	2.51	1621.59	361.91	0.16
Reach	740	500-Year	4300.00	-2.37	8.13		8.25	0.000234	2.93	1646.38	367.00	0.19
Reach	660	2-Year	1100.00	-2.43	7.91	0.36	7.92	0.000022	0.96	1407.54	397.33	0.06
Reach	660	10-Year	2060.00	-2.43	7.93	1.39	7.97	0.000076	1.79	1416.27	398.91	0.11
Reach	660	25-Year	2580.00	-2.43	7.95	1.83	8.01	0.000118	2.23	1423.56	400.21	0.13
Reach	660	50-Year	3060.00	-2.43	7.97	2.22	8.06	0.000164	2.63	1431.95	401.71	0.16
Reach	660	100-Year	3630.00	-2.43	8.00	2.63	8.13	0.000226	3.10	1444.50	403.96	0.19
Reach	660	500-Year	4300.00	-2.43	8.05	3.07	8.22	0.000308	3.63	1463.21	408.08	0.22
Reach	568	2-Year	1100.00	-2.39	7.90	0.45	7.92	0.000036	1.22	1000.58	174.91	0.07
Reach	568	10-Year	2060.00	-2.39	7.88	1.59	7.96	0.000126	2.29	998.65	174.74	0.14
Reach	568	25-Year	2580.00	-2.39	7.88	2.11	7.99	0.000199	2.87	997.11	174.60	0.17
Reach	568	50-Year	3060.00	-2.39	7.87	2.53	8.03	0.000281	3.41	995.28	174.44	0.21
Reach	568	100-Year	3630.00	-2.39	7.85	2.98	8.09	0.000399	4.05	992.70	174.22	0.25
Reach	568	500-Year	4300.00	-2.39	7.83	3.42	8.16	0.000565	4.82	988.95	173.89	0.29
Reach	552		Bridge									
Reach	522	2-Year	1100.00	-1.92	7.90		7.91	0.000023	0.91	1401.35	237.21	0.06
Reach	522	10-Year	2060.00	-1.92	7.90		7.94	0.000080	1.70	1401.99	237.23	0.11
Reach	522	25-Year	2580.00	-1.92	7.91		7.97	0.000126	2.13	1402.51	237.25	0.14
Reach	522	50-Year	3060.00	-1.92	7.91		8.00	0.000177	2.53	1403.10	237.27	0.16
Reach	522	100-Year	3630.00	-1.92	7.91		8.04	0.000248	3.00	1403.94	237.29	0.19
Reach	522	500-Year	4300.00	-1.92	7.92		8.09	0.000348	3.55	1405.07	237.33	0.23
Reach	340	2-Year	1100.00	-2.86	7.90		7.91	0.000017	0.79	1479.77	238.65	0.05
Reach	340	10-Year	2060.00	-2.86	7.90		7.93	0.000059	1.48	1479.54	238.62	0.09
Reach	340	25-Year	2580.00	-2.86	7.90		7.95	0.000092	1.85	1479.37	238.60	0.12
Reach	340	50-Year	3060.00	-2.86	7.90		7.97	0.000129	2.19	1479.18	238.58	0.14
Reach	340	100-Year	3630.00	-2.86	7.90		8.00	0.000182	2.60	1478.89	238.55	0.17
Reach	340	500-Year	4300.00	-2.86	7.89		8.04	0.000256	3.08	1478.45	238.50	0.20
Reach	295	2-Year	1100.00	-2.86	7.90		7.91	0.000014	0.73	1581.92	251.30	0.05
Reach	295	10-Year	2060.00	-2.86	7.90		7.93	0.000051	1.38	1581.80	251.28	0.09
Reach	295	25-Year	2580.00	-2.86	7.90		7.94	0.000079	1.72	1581.72	251.27	0.11
Reach	295	50-Year	3060.00	-2.86	7.90		7.96	0.000112	2.04	1581.63	251.27	0.13
Reach	295	100-Year	3630.00	-2.86	7.90		7.99	0.000157	2.43	1581.49	251.25	0.15
Reach	295	500-Year	4300.00	-2.86	7.90		8.02	0.000221	2.87	1581.27	251.23	0.18
Reach	100	2-Year	1100.00	-2.49	7.90		7.90	0.000010	0.60	1940.51	294.79	0.04
Reach	100	10-Year	2060.00	-2.49	7.90		7.92	0.000034	1.13	1940.09	294.78	0.07
Reach	100	25-Year	2580.00	-2.49	7.90		7.93	0.000053	1.42	1939.75	294.77	0.09
Reach	100	50-Year	3060.00	-2.49	7.90		7.94	0.000075	1.68	1939.36	294.76	0.11
Reach	100	100-Year	3630.00	-2.49	7.89		7.95	0.000106	1.99	1938.83	294.74	0.13
Reach	100	500-Year	4300.00	-2.49	7.89		7.97	0.000148	2.36	1938.03	294.72	0.15
Reach	0	2-Year	1100.00	-2.26	7.90	0.13	7.90	0.000006	0.48	2421.24	383.64	0.03
Reach	0	10-Year	2060.00	-2.26	7.90	1.17	7.91	0.000023	0.89	2421.24	383.64	0.06
Reach	0	25-Year	2580.00	-2.26	7.90	1.47	7.92	0.000036	1.12	2421.24	383.64	0.07
Reach	0	50-Year	3060.00	-2.26	7.90	1.70	7.93	0.000050	1.33	2421.24	383.64	0.09

HEC-RAS Plan: Prop FEMA 10 River: Ash Creek Reach: Reach (Continued)

Reach	River Sta	Profile	Q Total (cfs)	Min Ch El (ft)	W.S. Elev (ft)	Crit W.S. (ft)	E.G. Elev (ft)	E.G. Slope (ft/ft)	Vel Chnl (ft/s)	Flow Area (sq ft)	Top Width (ft)	Froude # Chl
Reach	0	100-Year	3630.00	-2.26	7.90	1.96	7.94	0.000071	1.57	2421.24	383.64	0.10
Reach	0	500-Year	4300.00	-2.26	7.90	2.23	7.95	0.000099	1.86	2421.24	383.64	0.12

APPENDIX D – INUNDATION MAPS

NOTE: ALL STORM EVENTS USE THE 10-YEAR FEMA FLOOD ELEVATION AS THE DOWNSTREAM BOUNDARY. THE CALCULATED PROPOSED WATER SURFACE ELEVATIONS ARE WITHIN ONE TENTH OF THE EXISTING WATER SURFACE ELEVATIONS THROUGHOUT THE PROJECT AREA. DUE TO THE NEGLIGIBLE DIFFERENCE IN ELEVATION, THE PLANS PORTRAY NO CHANGE.

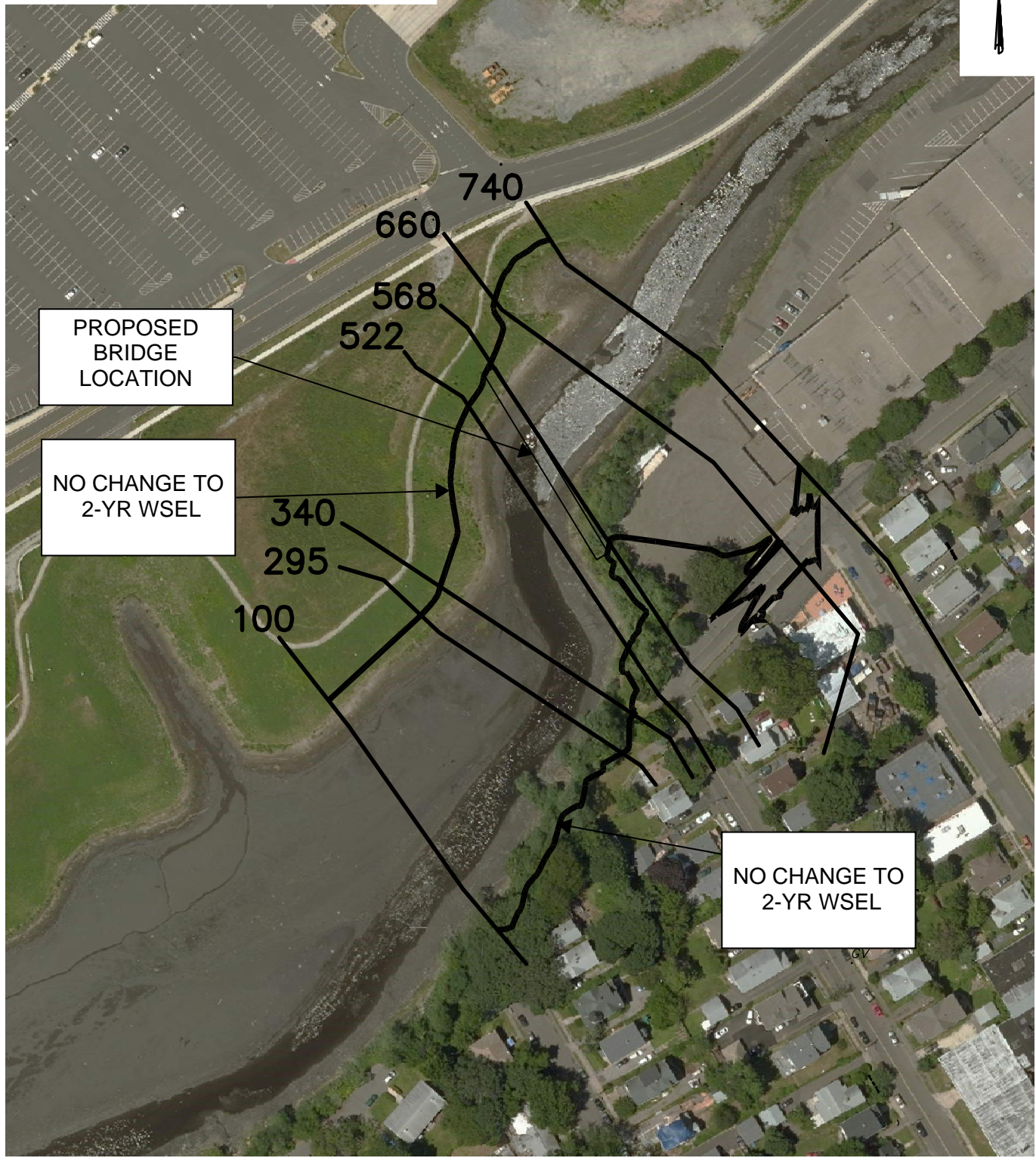

PEDESTRIAN BRIDGE
OVER
ASH CREEK
BRIDGEPORT AND FAIRFIELD, CT

2-YEAR
INUNDATION MAP

FIGURE NO.: 1

SCALE: 1" = 150'

NOTE: ALL STORM EVENTS USE THE 10-YEAR FEMA FLOOD ELEVATION AS THE DOWNSTREAM BOUNDARY. THE CALCULATED PROPOSED WATER SURFACE ELEVATIONS ARE WITHIN ONE TENTH OF THE EXISTING WATER SURFACE ELEVATIONS THROUGHOUT THE PROJECT AREA. DUE TO THE NEGLIGIBLE DIFFERENCE IN ELEVATION, THE PLANS PORTRAY NO CHANGE.

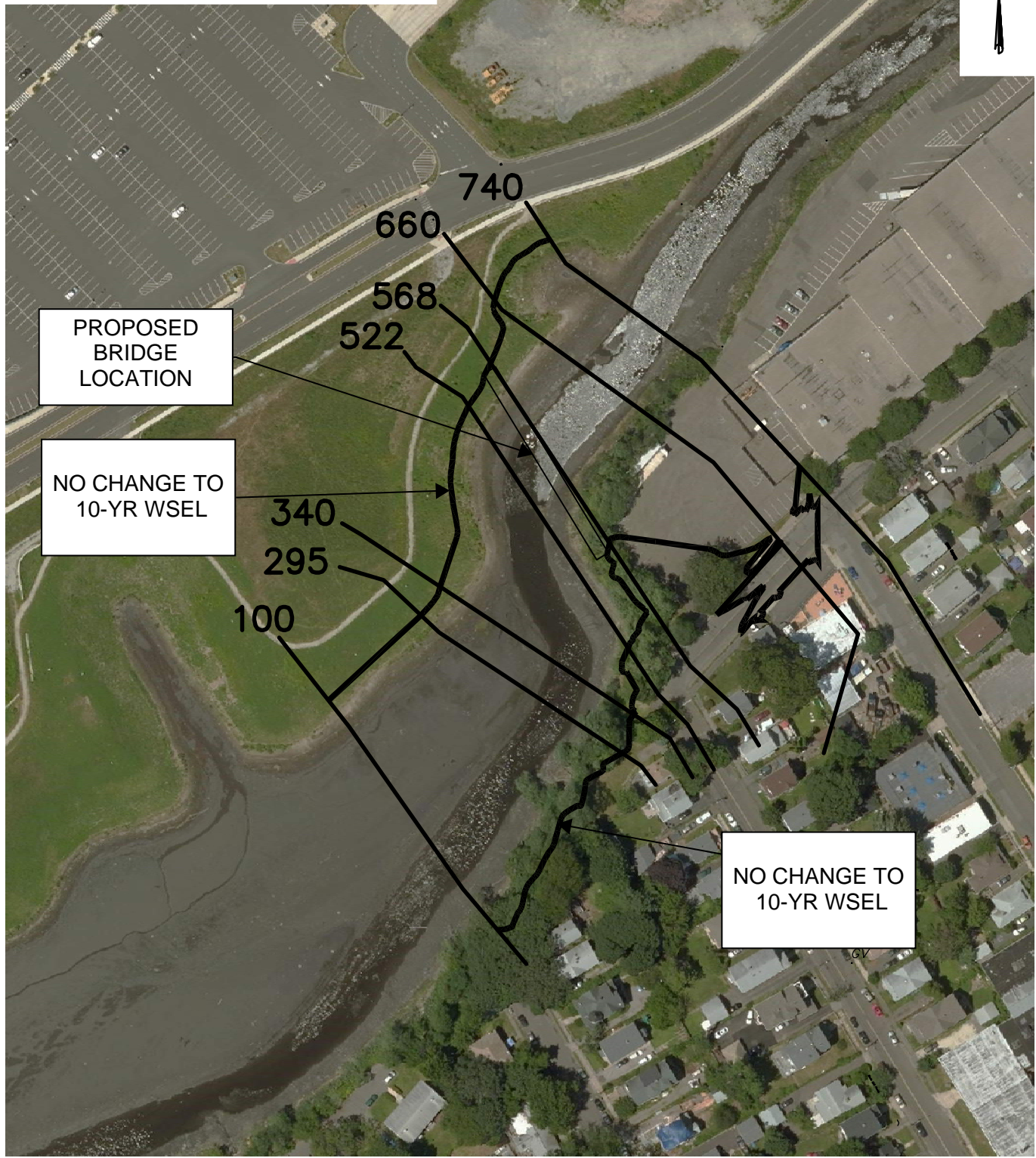

PEDESTRIAN BRIDGE
OVER
ASH CREEK
BRIDGEPORT AND FAIRFIELD, CT

10-YEAR
INUNDATION MAP

FIGURE NO.: 2

SCALE: 1" = 150'

NOTE: ALL STORM EVENTS USE THE 10-YEAR FEMA FLOOD ELEVATION AS THE DOWNSTREAM BOUNDARY. THE CALCULATED PROPOSED WATER SURFACE ELEVATIONS ARE WITHIN ONE TENTH OF THE EXISTING WATER SURFACE ELEVATIONS THROUGHOUT THE PROJECT AREA. DUE TO THE NEGLIGIBLE DIFFERENCE IN ELEVATION, THE PLANS PORTRAY NO CHANGE.

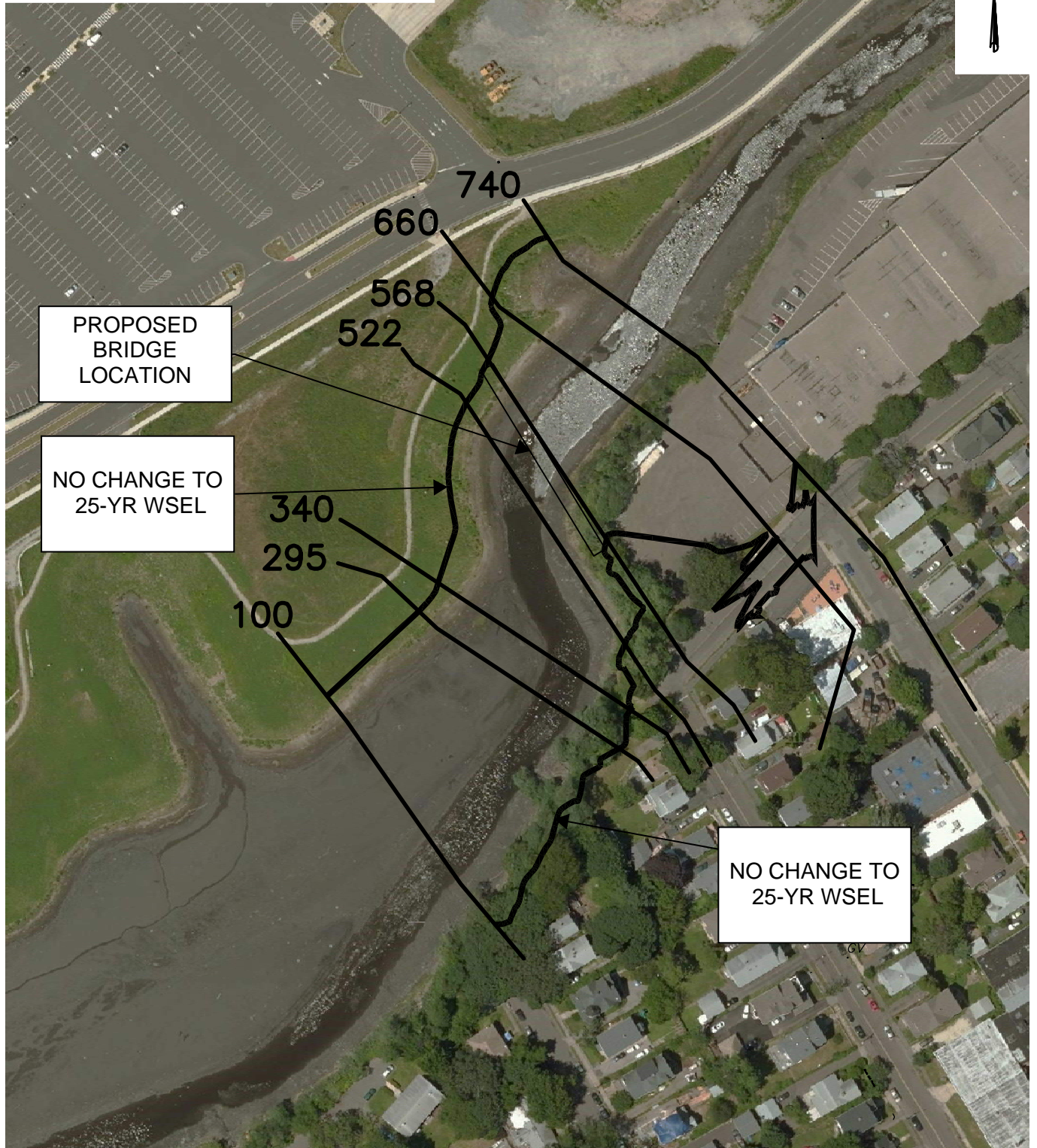

PEDESTRIAN BRIDGE
OVER
ASH CREEK
BRIDGEPORT AND FAIRFIELD, CT

25-YEAR
INUNDATION MAP

FIGURE NO.: 3

SCALE: 1" = 150'

NOTE: ALL STORM EVENTS USE THE 10-YEAR FEMA FLOOD ELEVATION AS THE DOWNSTREAM BOUNDARY. THE CALCULATED PROPOSED WATER SURFACE ELEVATIONS ARE WITHIN ONE TENTH OF THE EXISTING WATER SURFACE ELEVATIONS THROUGHOUT THE PROJECT AREA. DUE TO THE NEGLIGIBLE DIFFERENCE IN ELEVATION, THE PLANS PORTRAY NO CHANGE.

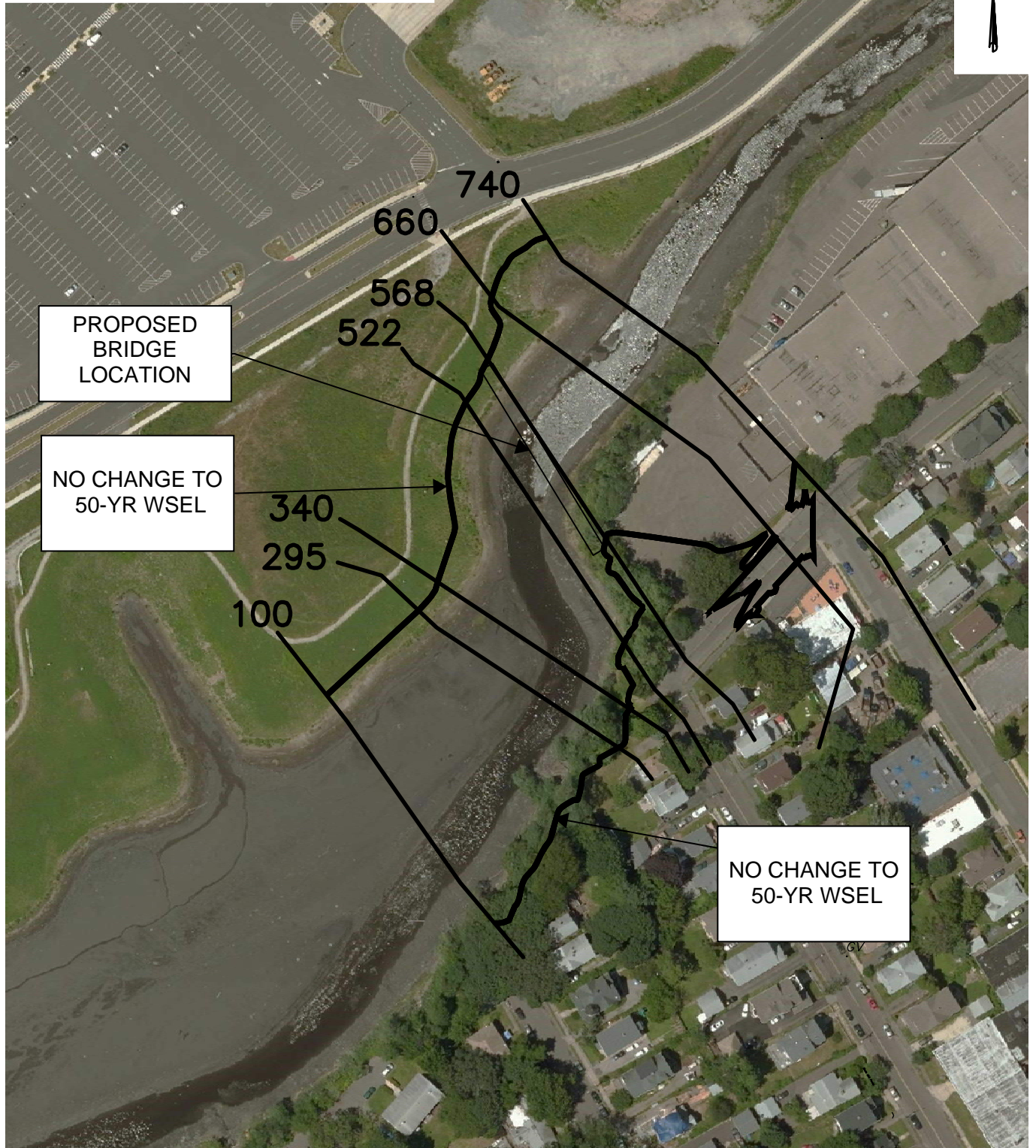

PEDESTRIAN BRIDGE
OVER
ASH CREEK
BRIDGEPORT AND FAIRFIELD, CT

50-YEAR
INUNDATION MAP

FIGURE NO.: 4

SCALE: 1" = 150'

NOTE: ALL STORM EVENTS USE THE 10-YEAR FEMA FLOOD ELEVATION AS THE DOWNSTREAM BOUNDARY. THE CALCULATED PROPOSED WATER SURFACE ELEVATIONS ARE WITHIN ONE TENTH OF THE EXISTING WATER SURFACE ELEVATIONS THROUGHOUT THE PROJECT AREA. DUE TO THE NEGLIGIBLE DIFFERENCE IN ELEVATION, THE PLANS PORTRAY NO CHANGE.

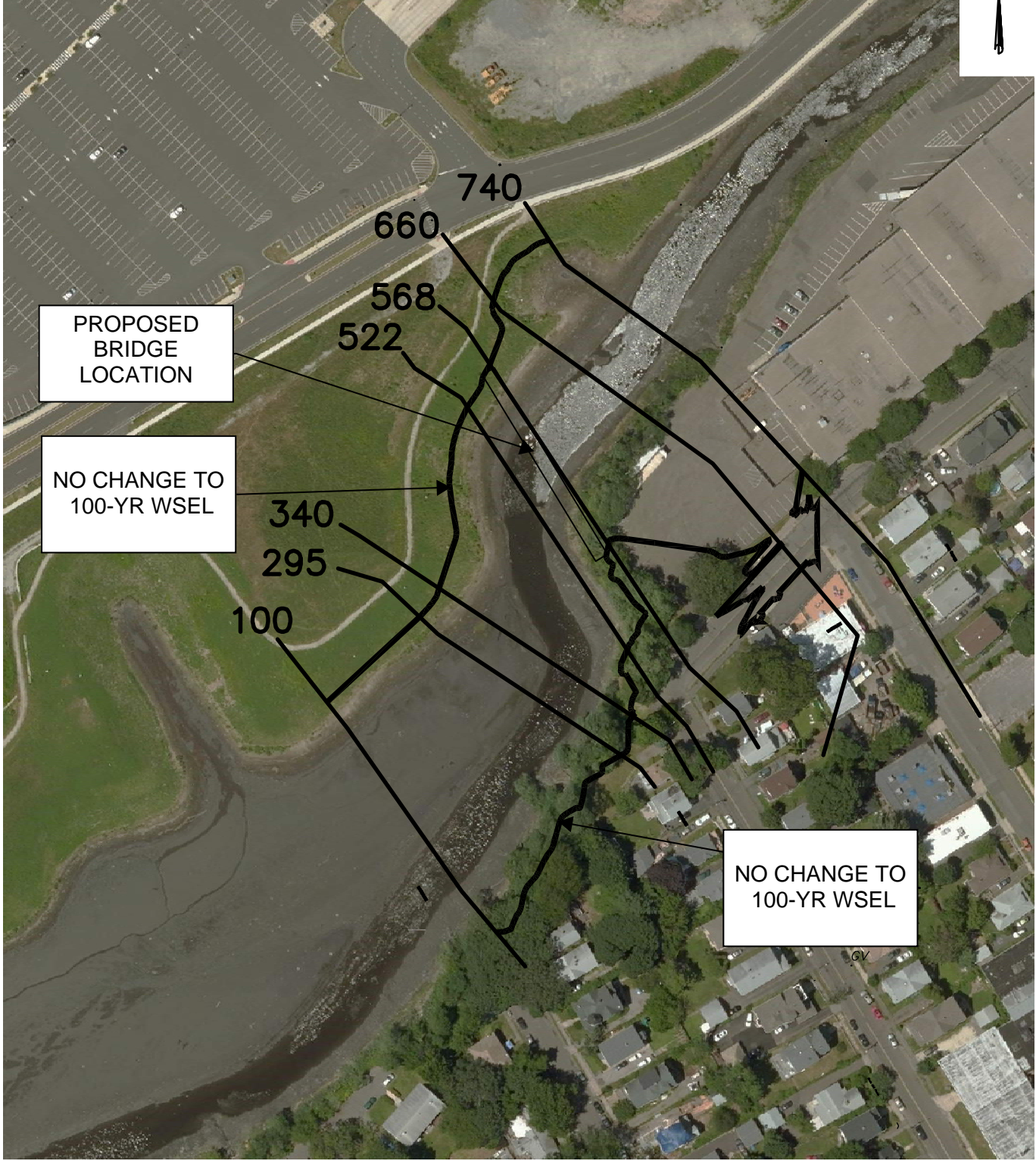

PEDESTRIAN BRIDGE
OVER
ASH CREEK
BRIDGEPORT AND FAIRFIELD, CT

100-YEAR
INUNDATION MAP

FIGURE NO.: 5

SCALE: 1" = 150'